



Motor 2-polig Drehzahl 3500 min ⁻¹								Motor 4-polig Drehzahl 1750 min ⁻¹						
max. Förderdruck	Förderstrom bei Viskosität		Leistungsbedarf bei Viskosität		Motor		Gewicht	Förderstrom bei Viskosität		Leistungsbedarf bei Viskosität		Motor		Gewicht
	1 mm ² /s	20 mm ² /s	1 mm ² /s	20 mm ² /s	IE3	NEMA		IE3	1 mm ² /s	20 mm ² /s	1 mm ² /s	20 mm ² /s	IE3	
Type / bar	l/min	l/min	kW	kW	kW	kW	kg	l/min	l/min	kW	kW	kW	kW	kg
TFS574/	Q _{Th} ¹⁾ 291,6		-	-	-	-	-	Q _{Th} ¹⁾ 145,8		-	-	-	-	-
10	280	285	6,2	7,0	8,6	11,0	123	134	139	2,9	3,4	4,55	5,5	99
20	276	283	11,0	12,1	17,3	15,0	151	130	137	5,4	6,0	8,6	7,5	130
30	272	281	15,9	17,2	21,3	22,0	161	126	135	7,8	8,5	12,6	11,0	150
40	269	279	20,7	22,2	25,3	30,0	189	123	134	10,2	11,1	12,6	15,0	150
50	266	278	25,6	27,3	33,5	30,0	243	120	132	12,6	13,7	17,3	15,0	167
60	262	276	30,5	32,4	33,5	37,0	243	117	130	15,1	16,2	17,3	18,5	167
70	260	274	35,3	37,5	41,5	45,0	264	114	129	17,5	18,8	21,3	22,0	201
80	257	273	40,2	42,6	51,0	45,0	385	111	127	19,9	21,4	25,3	22,0	209
90	254	271	45,0	47,7	51,0	55,0	385	108	126	22,3	23,9	25,3	30,0	209
100	252	270	49,9	52,7	62,0	55,0	460	105	124	24,8	26,5	34,5	30,0	259
110	249	269	54,7	57,8	62,0	75,0	460	-	123	-	29,1	34,5	30,0	259
120	247	267	59,6	62,9	84,0	75,0	585	-	122	-	31,6	34,5	37,0	259
TFS5100/	Q _{Th} ¹⁾ 394,1		-	-	-	-	-	Q _{Th} ¹⁾ 197		-	-	-	-	-
10	378	386	7,9	8,7	12,6	11,0	142	181	189	3,8	4,3	6,3	5,5	130
20	374	383	14,4	15,6	21,3	18,5	161	177	186	7,1	7,8	8,6	11,0	130
30	370	381	21,0	22,6	25,3	30,0	189	173	184	10,4	11,3	12,6	15,0	150
40	366	379	27,6	29,5	33,5	37,0	243	169	182	13,6	14,8	17,3	18,5	167
50	362	377	34,1	36,4	41,5	45,0	264	165	180	16,9	18,3	21,3	22,0	201
60	358	375	40,7	43,4	51,0	55,0	385	161	178	20,2	21,8	25,3	22,0	209
70	355	373	47,3	50,3	62,0	55,0	460	158	176	23,5	25,3	34,5	30,0	259
80	351	371	53,8	57,3	62,0	75,0	460	154	174	26,8	28,8	34,5	30,0	259
90	348	369	60,4	64,2	84,0	75,0	585	150	172	30,1	32,3	34,5	37,0	259
100	345	368	67,0	71,1	84,0	75,0	585	147	171	33,3	35,8	42,5	37,0	355
110	342	366	73,5	78,1	84,0	90,0	585	-	169	-	39,3	42,5	45,0	355
120	338	365	80,1	85,0	101,0	90,0	665	-	168	-	42,8	52,0	45,0	390

¹⁾ Q_{th}: Theoretischer Förderstrom
 Viskosität > 20 mm²/s erhöhter Leistungsbedarf.

Kennlinien und Abmessungen

TFS5, FFS5

60 Hz

Blechausschnitte

TFS5

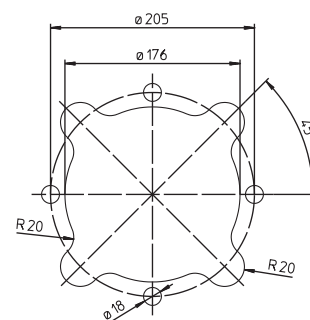

Alle Kanten gratfrei!
Allgemeintoleranzen
ISO 2768-m

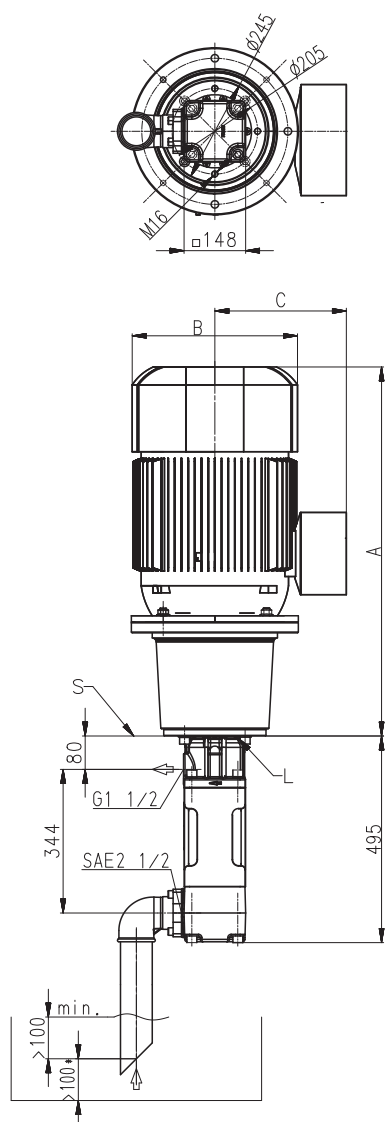

L = Leckagebohrung
S = Auflage, siehe
Blechausschnitte

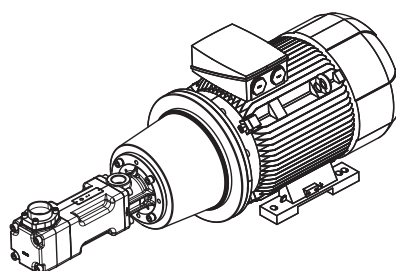

< 45kW

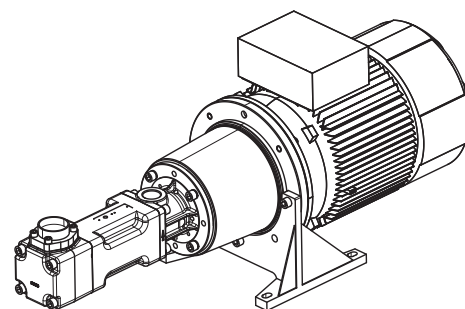

≥ 45kW

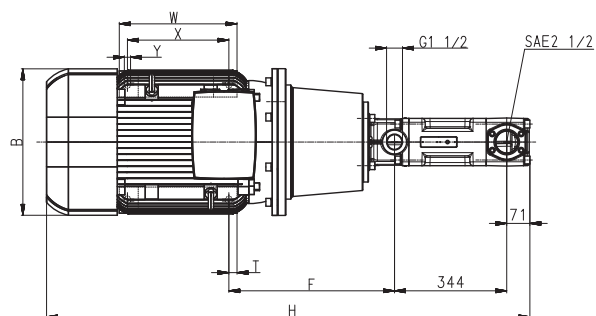
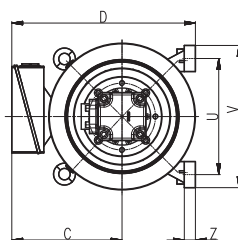

Leistung 2-polig kW	Leistung 4-polig kW	A	B	C	D	F	H	T	U	V	W	X	Y	Z
		mm	mm	mm	mm	mm	mm	mm	mm	mm	mm	mm	mm	mm
–	4,55	581	222	177	332	228	1076	22,5	215	250	230	185	14	15
8,6	5,5 / 6,3	672	262	202	387	222	1167	22,5	265	300	270	225	14	18
–	7,5 / 8,6	681	262	202	387	222	1176	22,5	265	300	270	225	14	18
11,0 / 12,6 / 15,0 / 17,3	11,0 / 12,6	767	314	237	472	237	1262	20	300	350	305	265	18	18
18,5 / 21,3	15,0 / 17,3	827	314	237	472	237	1322	20	300	350	305	265	18	18
–	18,5 / 21,3	831	356	286	521	237	1326	20	300	350	305	265	18	18
22,0 / 25,3	–	827	356	286	521	237	1322	20	300	350	305	265	18	18
–	22,0 / 25,3	861	356	286	521	237	1356	20	300	350	305	265	18	18
30,0 / 33,5	–	884	396	315	575	227	1379	25	350	400	350	300	18	20
37,0 / 41,5	30,0 / 34,5	909	396	315	575	227	1404	25	350	400	350	300	18	20
–	37,0 / 42,5	929	449	338	633	223	1422	25	400	450	385	335	18	20
45,0 / 51,0	45,0 / 52,0	987	449	338	563	508	1482	25	356	436	361	311	19	34
55,0 / 62,0	–	1059	497	410	660	560	1554	30	406	490	409	349	24	40
75,0 / 84,0	–	1132	551	433	713	582	1627	55,5	457	540	479	368	24	40
90,0 / 101,0	–	1243	551	433	713	582	1738	30	457	540	479	419	24	40



Motor 2-polig Drehzahl 3500 min ⁻¹								Motor 4-polig Drehzahl 1750 min ⁻¹						
max. Förderdruck	Förderstrom bei Viskosität		Leistungsbedarf bei Viskosität		Motor		Gewicht	Förderstrom bei Viskosität		Leistungsbedarf bei Viskosität		Motor		Gewicht
	1 mm ² /s	20 mm ² /s	1 mm ² /s	20 mm ² /s	IE3	NEMA		IE3	1 mm ² /s	20 mm ² /s	1 mm ² /s	20 mm ² /s	IE3	
Type / bar	l/min	l/min	kW	kW	kW	kW	kg	l/min	l/min	kW	kW	kW	kW	kg
TFS5120/	Q _{Th} ¹⁾ 472,9		-	-	-	-	-	Q _{Th} ¹⁾ 236,4		-	-	-	-	-
10	453	463	9,2	10,0	12,6	15,0	142	217	227	4,4	5,0	6,3	7,5	130
20	447	460	17,1	18,4	21,3	22,0	161	211	223	8,4	9,2	12,6	11,0	150
30	442	457	24,9	26,7	33,5	30,0	243	205	220	12,3	13,4	17,3	15,0	167
40	436	454	32,8	35,1	41,5	37,0	264	200	218	16,3	17,6	21,3	18,5	201
50	431	452	40,7	43,5	51,0	55,0	385	195	215	20,2	21,8	25,3	22,0	209
60	426	449	48,6	51,9	62,0	55,0	460	190	213	24,1	26,1	34,5	30,0	259
70	421	447	56,5	60,2	62,0	75,0	460	185	210	28,1	30,3	34,5	37,0	259
80	417	445	64,3	68,6	84,0	75,0	585	180	208	32,0	34,5	42,5	37,0	355
90	412	443	72,2	77,0	84,0	90,0	585	175	206	36,0	38,7	42,5	45,0	355
100	408	441	80,1	85,4	101,0	90,0	665	170	205	39,9	42,9	52,0	45,0	390
110	403	440	88,0	93,7	101,0	110,0	665	-	203	-	47,1	52,0	55,0	390
120	399	438	95,8	102,1	123,0	110,0	825	-	202	-	51,3	63,0	55,0	495
TFS5130/	Q _{Th} ¹⁾ 512,3		-	-	-	-	-	Q _{Th} ¹⁾ 256,1		-	-	-	-	-
10	491	500	9,8	11,7	17,3	15,0	151	235	243	4,8	5,4	6,3	7,5	130
20	484	495	18,4	20,3	25,3	30,0	189	228	239	9,0	9,8	12,6	11,0	150
30	477	490	26,9	29,0	33,5	37,0	243	221	234	13,3	14,2	17,3	15,0	167
40	471	486	35,5	37,6	41,5	45,0	264	215	230	17,6	18,6	21,3	22,0	201
50	465	482	44,0	46,2	51,0	55,0	385	209	225	21,8	23,0	25,3	30,0	209
60	459	477	52,5	54,8	62,0	75,0	460	203	221	26,1	27,3	34,5	30,0	259
70	454	474	61,1	63,5	84,0	75,0	585	198	217	30,4	31,7	34,5	37,0	259
80	449	470	69,6	72,1	84,0	75,0	585	193	214	34,7	36,1	42,5	37,0	355
90	444	466	78,1	80,7	84,0	90,0	585	187	210	38,9	40,5	42,5	45,0	355
100	440	463	86,7	89,3	101,0	90,0	665	182	207	43,2	44,9	52,0	55,0	390
110	-	460	-	98,0	123,0	110,0	825	-	204	-	49,3	52,0	55,0	390
120	-	457	-	106,6	123,0	110,0	825	-	201	-	53,7	63,0	55,0	495

¹⁾ Q_{th}: Theoretischer Förderstrom
 Viskosität > 20 mm²/s erhöhter Leistungsbedarf.

Kennlinien und Abmessungen

TFS5, FFS5

60 Hz

Blechausschnitte

TFS5

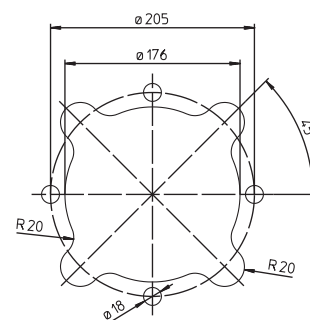

Alle Kanten gratfrei
Allgemeintoleranzen
ISO 2768-m

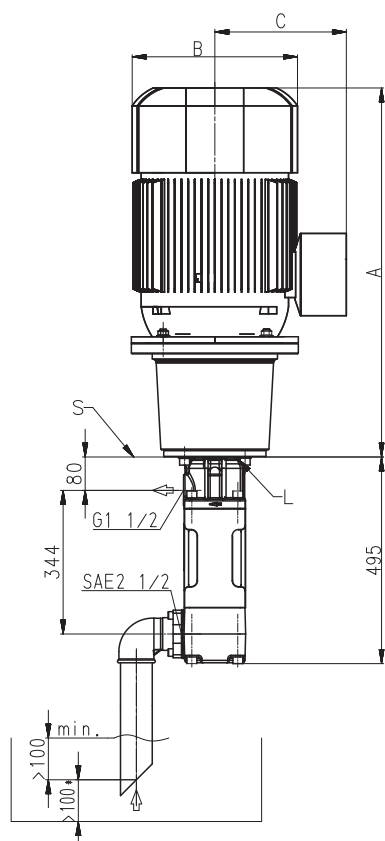
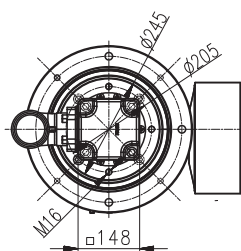

L = Leckagebohrung
S = Auflage, siehe
Blechausschnitte

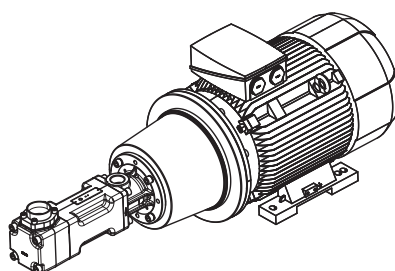

< 45kW

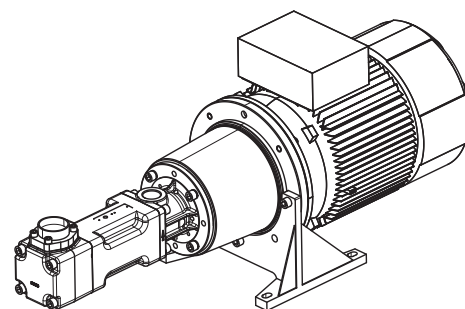

≥ 45kW

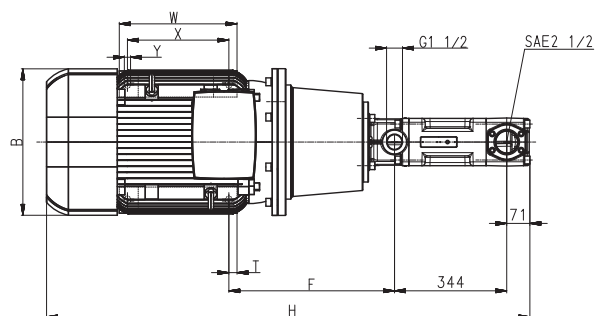
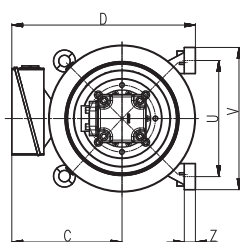

Leistung 2-polig kW	Leistung 4-polig kW	A	B	C	D	F	H	T	U	V	W	X	Y	Z
		mm	mm	mm	mm	mm	mm	mm	mm	mm	mm	mm	mm	mm
–	6,3	672	262	202	387	222	1167	22,5	265	300	270	225	14	18
–	7,5	681	262	202	387	222	1176	22,5	265	300	270	225	14	18
12,6 / 15,0 / 17,3	11,0 / 12,6	767	314	237	472	237	1262	20	300	350	305	265	18	18
21,3	15,0 / 17,3	827	314	237	472	237	1322	20	300	350	305	265	18	18
–	18,5 / 21,3	831	356	286	521	237	1326	20	300	350	305	265	18	18
22,0 / 25,3	–	827	356	286	521	237	1322	20	300	350	305	265	18	18
–	22,0 / 25,3	861	356	286	521	237	1356	20	300	350	305	265	18	18
30,0 / 33,5	–	884	396	315	575	227	1379	25	350	400	350	300	18	20
37,0 / 41,5	30,0 / 34,5	909	396	315	575	227	1404	25	350	400	350	300	18	20
–	37,0 / 42,5	929	449	338	633	223	1422	25	400	450	385	335	18	20
45,0 / 51,0	45,0 / 52,0	987	449	338	563	508	1482	25	356	436	361	311	19	34
55,0 / 62,0	55,0 / 63,0	1059	497	410	660	560	1554	30	406	490	409	349	24	40
75,0 / 84,0	–	1132	551	433	713	582	1627	55,5	457	540	479	368	24	40
90,0 / 101,0	–	1243	551	433	713	582	1738	30	457	540	479	419	24	40
110,0 / 123,0	–	1239	616	515	830	623	1734	35	508	610	527	406	28	50