

Immersion Pumps

(S)TH2

Closed impellers



STH203...231

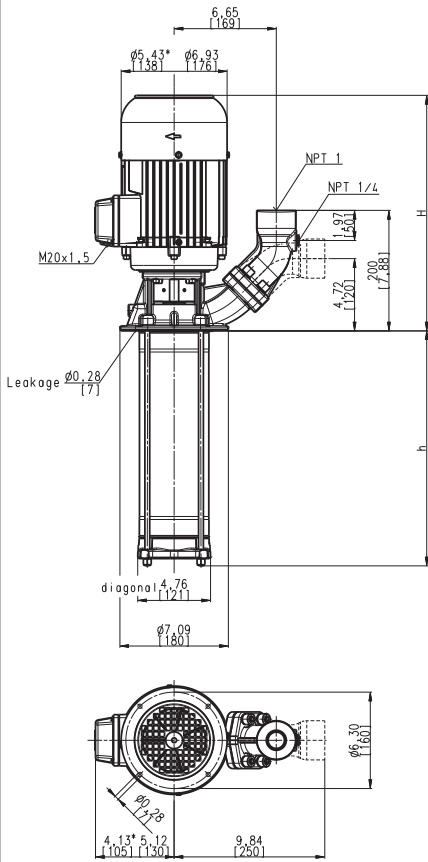

TH203...231

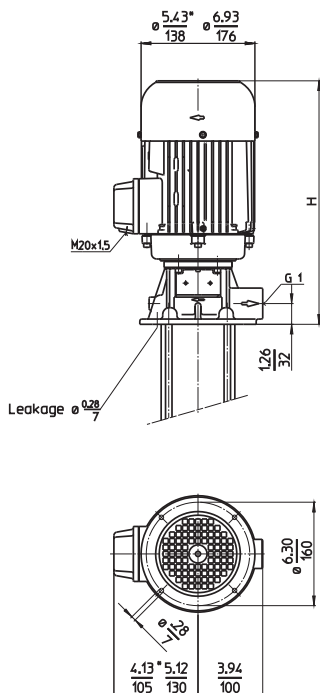

Type	Flow at head	Height	Depth of im- mersion		Weight		Power HP kW	Voltage 3~ V	Fre- quen- cy Hz	Current AMPS	Speed RPM
	GPM /Feet	H inch	h inch	h mm	Lbs	kg					
(S)TH203S190	5/80	11.5	7.48	190	32.9	14.9	0.75	208-230	60	2.38	3405
(S)TH204S190	5/110				33.1	15.0	0.55	460	60	1.14	3405
(S)TH205S190	5/130				33.3	15.1					
(S)TH206S190	5/165				33.5	15.2					
(S)TH207S290	5/190	13.1	11.42	290	41.0	18.6	1	208-230	60	3.02	3425
(S)TH208S290	5/220				41.2	18.7	0.725	460	60	1.46	3425
(S)TH209S290	5/240	13.1	11.42	290	42.3	19.2	1.15	230	60	3.70	3440
							0.86	460	60	1.85	3440
(S)TH210S290	5/270	13.1	11.42	290	44.3	20.1	1.3	230	60	4	3450
							0.98	460	60	2	3450
(S)TH211S290	5/300	13.1	11.42	290	44.8	20.3	1.4	230	60	4.2	3440
							1.06	460	60	2.1	3440
(S)TH212S390	5/325		15.35	390	45.0	20.4					
(S)TH213S390	5/355				45.2	20.5					
(S)TH214S390	5/375	14.1	15.35	390	47.8	21.7	1.7	230	60	4.8	3440
(S)TH215S390	5/395				48.1	21.8	1.27	460	60	2.4	3440
(S)TH216S390	5/420	15.0	15.35	390	61.7	28	2	230	60	5.4	3500
							1.49	460	60	2.7	3500
(S)TH217S490	5/440	15.0	19.29	490	66.6	30.2	2.3	230	60	6.2	3470
(S)TH218S490	5/480				66.8	30.3	1.75	460	60	3.1	3470
(S)TH219S490	5/505				67.0	30.4					
(S)TH220S490	5/540	16.0	19.29	490	71.7	32.5	2.6	230	60	7.0	3480
(S)TH221S490	5/570				71.9	32.6	1.95	460	60	3.5	3480
(S)TH222S590	5/605	17.3	23.23	590	82.5	37.4	2.9	230	60	7.8	3500
(S)TH223S590	5/635				82.7	37.5	2.18	460	60	3.9	3500
(S)TH224S590	5/660	17.3	23.23	590	84.2	38.2	3.4	230	60	8.8	3480
(S)TH225S590	5/690				84.7	38.4	2.55	460	60	4.4	3480
(S)TH226S590	5/715				84.9	38.5					
(S)TH227S690	5/740		27.17	690	86.2	39.1					
(S)TH228S690	5/760	17.3	27.17	690	88.6	40.2	3.9	230	60	10.2	3480
(S)TH229S690	5/785				88.9	40.3	2.94	460	60	5.1	3480
(S)TH230S690	5/810				89.1	40.4					
(S)TH231S690	5/835				89.3	40.5					

Dimensions in Inches / mm
*) Dimensions (S)TH203...215



Immersion Pumps

series TH and FH use closed impellers in order to minimize power consumption and to optimize hydraulic pump efficiencies.

In addition, the TH series offers high pressures at short immersion depths. Inline pumps of the series FH can be used as boosting pumps if provided with positive inlet pressure. This inlet pressure can be provided by the central coolant supply or a feed pump. In such a setup, pumps of the series FH can raise the incoming pressure by up to 375 PSI (26 bar).

Longer pump lengths and threaded inlets are available upon request.

Please see medium pressure pumps features in the Technical Information section of this catalog or call 248-926-9400 for details.

Applications

- Types of fluid
 - Industry water
 - coolants
 - cooling/cutting oils
- Kinematic viscosity
 - 4.6 SSU (1 mm²/s)
 - higher viscosity upon request
- Pumping temperature
 - 30...175 °F (0...80 °C)

Construction

Pump body	cast iron
Cover	cast iron
Impellers	CrNi-steel
Shaft	CrNi-steel
Diffusers	CrNi-steel
Mechanical seal	SiC
O-rings	Viton®
Optional:	
Pump body	bronze
	CrNi-steel
Cover	bronze
	CrNi-steel
Threaded inlet	G 1
Noise level (Motor only; Tolerance +3 dBA)	
(S)TH203...(S)TH215	61 dBA
(S)TH216...(S)TH231	66 dBA



Available Extended imm. depths:
790 mm (31.10"), 890 mm (35.04")

