

(S)TH2

50 Hz

Closed impellers

STH203...241

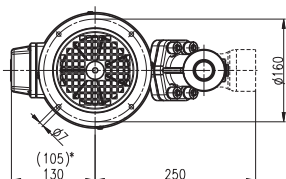
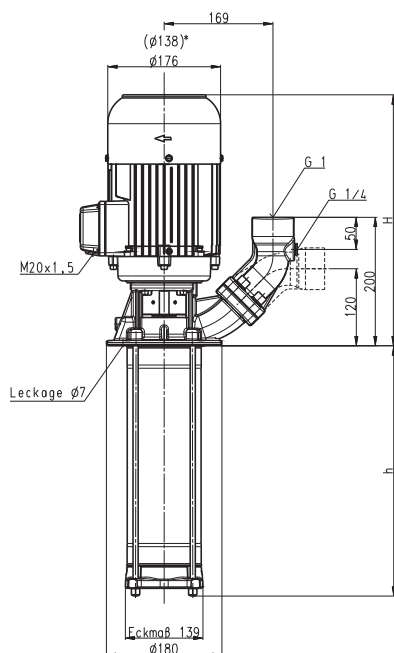

TH203...241

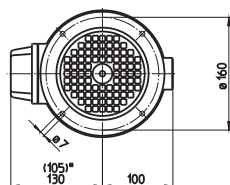
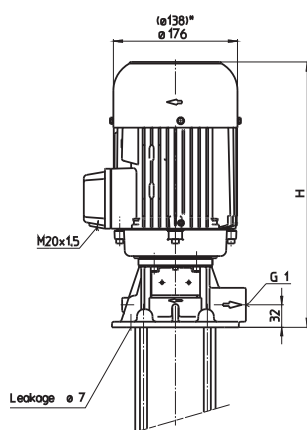

* Dimensions for (S)TH203...(S)TH222

Type	Vol. del. at manom. del. head l/min /m	Height H mm	Depth of im- mersion h mm	Weight kg	Power kW	Voltage 3 ~ V	Fre- quen- cy Hz	Current A	Speed 1/min
(S)TH203A190	20/15	291	190	14.9	0.48	220-240 380-415	50	2.06	2820
(S)TH204A190	20/20			15.0					
(S)TH205A190	20/25			15.1					
(S)TH206A190	20/30			15.2					
(S)TH207A290	20/35		290	15.7	0.63	220-240 380-415	50	2.70	2850
(S)TH208A290	20/40			15.8					
(S)TH209A290	20/45			15.9					
(S)TH210A290	20/50			16.0					
(S)TH211A290	20/56	332	290	17.4	0.75	220-240 380-415	50	3.24	2850
(S)TH212A390	20/60		390	17.9					
(S)TH213A390	20/68	332	390	20.0					
(S)TH214A390	20/75			20.1					
(S)TH215A390	20/82	332	390	21.4	0.92	220-240 380-415	50	3.8	2840
(S)TH216A390	20/88			21.5					
(S)TH217A490	20/93		490	22.1					
(S)TH218A490	20/98			22.2					
(S)TH219A490	20/102	359	490	24.1	1.1	220-240 380-415	50	4.33	2850
(S)TH220A490	20/108			24.2					
(S)TH221A490	20/112			24.3					
(S)TH222A590	20/118		590	24.9					
(S)TH223A590	20/125	381	590	31.0	1.3	220-240 380-415	50	4.85	2900
(S)TH224A590	20/130			31.2					
(S)TH225A590	20/135			31.3					
(S)TH226A590	20/142	381	590	31.5					
(S)TH227A690	20/150		690	32.4	1.5	220-240 380-415	50	5.5	2880
(S)TH228A690	20/155			32.5					
(S)TH229A690	20/160	407	690	34.3					
(S)TH230A690	20/166			34.4					
(S)TH231A690	20/172			34.5	1.7	220-240 380-415	50	6.24	2890
(S)TH232A790	20/178		790	36.4					
(S)TH233A790	20/182	439	790	40.9					
(S)TH234A790	20/190			41.0					
(S)TH235A790	20/195			41.1	1.9	220-240 380-415	50	3.95	2900
(S)TH236A790	20/200			41.2					
(S)TH237A890	20/205	439	890	43.0					
(S)TH238A890	20/210			43.1					
(S)TH239A890	20/215			43.2	2.2	220-240 380-415	50	7.8	2890
(S)TH240A890	20/220			43.3					
(S)TH241A890	20/225			43.4					

Immersion Pumps

series TH and FH use **closed impellers** in order to minimize power consumption and to optimize hydraulic pump efficiencies.

In addition, the TH series offers high pressures at short immersion depths. Inline pumps of the series FH can be used as **boosting pumps** if provided with positive inlet pressure. This inlet pressure can be provided by the central coolant supply or a feed pump. In such a setup, pumps of the series FH can raise the incoming pressure by up to 26 bar.

Extended length is possible. See medium pressure pumps features within the technical information section.

Applications

- Types of fluid
 - Industrial water
 - coolants
 - cooling/cutting oils
- Kinematic viscosity
 - 1 mm²/s (1 cSt)
 - higher viscosity upon request
- Pumping temperature
 - 0...80° C

Construction

Pump body	cast iron
Cover	cast iron
Impellers	CrNi-steel
Shaft	CrNi-steel
Diffusers	CrNi-steel
Mechanical seal	SiC
O-rings	Viton
Optional:	
Pump body	bronze
Cover	bronze
	CrNi-steel

Noise level	
(S)TH203...(S)TH222	58 dBA
(S)TH223...(S)TH241	63 dBA

