

Immersion Pumps

(S)TH11

Closed impellers



STH1102...1115

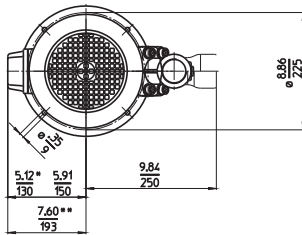
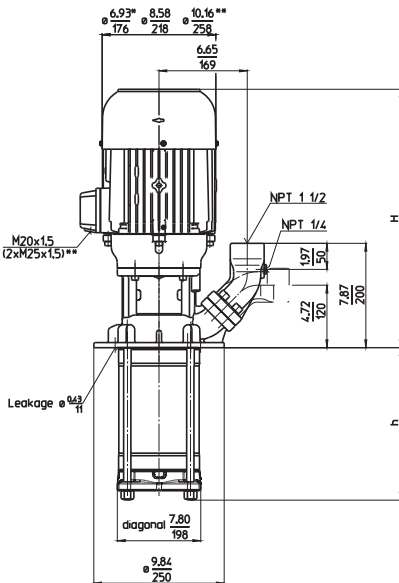

TH1102...1115

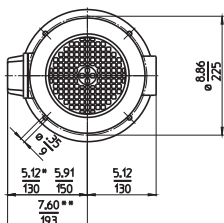
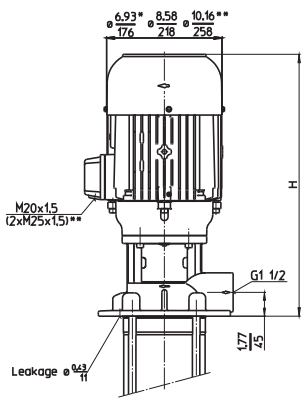

Type	Flow at head	Height	Depth of im- mersion		Weight		Power HP kW	Voltage 3~ V	Fre- quen- cy Hz	Current AMPS	Speed RPM
	GPM /Feet l/min /m	H inch mm	h inch	h mm	Lbs	kg					
(S)TH1102S180	37.5/100	17.0	7.17	182	75.0	34	2	230	60	5.4	3500
	150/30	433					1.49	460	60	2.7	3500
(S)TH1103S180	37.5/150	19.4	7.17	182	94.8	43	2.9	230	60	7.8	3500
	150/45	492					2.18	460	60	3.9	3500
(S)TH1104S280	37.5/200	19.4	10.94	278	97.0	44	3.9	230	60	10.2	3480
	150/59	492					2.94	460	60	5.1	3480
(S)TH1105S280	37.5/250	20.9	10.94	278	125.7	57	5.1	230	60	12.8	3520
	150/77	531					3.8	460	60	6.4	3520
(S)TH1106S280	37.5/300	20.9	10.94	278	127.9	58	6.1	230	60	15.8	3520
	150/90	531					4.55	460	60	7.9	3520
(S)TH1107S310	37.5/355	22.1	12.20	310	136.7	62	7.7	230	60	19.0	3520
	150/106	561					5.75	460	60	9.5	3520
(S)TH1108S380	37.5/400		14.72	374	141.1	64					
(S)TH1109S380	37.5/455	22.1	14.72	374	143.3	65	8.4	230	60	20.8	3510
	150/138	561					6.3	460	60	10.4	3510
(S)TH1110S470	37.5/510	25.2	18.50	470	214	97	11.5	230	60	27.8	3550
	150/152	640					8.6	460	60	13.9	3550
(S)TH1111S470	37.5/550				216	98					
(S)TH1112S470	37.5/600				218	99					
(S)TH1113S500	37.5/655	25.2	19.76	502	238	108	13.8	230	60	31.6	3550
	150/198	640					10.3	460	60	15.8	3550
(S)TH1114S570	37.5/705		22.28	566	240	109					
(S)TH1115S570	37.5/755				243	110					
	150/230										

Dimensions in Inches / mm
 *) Dimensions (S)TH1102...1104
 **) Dimensions (S)TH1110...1115



Immersion Pumps

series TH and FH use closed impellers in order to minimize power consumption and to optimize hydraulic pump efficiencies.

In addition, the TH series offers high pressures at short immersion depths. Inline pumps of the series FH can be used as boosting pumps if provided with positive inlet pressure. This inlet pressure can be provided by the central coolant supply or a feed pump. In such a setup, pumps of the series FH can raise the incoming pressure by up to 375 PSI (26 bar).

Longer pump lengths and threaded inlets are available upon request.

Please see medium pressure pumps features in the Technical Information section of this catalog or call 248-926-9400 for details.

Applications

- Types of fluid
 - Industry water
 - coolants
 - cooling/cutting oils
- Kinematic viscosity
 - ...115 SSU (...25 mm²/s)
- Pumping temperature
 - 30...175 °F (0...80 °C)

Construction

Pump body	cast iron
Cover	cast iron
Impellers	CrNi-steel
Shaft	CrNi-steel
Diffusers	CrNi-steel
Mechanical seal	SiC
O-rings	Viton®
Optional:	
Pump body	CrNi-steel
Cover	CrNi-steel
Threaded inlet	G 2
Noise level (Motor only; Tolerance +3 dBA)	
(S)TH1102...(S)TH1104	66 dBA
(S)TH1105...(S)TH1109	74 dBA
(S)TH1110...(S)TH1115	77 dBA



Available Extended imm. depths:
660 mm (25.98"), 760 mm (29.92")

