

Vertical End Suction Pumps

SBA1600S...2002S-V

Axial/semi-open impellers



SBA1600S...2002S-V

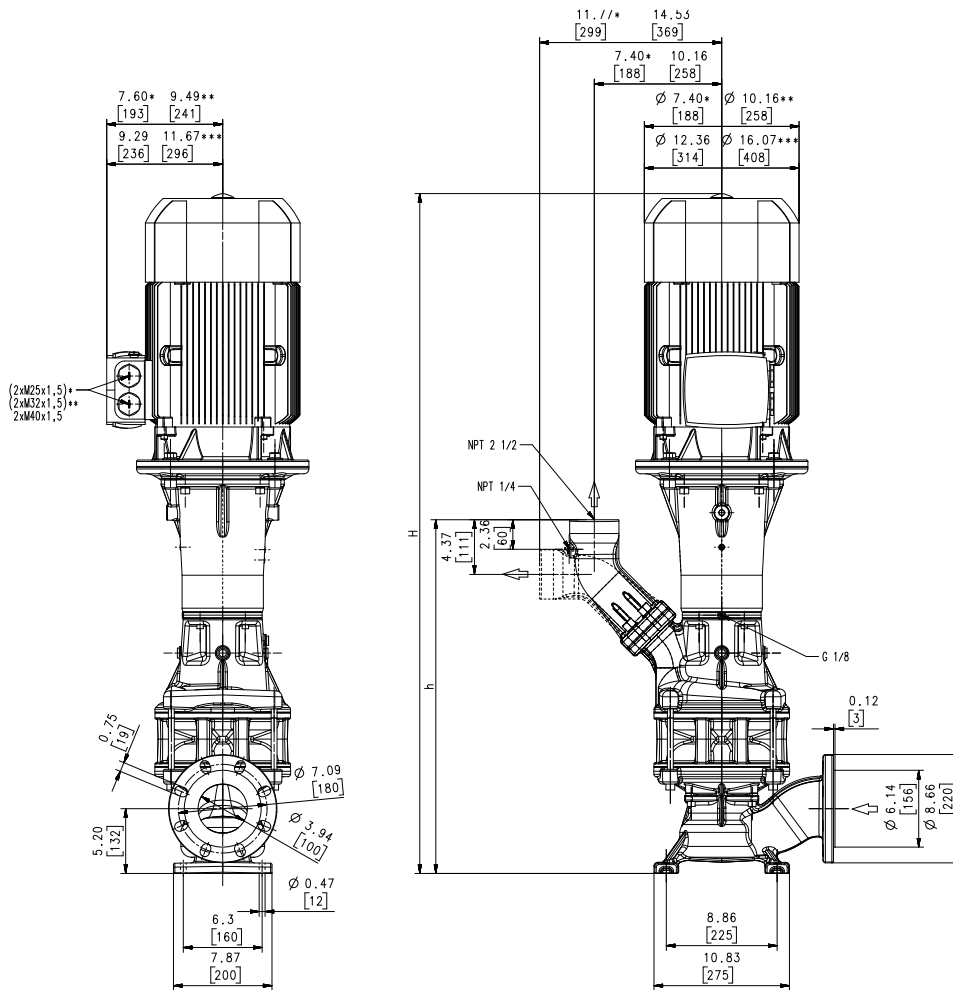

Dimensions in Inches / mm

*) Dimensions SBA1600S-V

**) Dimensions SBA2000S-V

***) Dimensions SBA2002S-V

Type	Flow at head	Dimensions				Weight		Power	Voltage	Fre-	Current	Speed
	GPM /Feet l/min /m	H inch	H mm	h inch	h mm	Lbs	kg	HP kW	3 ~ V	quency Hz	AMPS	RPM
SBA1600S-V	350/54	35.7	907	21.2	538	291	132	13.8	230	60	31.6	3550
	1400/15							10.3	460	60	15.8	3550
SBA2000S-V	450/60	36.1	916	24.0	609	351	159	16.9	230	60	39.2	3560
	1600/21							12.6	460	60	19.6	3560
SBA1602S-V	350/120	54.4	1381	28.3	719	503	228	25	460	60	28	3560
	1400/34							18.5				
SBA2002S-V	450/120	57.6	1462	28.3	719	553	251	40	460	60	47	3560
	1600/41							30.0				



Vertical End Suction Pumps

are centrifugal inline pumps with a compact design where the impeller is mounted onto the extended motor shaft. These pumps are not self-priming and must be gravity fed. All pumps are equipped with double mechanical seal. This pump series is designed for vertical installations next to a tank and for pumping **air entrained coolant fluids**, such as **water-soluble coolants or cutting oils**, as they occur in **high speed turning, milling or grinding applications**.

The SBA pumps are equipped with the user-friendly 45 degree **flange** connection which allows for either vertical or horizontal pipe connection and the connection of a pressure gauge with NPT 1/4. For more information see mechanical features within the technical information section.



Applications

- Types of fluid
 - coolants
 - cooling/cutting oils
- Kinematic viscosity
 - ...200 SSU (...45 mm²/s)
- Pumping temperature
 - 30...175 °F (0...80 °C)

Construction

Pump body	cast iron
Cover	cast iron
Impeller axial	cast steel
Impeller radial	cast steel
Shaft	steel
Mechanical seal	SiC
Noise level (Motor only; Tolerance +3 dBA)	
SBA1600S-V...SBA2000S-V	76 dBA
SBA1602S-V...SBA2002S-V	79 dBA

