

Pressure Boosting Pumps

FH2

Closed impellers



FH203...230

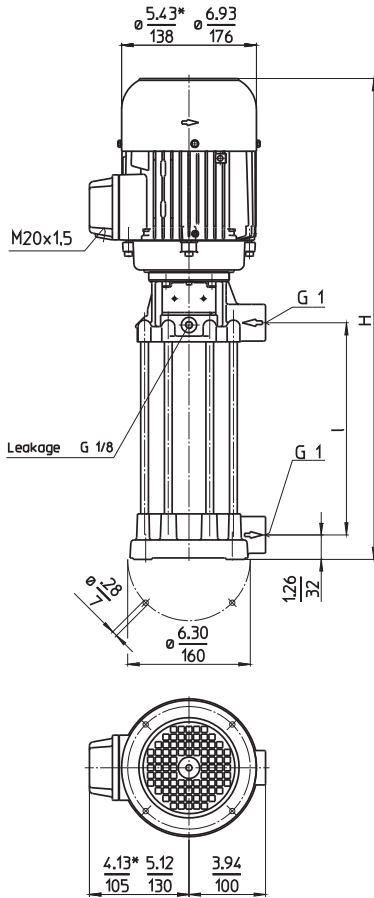

Dimensions in Inches / mm
*) Dimensions FH203...FH215

Type	Flow at head		Height		Length		Weight		Power HP kW	Voltage 3~ V	Fre- quen- cy Hz	Current AMPS	Speed RPM
	GPM /Feet	H inch	I Inch	I mm	Lbs	kg							
FH203S19	5/80	19.2	7.8	197	38.4	17.4	0.75	208-230	60	2.38	3405		
FH204S19	5/110				38.6	17.5	0.55	460	60	1.14	3405		
FH205S19	5/130				39.5	17.9							
FH206S29	5/165	23.1	11.7	297	40.6	18.4							
FH207S29	5/190	24.8	11.7	297	46.7	21.2	1	208-230	60	3.02	3425		
FH208S29	5/220				47.0	21.3	0.725	460	60	1.46	3425		
FH209S29	5/240	24.8	11.7	297	49.0	22.2	1.15	230	60	3.70	3440		
							0.86	460	60	1.85	3440		
FH210S29	5/270	24.8	11.7	297	51.4	23.3	1.3	230	60	4	3450		
							0.98	460	60	2	3450		
FH211S39	5/300	28.7	15.6	397	52.9	24.0	1.4	230	60	4.2	3440		
FH212S39	5/325				53.1	24.1	1.06	460	60	2.1	3440		
FH213S39	5/375				53.4	24.2							
FH214S39	5/395	29.8	15.6	397	56.0	25.4	1.7	230	60	4.8	3440		
FH215S39	5/420				56.2	25.5	1.27	460	60	2.4	3440		
FH216S49	5/440	34.6	19.6	497	68.4	31	2	230	60	5.4	3500		
							1.49	460	60	2.7	3500		
FH217S49	5/480	34.6	19.6	497	73.2	33.2	2.3	230	60	6.2	3470		
FH218S49	5/505				73.4	33.3	1.75	460	60	3.1	3470		
FH219S49	5/540				73.6	33.4							
FH220S49	5/570	35.6	19.6	497	78.3	35.5	2.6	230	60	7.0	3480		
							1.95	460	60	3.5	3480		
FH221S59	5/605	39.5	23.5	597	80.5	36.5							
FH222S59	5/635	40.8	23.5	597	89.1	40.4	2.9	230	60	7.8	3500		
FH223S59	5/660				89.3	40.5	2.18	460	60	3.9	3500		
FH224S59	5/690	40.8	23.5	597	90.8	41.2	3.4	230	60	8.8	3480		
FH225S59	5/715				91.3	41.4	2.55	460	60	4.4	3480		
FH226S69	5/740	44.7	27.4	697	92.6	42.0							
FH227S69	5/760				92.8	42.1							
FH228S69	5/785	44.7	27.4	697	95.0	43.1	3.9	230	60	10.2	3480		
FH229S69	5/810				95.5	43.3	2.94	460	60	5.1	3480		
FH230S69	5/835				95.9	43.5							



Pressure Boosting Pumps

series TH and FH use closed impellers in order to minimize power consumption and to optimize hydraulic pump efficiencies.

In addition, the TH series offers high pressures at short immersion depths. Inline pumps of the series FH can be used as boosting pumps if provided with positive inlet pressure. This inlet pressure can be provided by the central coolant supply or a feed pump. In such a setup, pumps of the series FH can raise the incoming pressure by up to 375 PSI (26 bar).

A frequency alternator can be supplied for special applications or for matching the pump characteristic to a specific duty point. See page "Control/Regulation" in the Technical Information section of this catalog for further information.

Applications

- Types of fluid
 - Industry water
 - coolants
 - cooling/cutting oils
- Kinematic viscosity
 - 4.6 SSU (1 mm²/s)
 - higher viscosity upon request
- Pumping temperature
 - 30...175 °F (0...80 °C)

Construction

Pump body	cast iron
Cover	cast iron
Impellers	CrNi-steel
Shaft	CrNi-steel
Diffusers	CrNi-steel
Mechanical seal	SiC
O-rings	Viton®
Optional:	
Pump body	bronze
Cover	bronze
Noise level (Motor only; Tolerance +3 dBA)	
FH203...FH215	61 dBA
FH216...FH230	66 dBA

