

BRINKMANN Immersion Pumps

STA/SAL2500, SGL2200, SFL2350

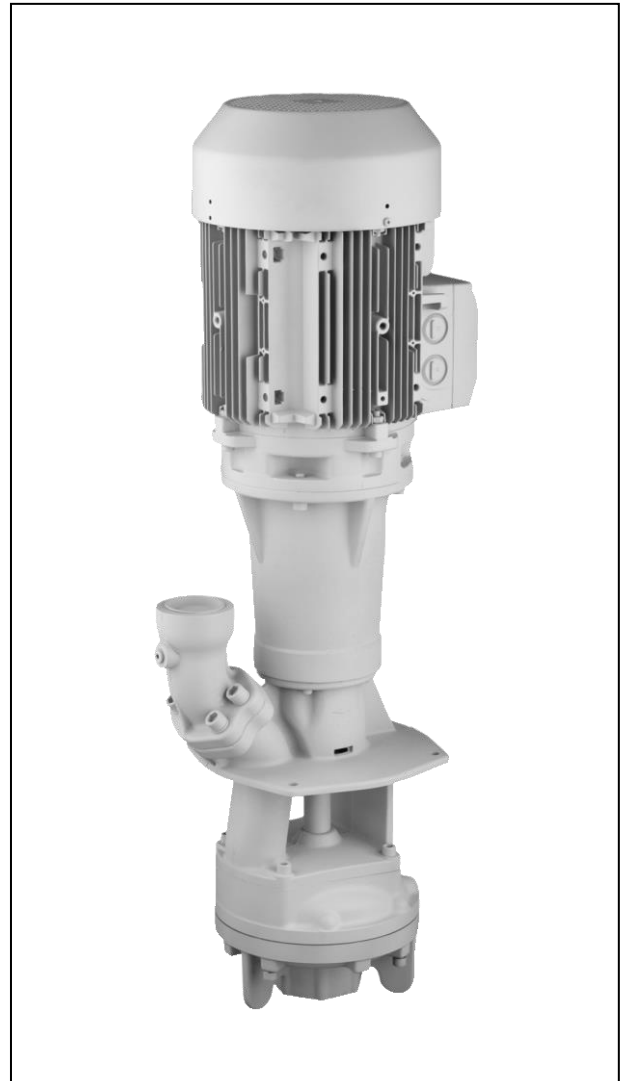

Brinkmann Pumpen
K. H. Brinkmann GmbH & Co. KG
Friedrichstraße 2 D-58791 Werdohl
Tel.: +49-2392 / 5006-0
Fax.: +49-2392 / 5006-180

www.brinkmannpumps.de
sales@brinkmannpumps.de

Subject to change without prior notice.

Order - No. : BE3350 ENGLISH

Brinkmann Immersions pumps of the series STA/SAL2500, SGL2200, SFL2350

Contents

| | | | | | |
|---|----------------------------------|-----|----|---------------------------------|-------|
| 1 | Indication to the manual | 2 | 9 | Trouble shooter's guide..... | 7 |
| 2 | Description of product | 2-3 | 10 | Spare part | 8-9 |
| 3 | Safety instructions | 4 | 11 | Repair | 9 |
| 4 | Transport and storage | 4 | 12 | Disposal | 9 |
| 5 | Installation and connection..... | 5 | 13 | Declarations of conformity..... | 10-11 |
| 6 | Start up / Shut down..... | 6 | | | |
| 7 | Operation..... | 6 | | | |
| 8 | Servicing and Maintenance | 6 | | | |

1 Indication to the manual

This operating manual gives basic instructions which are to be observed during installation, operation and maintenance of the pump. It is therefore imperative that this manual be read by the responsible personnel and operator prior to assembly and commissioning. It is always to be kept available at the installation site.

1.1 Identification of safety instructions in the operating manual

Safety instructions given in this manual non-compliance with which would affect **safety** are identified by the following symbol



Safety sign according with ISO 3864 – B.3.1

or where **electrical safety** is involved, with:



Safety sign according with ISO 3864 – B.3.6

Where non-compliance with the safety instructions may cause a risk to the machine and it's function the word

ATTENTION

is inserted.

2 Description of product

2.1 General description of the pump

Pumps of this type are one-stage rotary pumps where the impellers are fixed on the driving shaft extension. The pump shaft and motor shaft are interconnected by means of a shaft clamp. Pump and motor form a compact and space-saving unit. These pumps are fitted out with semi-open impellers and a suction screw SAL, SGL, SFL. Vertically mounted pumps are equipped with a mounting flange. The pump end immerses into the tank and the motor extends vertically above the tank.

2.2 Intended use

The immersion pumps of the series STA/SAL, SGL and SFL are suitable for handling contaminated coolants within the limiting application in accordance with table 1.

The pumps of SAL, SGL and SFL are suitable for handling extremely inflated fluids (grinding oils SGL).

Limit of Application (Table 1)

| Type | STA/SAL, SGL, SFL |
|---|---|
| Mediums | Coolants, cooling- and cutting-oils grinding oils SGL |
| Chip material SFL | Aluminium, steel, coloured steels max. chip to coolant ratio by weight: 1.0% |
| Kinetic viscosity of the medium | ...45 mm ² /s |
| Temperature of medium | 0 ... 80 °C |
| Particle-size in the medium | 27 mm STA2500 26 mm SAL2500 16mm SGL2200 28 mm SFL2350 |
| min. delivery volume | 1% of Q max. |
| Dry running | Dry running causes increased wear and should be avoided. During the test of the direction of rotation (< 30 s) permissible. |
| Switching-on frequency per hour for STA/SAL,SGL | Motors 10 kW to 22 kW max. 15 |
| SFL | The pump SFL should be operated in continual operation mode, not pulsed mode. |
| Ambient temperature | 40 °C |
| Set-up altitude | 1000 m |

ATTENTION

The pumps are to be operated within their design limits. Applications outside of these limits are not approved. The manufacturer is not responsible for any damages resulting from use of the pumps in such applications.

2.3 Technical data

| Type | Max. del. pressure bar / spec. weight 1 | Max. del. volume l/min | Height ¹⁾ H mm | Depth of immersion ¹⁾ h mm | Weight kg | Power 50 / 60 Hz kW | Noise level ²⁾ dBA / 50 Hz |
|---|---|------------------------|------------------------------|--|---------------------------------|------------------------|--|
| STA2500 / 330 / 460 / 580 / 830 /1080 | 5.2 | 2550 | 974 | 330 460 580 830 1080 | 200 205 210 227 230 | 18.5 / 21.3 | 78 |
| SAL2500 / 340 / 470 / 590 / 840 /1090 | 5.3 | 2600 | 974 | 340 470 590 840 1090 | 201 206 211 228 231 | 18.5 / 21.3 | |
| SGL2200 / 340 / 470 / 590 / 840 /1090 | 4.8 | 2600 | 974 | 340 470 590 840 1090 | 201 206 211 228 231 | 18.5 / 21.3 | |
| SFL2350 / 340 / 470 / 590 / 840 /1090 | 4.6 | 2450 | 974 | 340 470 590 840 1090 | 196 201 207 222 231 | 18.5 / 21.3 | |

1) Dimensions in accordance with page 5

2) Noise emissions measured in accordance with
DIN 45635 at a distance of 1 m

The motor is surface-cooled and compliant with
DIN IEC 34 and EN 60034 (protection degree IP 55).

3 Safety instructions

When operating the pump, the safety instructions contained in this manual, the relevant national accident prevention regulations and any other service and safety instructions issued by the plant operator are to be observed.

3.1 Hazards in the event of non-compliance with the safety instructions

Non-compliance with the safety instructions may produce a risk to the personnel as well as to the environment and the machine and results in a loss of any right to claim damages.

For example, non-compliance may involve the following hazards:

- Failure of important functions of the machines/plant
- Failure of specified procedures of maintenance and repair
- Exposure of people to electrical, mechanical and chemical hazards
- Endangering the environment due to hazardous substances being released

3.2 Unauthorized modes of operation



- Pump may not be used in potentially explosive environments!
- Pump and discharge piping are not designed to hold any weight and may not be used as a step ladder.

3.3 Remaining Risk



Risk of Injury!

Risk of squeezing or crushing body parts when installing or removing the pump exists. Proper and secured lifting tools must be used.

Risk of burns!

The pump must have cooled down sufficiently prior to commencing any repair, maintenance or installation.

3.4 Qualification and training of operating personnel

The personnel responsible for operation, maintenance, inspection and assembly must be adequately qualified. Scope of responsibility and supervision of the personnel must be exactly defined by the plant operator. If the staff does not have the necessary knowledge, they must be trained and instructed, which may be performed by the machine manufacturer or supplier on behalf of the plant operator. Moreover, the plant operator is to make sure that the contents of the operating manual are fully understood by the personnel.

3.5 Safety instructions relevant for operation

- If hot or cold machine components involve hazards, they must be guarded against accidental contact.

- Guards for moving parts (e.g. coupling) must not be removed from the machine while in operation.
- Any leakage of hazardous (e.g. explosive, toxic, hot) fluids (e.g. from the shaft seal) must be drained away so as to prevent any risk to persons or the environment. Statutory regulations are to be complied with.
- Hazards resulting from electricity are to be prevented (see for example, the VDE Specifications and the bye-laws of the local power supply utilities).
- The pumps' stability against falling over is not ensured unless it is properly mounted onto the tank.
- The female threads on the motor MUST NOT be used to lift the entire pump and motor assembly.

3.6 Safety instructions relevant for maintenance, inspection and assembly work

Any work on the machine shall only be performed when it is at a standstill, it being imperative that the procedure for shutting down the machine described in this manual be followed.

Pumps and pump units which convey hazardous media must be decontaminated.

On completion of work all safety and protective facilities must be re-installed and made operative again.

Prior to restarting the machine, the instructions listed under "Start up" are to be observed.

3.7 Signs on the pump

It is imperative that signs affixed to the machine, e.g.:

- arrow indicating the direction of rotation
- symbols indicating fluid connections be observed and kept legible.

3.8 Unauthorized alterations and production of spare parts

Any modification may be made to the machine only after consultation with the manufacturer. Using spare parts and accessories authorized by the manufacturer is in the interest of safety. Use of other parts may exempt the manufacturer from any liability.

4 Transport and storage

Protect the pump against damage when transporting.

The pumps may only be transported in a horizontal position and hooks or straps must be attached on the motor and pump end.

Do not use the pump shaft for connecting any transportation aids such as hooks or straps.

Pumps must be drained prior to their storage.

Store pump in dry and protected areas and protect it against penetration of foreign bodies.

Always store pump above the freezing point!

5 Installation and Connection

5.1 Mechanical installation

During any assembly or disassembly process the pumps must be secured against tipping through ropes for example at all times.

Pumps must be mounted securely. Piping, tank and pumps must be mounted without any tension.

The inlet is at the bottom of the immersed pump body. The distance between the inlet and the tank bottom must be so large that the inlet can not be blocked by deposits during longer shutdowns.

To obtain the full flow rate it is recommended to choose for the pipework the nominal bore diameter of the pumps cross section for connection. Therefore pipe bends should be used, not pipe angles!

The pipework must be qualified for occurring hydraulic pressure.

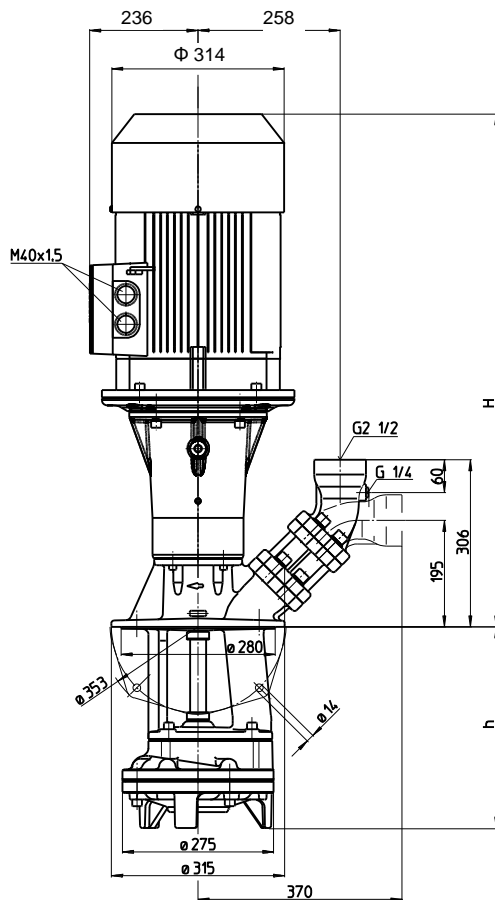

ATTENTION

Maximum tightening torque for piping connections is 200 Nm!

When installed the space around the pump must be large enough to provide sufficient cooling of the motor.

Do not prop up the pressure line via the joining socket.



The pump must be mounted in that way that rotating parts under the cover of the coolant tank cannot be touched!

5.2 Electric wiring



All service work must be carried out by qualified service personnel. Pump must be disconnected from the power source and all rotating parts must stand still. Reassure that pump is disconnected from power source and cannot be switched on. Verify that there is no voltage at the terminal board!

According to the European Standard EN809 a motor overload must be installed and properly set to the full load amps stated on the pump name plate.

It is the responsibility of the machine operator to decide whether or not an additional emergency switch must be installed.

5.2.1 Circuit



Tension voltage and frequency must correspond with the shown specification on the nameplate.

The pump must be wired so that a solid longterm electrical connection is ensured. Establish a solid ground connection.

The electrical wiring must be performed according to the wiring diagram shown inside the terminal box cover. (Please see above sample wiring diagrams)

Wiring diagram e.g.

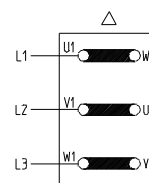

Delta connection
3 x 400 V, 50 Hz
resp. 380-415 V, 50 Hz

There may be no foreign objects such as dirt, particles or humidity inside the terminal board.

Mount terminal board cover to motor tight against dust and humidity and close up all unused wiring ports.

ATTENTION

When Variable Frequency Drives are used interfering signals might occur.

Non-sinus shaped supply voltage from a variable frequency drive might result in elevated motor temperatures.

6 Start up / Shut down

6.1 Start up

ATTENTION

Switch off at the mains.

After connection the electrical wires, close the terminal box. Briefly start the motor (max. 30 sec.) and check the rotation according to the arrow on the top of the motor.

If the direction is incorrect change over two of the power leads.

6.2 Shut down

All service work must be carried out by qualified service personnel. Pump must be disconnected from the power source and all rotating parts must stand still. Reassure that pump is disconnected from power source and cannot be switched on. Verify that there is no voltage at the terminal board! Open terminal box and disconnect the power leads. Empty out the pump.

7 Operation

Liquid level

According to the drawing shown below, the maximum liquid level must stay about 30 mm below the mounting flange, also ensure that the minimal liquid level for the STA pump is 80 mm before starting up the motor, for the SAL, SGL and SFL pumps the suction hole of the pump body must be covered with liquid.

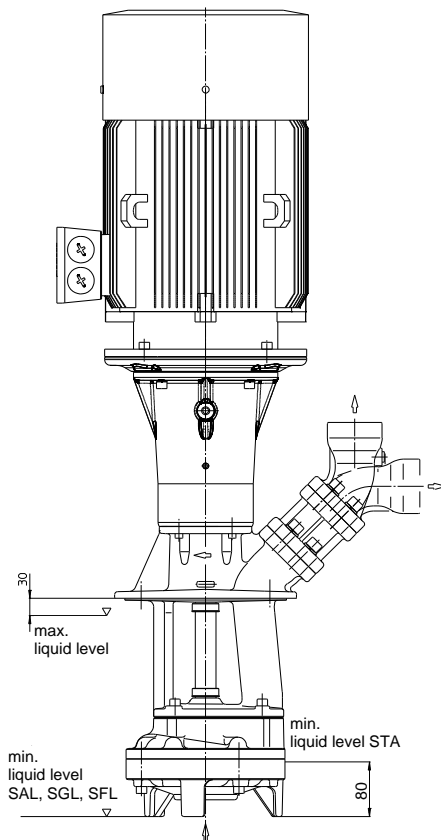

ATTENTION

The SFL pump should be operated in continual operation mode, not pulsed mode!

Pulsed mode causes increased wear due to the return flow of chips and additional load on the bearings

The pump should transport medium without chips for 1-2 minutes before being switched off!



If the pump should lock up and cease, shut pump down (see 6.2) and disconnect from power supply. Pump must be uninstalled and removed from the system prior to its repair.



Attention! Potential Risk of Burning!

Surface temperatures above 50°C do occur during regular operation, i.e. on the surfaces of the motor and bearing housing.

It must be insured that the pump has cooled down sufficiently prior to performing any repair or maintenance work.

8 Servicing and Maintenance

ATTENTION

The surface of the motor must be kept free of dirt.

The motor shaft is spinning in permanently greased ball bearings (with special grease and increased bearing play) and does not require any special maintenance.

9 Trouble shooter's guide

| Fault | Cause | Remedy |
|--------------------------------------|---|--|
| Motor does not start, no motor noise | At least two of the power supply leads have failed | Check fuses, terminals and supply leads. |
| | Overload has tripped | Inspect overload |
| Motor does not start, humming noise | One of the supply leads has failed | See above |
| | Impeller faulty Motor bearing faulty | Replace impeller Replace bearing |
| Overload trips | Pump locked up mechanically | Inspect pump hydraulics |
| | High on/of cycling frequency | Check application |
| Power consumption is too high | Wrong direction of rotation of impeller | See above |
| | Lime or other deposits mechanical friction | Clean pump mechanism repair pump |
| Motor overheats | High on/off cycling frequency | See above |
| | Wrong power supply (voltage or cycles) | Power supply must correspond with name plate rating |
| Pump does not pump | Insufficient cooling | Check air flow at motor fan |
| | liquid level too low Pump mechanism faulty Pipe blocked | Fill up liquid replace pump mechanism Clean pipe |
| Insufficient flow and pressure | Wrong direction of rotation of impeller | Change over two power supply leads |
| | Pump mechanism silted up Worn pump mechanism | Clean pump mechanism Replace pump mechanism |
| Incorrect flow or pressure | Wrong power supply (voltage or cycles) | Power supply must correspond with name plate rating |
| Running noise/Vibration | Foreign objects in pump end | Remove foreign objects |
| | Impeller damaged | Replace impeller |
| | Bearing/Bushing broken | Replace bearing/bushing |

10 Spare part

10.1 Spare part list for the immersion pumps of the series STA/SAL2500, SGL2200, SFL2350

| Item | Description | |
|------|--|----------|
| 1 | Motor | |
| 2 | Bearing housing | |
| 3 | Woodruff key | DIN 6888 |
| 4 | Bearing shaft | |
| 6 | Ball bearing | DIN 628 |
| 7 | Socket head cap screw | DIN 912 |
| 8 | Bearing cover | |
| 9 | Coupling | |
| 10 | Nilos-ring | |
| 11 | Threaded pin | DIN 705 |
| 12 | Shaft nut | |
| 13 | Distance liner | |
| 16 | Socket head cap screw | DIN 912 |
| 17 | Socket head cap screw | DIN 912 |
| 18 | Nilos-ring | |
| 19 | Compensation disk | |
| 50 | Pump body | |
| 52 | Inlet cover for STA | |
| 52 | Intake cover for SAL, SGL and SFL | |
| 54 | Pump plate | |
| 55 | Impeller | |
| 57 | Suction screw for SAL, SGL and SFL | |
| 58 | Extension pump body up 580 mm depth of immersion | |
| 61 | Bushing cartridge assembly | |
| 63 | Socket head cap screw with lock | DIN 912 |
| 64 | Woodruff key | DIN 6888 |
| 68 | Splash ring | |
| 70 | Socket head cap screw with lock | DIN 912 |
| 74 | Socket head cap screw with lock | DIN 912 |
| 77 | Hexagon thin nut for STA and SFL | |
| 78 | Socket head cap screw up 580 mm depth of immersion | DIN 912 |
| 79 | Balancing ring (as needed) | |
| 81 | Adapter | |
| 82 | Joining socket | |
| 83 | Socket head cap screw | DIN 912 |
| 84 | Spring washer | DIN 7980 |
| 85 | O-ring | |
| 86 | Screw plug | DIN 908 |
| 87 | Sealing ring | DIN 7603 |
| 91 | Extension shaft up 580 mm depth of immersion | |
| 92 | Insert shaft | |
| 93 | Shaft clamp 2 x up 580 mm depth of immersion | |

10.2 Indications to the spare part order

Spare parts are available from the supplier. Standard commercially available parts are to be purchased in accordance with the model type. The ordering of spare parts should contain the following details:

1. Pumptype

e.g. SFL2350 / 340

2. Pump No.

e.g. 0120233350

The date of the construction year is a component of the pumps type number.

3. Voltage, Frequency and Power

Take item 1, 2 and 3 from the nameplate

4. Spare part with item No.

e.g. Intake cover item No. 52

11 Repair Instructions / Replacing shaft clamps and shafts

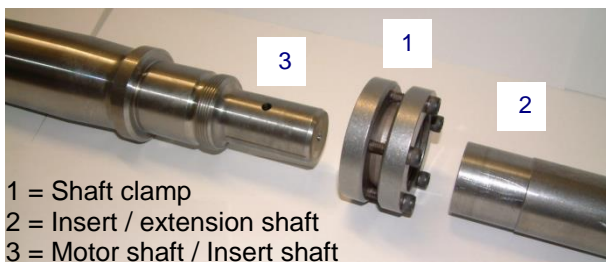

11.1 Dismantling the insert shaft or extension shaft

- Disconnect the submersible pump from the mains both electrically and mechanically.
- Remove pump from system. Secure pump against tipping over, i.e. use ropes to secure pump.
- Disassemble the motor. Set the pump down on the bearing housing. Dismantle the pump unit and the extension pump body (if appropriate).



Wear safety gloves!

Risk of injury due to sharp edges on pump components, i.e. impeller blades.

- Loosen the screws on the shaft clamp (1) one after the other.



Do not, under any circumstances, remove the screws completely, **danger of injury!**

- Remove the extension shaft (2) and shaft clamp (1).
- Dismantle the pump body.
- Loosen the screws on the shaft clamp (1) (see above), pull the insert shaft (2) off the motor shaft (3).

11.2 Assembling the insert shaft and motor shaft

ATTENTION

Clean the contact surfaces of the insert shaft (2) (inside) and the motor shaft (3). They must not be lubricated or oiled.

- Set the pump down on the bearing housing.
- Position the shaft clamp (1) (use a new shaft clamp) in the centre of the cranked clamping diameter (2) of the insert shaft.
- Insert the motor shaft (3) into the insert shaft (2).
- **Tighten:**
Mark the first screw and tighten all the screws evenly by hand, one after the other in a clockwise direction (not cross-ways).
- Use a torque screwdriver to tighten each screw first with 2 Nm then with 7 Nm and finally with 12 Nm (in a clockwise direction again).
- Mount the pump body.

The remainder of the reassembly process is to be completed in the opposite order of the prior described dismantling process.

ATTENTION

Note torques for the screw connections!

When putting the pump back into use, **make sure the direction of rotation is correct!**

Tightening torques for screwed connections

| Thread - Ø | M8 | M8 | M12 | M16 | M16 |
|------------------------|-------|------------------|----------------------|------------------|---|
| Strength classes | 8.8 | 12.9 | 8.8 | 8.8 | |
| Tightening torque (Nm) | 20 Nm | 40 Nm Item 17 | 80 Nm Item 70, 74 | 60 Nm Item 83 | 60 Nm Item 77 SFL 100 Nm Item 77 STA |

12 Disposal

When disposing of the pump or the packaging materials the local and national regulation for proper disposal must be complied with.

Prior to its disposal, the pump must be completely drained and decontaminated if necessary.

13 Declarations of conformity

13.1 UK declaration of conformity



UK declaration of conformity

Manufacturer

Brinkmann Pumpen, K. H. Brinkmann GmbH & Co. KG
Friedrichstraße 2
D-58791 Werdohl
Germany

This declaration of conformity is issued under the sole responsibility of Brinkmann Pumps and belongs to the following product.

Product name

Immersion pumps

Type **STA/SAL2500, SGL2200, SFL2350**

The named product described above complies with the following statutory requirements of United Kingdom:

UK SI 2008 No. 1597 The Supply of Machinery (Safety) Regulations 2008

UK SI 2016 No. 1091 The Electromagnetic Compatibility Regulations 2016

UK SI 2020 No. 1647 The Restriction of the Use of Certain Hazardous Substances in Electrical and Electronic Equipment Regulations 2020

The following exceptions in accordance with table 1, "Table of exempted applications" are claimed: No.12 (6a), No.15 (6b), No. 18 (6c)

The following designated standards and technical specification have been applied:

EN 809:1998+A1:2009+AC:2010

EN ISO 12100:2010

EN 60204-1:2018

EN IEC 61000-3-2 :2019

EN 61000-3-3 :2013+A1 :2019

EN IEC 61000-6-2 :2019

EN IEC 61000-6-3 :2021

EN IEC 63000 :2018

Additionally the following standard has been applied:

EN 60034-1 :2010/AC :2010

The instructions contained in the operating manual for installation and start up the pump have to be followed.

Brinkmann Pumpen, K. H. Brinkmann GmbH & Co.
KG

Werdohl, 16.01.2023

.....
Dr.-Ing. Dirk Wenderott
Chief Product Officer (CPO)
Head of Engineering

Dr. H. Abou Dayé
K. H. Brinkmann GmbH & Co. KG
Friedrichstraße 2, D-58791 Werdohl
Representative of documentation

13.2 EC declaration of conformity

DEUTSCH / ENGLISH / FRANÇAIS / ESPAÑOL



EG-Konformitätserklärung

EC declaration of conformity / Déclaration de conformité CE / Declaración de conformidad CE

Hersteller / Manufacturer / Constructeur / Fabricante

Brinkmann Pumpen, K. H. Brinkmann GmbH & Co. KG
Friedrichstraße 2, D-58791 Werdohl

Produktbezeichnung / Product name / Désignation du produit / Designación del producto

Tauchpumpen / Immersion pumps / Pompes plongeantes / Bombas de inmersión

Typ / Type / Tipo STA/SAL2500, SGL2200, SFL2350

Das bezeichnete Produkt stimmt mit den folgenden Richtlinien des Rates zur Angleichung der Rechtsvorschriften der EG-Mitgliedsstaaten überein:

The named product conforms to the following Council Directives on approximation of laws of the EEC Member States:
Le produit sus-mentionné est conforme aux Directives du Conseil concernant le rapprochement des législations des Etats membres CEE:

El producto designado cumple con las Directivas del Consejo relativas a la aproximación de las legislaciones de los Estados Miembros de la CEE:

| | |
|-----------------------------------|---|
| 2006/42/EG | Richtlinie für Maschinen |
| 2006/42/EC | Council Directive for machinery |
| 2006/42/CE | Directive du Conseil pour les machines |
| 2006/42/CE | Directivas del Consejo para máquinas |
| 2014/30/EU | Richtlinie für elektromagnetische Verträglichkeit |
| 2014/30/EU | Council Directive for Electromagnetic compatibility |
| 2014/30/UE | Directive du Conseil pour Compatibilité électromagnétique |
| 2014/30/UE | Directivas del Consejo para Compatibilidad electromagnética |
| 2011/65/EU und 2015/863/EU | RoHS Richtlinien |
| 2011/65/EU and 2015/863/EU | RoHS Directives |
| 2011/65/UE et 2015/863/UE | Directives RoHS |
| 2011/65/UE y 2015/863/UE | RoHS Directivas |

Folgende Ausnahmen gem. Anhang III RoHS (2011/65/EU) werden in Anspruch genommen: 6a, 6b, 6c.

The following exceptions in accordance with appendix III RoHS (2011/65/ EU) are claimed: 6a, 6b, 6c.

Les exceptions suivantes selon l'annexe III RoHS (2011 / 65 / UE) sont revendiquées : 6a, 6b, 6c.

Las siguientes excepciones conforme al apéndice III RoHS (2011/65 / UE) son requeridas: 6a, 6b, 6c.

Hinsichtlich der elektrischen Gefahren wurden gemäß Anhang I Nr. 1.5.1 der Maschinenrichtlinie 2006/42/EG die Schutzziele der Niederspannungsrichtlinie 2014/35/EU eingehalten.

With respect to potential electrical hazards as stated in appendix I No. 1.5.1 of the machine guide lines 2006/42/EC all safety protection goals are met according to the low voltage guide lines 2014/35/EU.

Conformément à l'annexe I N° 1.5.1 de la Directive "Machines" (2006/42/CE) les objectifs de sécurité relatifs au matériel électrique de la Directive "Basse Tension" 2014/35/UE ont été respectés.

Con respecto al potencial peligro eléctrico como se indica en el apéndice I No. 1.5.1 del manual de la máquina 2006/42/CE, todos los medios de protección de seguridad se encuentran según la guía de bajo voltaje 2014/35/UE.

Die Übereinstimmung mit den Vorschriften dieser Richtlinien wird nachgewiesen durch die vollständige Einhaltung folgender Normen:

Conformity with the requirements of this Directives is testified by complete adherence to the following standards:

La conformité aux prescriptions de ces Directives est démontrée par la conformité intégrale avec les normes suivantes:

La conformidad con las prescripciones de estas directivas queda justificada por haber cumplido totalmente las siguientes normas:

Harmonisierte Europ. Normen / Harmonised Europ. Standards / Normes europ. harmonisées / Normas europ. Armonizadas

| | | | |
|---------------------------------------|-------------------------------|-------------------------------|-------------------------------|
| EN 809 :1998+A1 :2009+AC :2010 | EN ISO 12100 :2010 | EN 60204-1 :2018 | EN IEC 61000-3-2 :2019 |
| EN 61000-3-3 :2013+A1 :2019 | EN IEC 61000-6-2 :2019 | EN IEC 61000-6-3 :2021 | EN IEC 63000 :2018 |

Nationale Normen / National Standards / Normes nationales / Normas nacionales : **EN 60034-1 :2010/AC :2010**

Die Hinweise in der Betriebsanleitung für den Einbau und die Inbetriebnahme der Pumpe sind zu beachten.

The instructions contained in the operating manual for installation and start up the pump have to be followed.

Les indications d'installation / montage et de mise en service de la pompe prévues dans l'instruction d'emploi doivent être suivies.

Tenga en cuenta las instrucciones en el manual para la instalación y puesta en marcha de la bomba.

Brinkmann Pumpen, K. H. Brinkmann GmbH & Co. KG

Werdohl, 16.01.2023

Dr.-Ing. Dirk Wenderott
Chief Product Officer (CPO)
Head of Engineering

Dr. H. Abou Dayé

K. H. Brinkmann GmbH & Co. KG
Friedrichstraße 2, D-58791 Werdohl

Dokumentationsbevollmächtigter / Representative of
documentation/ Mandataire de documentation /
Mandatario de documentación