

BE3124 Operating Instructions

(Translation of original)

BRINKMANN Cutter pumps

SXC2824 / SXC2824-H



Brinkmann Pumpen
K. H. Brinkmann GmbH & Co. KG
Friedrichstraße 2 D-58791 Werdohl
Tel.: +49-2392 / 5006-0
Fax.: +49-2392 / 5006-180

www.brinkmannpumps.de
sales@brinkmannpumps.de

Subject to change without prior notice.

Order - No.: BE3124 ENGLISH

Brinkmann Cutter pumps of the series SXC2824 / SXC2824-H

Contents

1	Indication to the manual	2	9	Trouble shooter's guide	9
2	Description of product.....	2	10	Spare part.....	10
3	Safety instructions	4	11	Repair Instructions / Replacing shaft clamps and shafts	11
4	Transport and storage	5	12	Disposal.....	12
5	Installation and Connection	5	13	Declarations of conformity	14
6	Start up / Shut down	7			
7	Operation.....	7			
8	Servicing and Maintenance	8			

1 Indication to the manual

This operating manual gives basic instructions which are to be observed during installation, operation and maintenance of the pump. It is therefore imperative that this manual be read by the responsible personnel and operator prior to assembly and commissioning. It is always to be kept available at the installation site.

1.1 Identification of safety instructions in the operating manual

Safety instructions given in this manual non-compliance with which would affect **safety** are identified by the following symbol:



Safety sign according with ISO
3864 – B.3.1

or where **electrical safety** is involved, with:



Safety sign according with ISO
3864 – B.3.6

The signal word **WARNING** indicates a hazardous situation which, if not avoided, could result in death or serious personal injury.

The signal word **CAUTION** indicates a hazardous situation which, if not avoided, could result in minor or moderate personal injury.

The signal word **ATTENTION** indicates a hazardous situation which, if not avoided, may cause a risk to the machine and it's function.

2 Description of product

2.1 General description of the pump

Pumps of the series SXC are one-stage rotary pumps. The impellers are fixed on the driving shaft extension. The pump shaft and motor shaft are interconnected by means of a shaft clamp.

The cutting unit is cutting the chips and the semi-open impeller with its large clearances allows to pump the particles along with the coolant fluid from the machine back to the filter. The SXC pumps are capable of handling chip to coolant ratios of up to 0.5% by weight.

The chips must be supplied to the suction mouth of the pump. Pump and motor form a compact and space-saving unit.

Vertically mounted pumps are equipped with a mounting flange. The pump end immerses into the tank and the motor extends vertically above the tank.

2.2 Intended use

The cutter pumps of the series SXC are designed to handle low alloyed steels, machining steel and cast iron / aluminum combinations. Chips can also be in the shape of birds nests or chip bundles.

– Pay attention of the limit of application in table 1!

The cutter pumps are intended for installation in machines and cannot be operated alone.

Limit of Application (Table 1)

Type	SXC
Mediums	Coolants, cooling- and cutting-oils on request.
Flashing point of the medium to be pumped	$\geq 150\text{ }^{\circ}\text{C}$
Chip material	Low alloyed steel, machining steel, cast iron/aluminum combinations max. chip to coolant ratio by weight: 0.5%
Chip geometry	Chip bundles to max. \varnothing 100 mm
Kinetic viscosity of the medium	...45 mm ² /s
Temperature of medium	0 ... 80 $^{\circ}\text{C}$
Dry running	Dry running causes increased wear and should be avoided. During the test of the direction of rotation (< 30 s) permissible.
Switching-on frequency per hour	The pump SXC should be operated in continual operation mode, not pulsed mode .
Ambient temperature	40 $^{\circ}\text{C}$
Set-up altitude	1000 m

**WARNING****Risk of fire and explosion!**

Pump may not be used in potentially explosive environments.

ATTENTION

The pumps are to be operated within their design limits.

Applications outside of these limits are not approved. The manufacturer is not responsible for any damages resulting from use of the pumps in such applications.

2.3 Technical data

Type	Max. del. pressure bar / spec. weight 1	Max. del. volume l/min	Height ¹⁾ H mm	Depth of immersion ¹⁾ h mm	Weight kg	Power (4-pole) 50 / 60 Hz kW
SXC2824-H/ SXC2824 / 480	2.0	1700	809	476	194	7.5 / 8.6
/ 610				606	196	
/ 730				726	199	

1) Dimensions in accordance with drawing 1.

The motor is surface-cooled and compliant with DIN IEC 34 and EN 60034 (protection degree IP 55).

3 Safety instructions

When operating the pump, the safety instructions contained in this manual, the relevant national accident prevention regulations and any other service and safety instructions issued by the plant operator are to be observed.

3.1 Hazards in the event of non-compliance with the safety instructions

Non-compliance with the safety instructions may produce a risk to the personnel as well as to the environment and the machine and results in a loss of any right to claim damages.

For example, non-compliance may involve the following hazards:

- Exposure of people to electrical, mechanical and chemical hazards
- Endangering the environment due to hazardous substances being released
- Failure of important functions of the machines/plant
- Failure of specified procedures of maintenance and repair

3.2 Unauthorized modes of operation

- Pump may not be used in potentially explosive environments. **Risk of explosion!**
- Pump and discharge piping are not designed to hold any weight and may not be used as a step ladder.

3.3 Remaining Risk

Risk of Injury!

Risk of squeezing or crushing body parts when installing or removing the pump exists.

- Proper and secured lifting tools must be used.

Risk of burns!

- The pump must have cooled down sufficiently prior to commencing any repair, maintenance or installation.

3.4 Qualification and training of operating personnel

- The personnel responsible for operation, maintenance, inspection and assembly must be adequately qualified.
- Scope of responsibility and supervision of the personnel must be exactly defined by the plant operator.
- If the staff does not have the necessary knowledge, they must be trained and instructed, which may be performed by the machine manufacturer or supplier on behalf of the plant operator. Moreover, the plant operator is to make sure that the contents of the operating manual are fully understood by the personnel.

3.5 Safety instructions relevant for operation

- If hot or cold machine components involve hazards, they must be guarded against accidental contact.
- Guards for moving parts (e.g. coupling) must not be removed from the machine while in operation.
- Any leakage of hazardous (e.g. explosive, toxic, hot) fluids (e.g. from the shaft seal) must be drained away so as to prevent any risk to persons or the environment. Statutory regulations are to be complied with.
- All service work must be carried out by qualified service personnel.
- The pumps' stability against falling over is not ensured unless it is properly mounted onto the tank.
- The female threads on the motor **MUST NOT** be used to lift the entire pump and motor assembly.
- Sharp-edged components (e.g. Impellers) must only be touched with suitable work protection, e.g. with protective gloves.
- Reassure that pump is disconnected from power source and cannot be switched on.

The by the machine generated noise level depends on the type of chip material pumped.

- It is the responsibility of the machine owner to ensure that no harm from noise is caused to the machine operating personnel. i.e. PPE such as ear protection should be supplied and worn by the operator.
- Local regulations with respect to maximum allowed noise levels must be complied with at all times.

3.6 Safety instructions relevant for maintenance, inspection and assembly work

- Any work on the machine shall only be performed when it is at a standstill, it being imperative that the procedure for shutting down the machine described in this manual be followed.
- Pumps and pump units which convey hazardous media must be decontaminated.
- On completion of work all safety and protective facilities must be re-installed and made operative again.
- Prior to restarting the machine, the instructions listed under "Start up" (see point 6.1) are to be observed.

3.7 Signs on the pump

- It is imperative that signs affixed to the machine, e.g:
 - arrow indicating the direction of rotation
 - symbols indicating fluid connections
- be observed and kept legible.

3.8 Unauthorized alterations and production of spare parts

Any modification may be made to the machine only after consultation with the manufacturer.

Using spare parts, standard parts, and accessories authorized by the manufacturer is in the interest of safety. Use of other parts may exempt the manufacturer from any liability.

4 Transport and storage



WARNING

Danger of clamping, crushing and cutting when transporting the pump!

- Protective packaging should remain on the pump end until its installation.
- The pumps may only be transported in a horizontal position and hooks or straps must be attached on the motor and pump end.

ATTENTION

- Protect the pump against damage when transporting.
- Pump may not be placed on its pump end!
- Do not use the pump shaft for connecting any transportation aids such as hooks or straps.



WARNING

Risk of injury by discharging fluid!

Pumping fluid that remains inside the pump after shut down can freeze during low temperature conditions and cause damage and cracks to pump components, such as the pump body. As a result, after restart of the pump the pumping fluid can then discharge through such cracks under high pressure and cause severe injury.

- Pumps must be drained prior to their storage.
- Store pump in dry and protected areas and protect it against penetration of foreign bodies.
- Always store pump above the freezing point!

5 Installation and Connection

5.1 Mechanical installation



WARNING

Risk of clamping or crushing body parts when installing or removing the pump exists!

- Pump must be secured with appropriate hoist.
- During any assembly or disassembly process the pumps must be secured against tipping trough ropes for example at all times.
- The pumps must be securely mounted to the tank.



CAUTION

Risk of cutting and crushing!

If the pipe work is installed under tension and with stress on the pump, the discharge port can break off and the pipe work can collapse.

- Discharge piping must be installed without tension or stress with proper support.
- Discharge piping must never be used as a step ladder.
- Do **not prop up** the pressure line via the joining socket.
- Piping, tank and pumps must be mounted **without any tension**.

ATTENTION

- Maximum tightening torque for piping connections is 170 Nm!

ATTENTION

- When installed the space around the pump must be large enough to provide sufficient cooling of the motor.

The inlet is at the bottom of the immersed pump body.

The bottom of the inlet cover must be located 50 mm above the tank bottom in order to prevent unwanted objects, such as broken tools or indexing plates from entering the pump suction. This distance is critical and must be maintained at all times.

- To obtain the full flow rate it is recommended to choose for the pipework the nominal bore diameter of the pumps cross section for connection.
- Pipe bends should be used, not pipe angles.
- The pipework must be qualified for occurring hydraulic pressure.

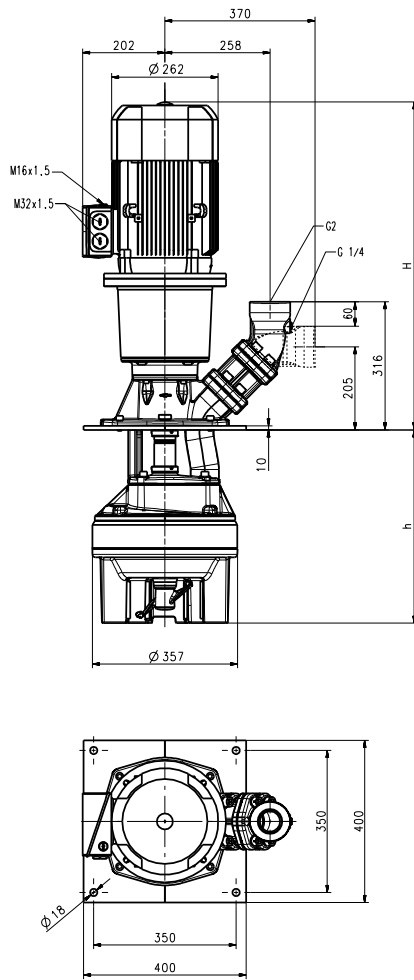

Drawing 1

**WARNING****Risk of injury by ejected parts!**

The pump may only be operated if installed within a suitable tank with proper enclosures!

- As particles and/or chips can be redirected from the pump suction at a high velocity, the tank design must incorporate appropriate protection, i.e. a tank cover, that prevents such objects from being ejected out off the tank.

**WARNING****Risk of crushing and cutting by moving parts!**

- The pump must be mounted in that way that rotating parts under the cover of the coolant tank can not be touched!

**WARNING****Risk of fire and explosion!**

The creation of an ignition spark with the presence of an ignitable aerosol can lead to risk of fire and explosion!

When pumping cooling- and cutting oils the following is to be adhered to:

- The geometry of the tank must be designed and executed in such a way that no flammable aerosol can develop (i.e. through velocity) during operation of the pump.
- The necessity of mist collection / exhaustion must be investigated and determined.
- In order to avoid the formation of an ignition spark, no foreign particles may enter the tank.

5.2 Electric wiring**WARNING****Electric shock!**

All service work must be carried out by qualified service personnel. Pump must be disconnected from the power source and all rotating parts must stand still. Reassure that pump is disconnected from power source and cannot be switched on.

- Verify that there is no voltage at the terminal board!
- According to the European Standard EN809 a motor overload must be installed and properly set to the full load amps stated on the pump name plate.

**WARNING****Risk of injury by uncontrolled start-up of the pump or by missing emergency shut off switch!**

Unwanted pump start-up or missing shut off switches can cause severe injury through ejected parts from the pump discharge or from cutting or pulling body parts into the pump suction.

- Reassure that pump is disconnected from power source and cannot be switched on.
- It is the responsibility of the machine operator to decide whether or not an additional emergency switch must be installed.

5.2.1 Circuit**WARNING****Electric shock!**

Tension voltage and frequency must correspond with the shown specification on the nameplate.

- The pump must be wired so that a solid longterm electrical connection is ensured.
- Establish a solid ground connection.

The electrical wiring must be performed according to the wiring diagram shown inside the terminal box cover.
(Please see above sample wiring diagrams):
Wiring diagram e.g.

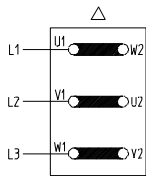

Delta connection
3 x 400 V, 50 Hz
resp. 380-415 V, 50 Hz

Drawing 2

There may be no foreign objects such as dirt, particles or humidity inside the terminal board.

- Mount terminal board cover to motor tight against dust and humidity and close up all unused wiring ports.

ATTENTION

When Variable Frequency Drives are used interfering signals might occur.
Non-sinus shaped supply voltage from a variable frequency drive might result in elevated motor temperatures.

6 Start up / Shut down

6.1 Start up

ATTENTION

- After connection the electrical wires, close the terminal box. Briefly start the motor (max. 30 sec.).
- Check the rotation according to the arrow on the top of the motor.

If the direction is incorrect change over two of the power leads.

6.2 Shut down



WARNING

Electric shock!

All service work must be carried out by qualified service personnel. Pump must be disconnected from the power source and all rotating parts must stand still. Reassure that pump is disconnected from power source and cannot be switched on.

- Verify that there is no voltage at the terminal board!
- Open terminal box and disconnect the power leads.
- Empty out the pump.

7 Operation



WARNING

Risk of injury by uncontrolled start-up of the pump or absence of emergency shutt of switch!

- Unwanted pump start-up or missing shut off switches can cause severe injury through ejected parts from the pump discharge or from cutting or pulling body parts into the pump suction.
- Reassure that pump is disconnected from power source and cannot be switched on.
- It is the responsibility of the machine operator to decide whether or not an additional emergency switch must be installed.

Liquid level

According to the drawing 3, the maximum liquid level must stay about 30 mm below the mounting flange, also ensure that the minimal liquid level for the SXC pump is 110 mm or 160 mm (see drawing 3) before starting up the motor.

The pump suction is at the bottom of the immersed pump body.

The bottom of the inlet cover must be located 50 mm above the tank bottom in order to prevent unwanted objects, such as broken tools or indexing plates from entering the pump suction.

This distance is critical and must be maintained at all times.

- By means of suitable tank geometry the chips are to be led to the suction mouth of the pump.

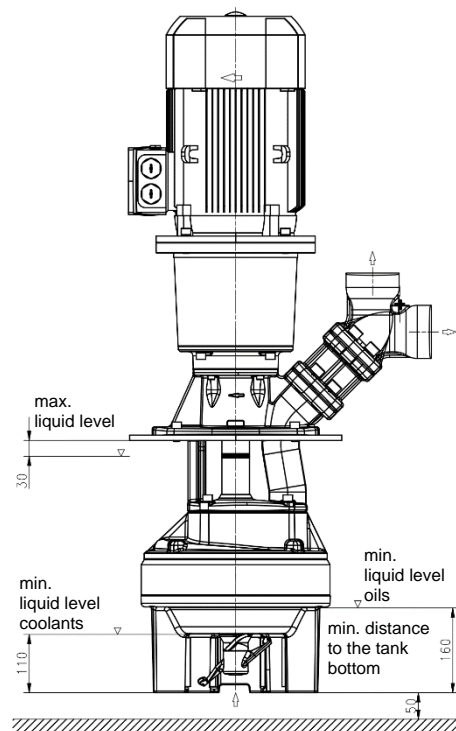

Drawing 3

**WARNING****Risk of fire and explosion!**

The creation of an ignition spark with the presence of an ignitable Aerosol can lead to risk of fire and explosion.

The fluid level during operation with cooling and cutting oils must therefore always be above the cutting mechanism to fully cover it in order to avoid the possibility of the creation of an ignition spark.

- Unwanted objects, such as broken tools or indexing plates which still lie under the pump after stopping the working process must be taken out in regular intervals!
- Any repair or maintenance work must be performed after the pump has been turned off and the shaft has come to a complete stop. Risk of injury!
See provided warning label!
- If the pump should lock up and cease, shut pump down (see point 6.2) and disconnect from power supply. Pump must be uninstalled and removed from the system prior to its repair.

ATTENTION

Pulsed mode causes increased wear due to the return flow of chips and additional load on the bearings.

- The SXC pump should be operated in continual operation mode, **not pulsed mode!**
- The pump should transport medium without chips for 1-2 minutes before being switched off!

8 Servicing and Maintenance**CAUTION****Risk of burns!**

- The pump must have cooled down sufficiently prior to commencing any repair, maintenance or installation.

**WARNING****Risk of injury through contaminated parts!**

- Pumps and pump units which convey hazardous media must be decontaminated.

ATTENTION

- The surface of the motor must be kept free of dirt.

The motor shaft is spinning in permanently greased ball bearings and does not require any special maintenance.

- On completion of work all safety and protective facilities must be re-installed and made operative again.
- Prior to restarting the machine, the instructions listed under “Start up” (point 6.1) are to be observed

9 Trouble shooter's guide

Fault	Cause	Remedy
Motor does not start, no motor noise	At least two of the power supply leads have failed	Check fuses, terminals and supply leads.
	Overload has tripped	Inspect overload
Motor does not start, humming noise	One of the supply leads has failed	See above
	Impeller faulty Motor bearing faulty	Replace impeller Replace bearing
Overload trips	Pump locked up mechanically	Inspect pump hydraulics
	High on/of cycling frequency	Check application
Power consumption is too high	Wrong direction of rotation of impeller	See above
	Lime or other deposits mechanical friction	Clean pump mechanism repair pump
Motor overheats	High on/off cycling frequency	See above
	Wrong power supply (voltage or cycles)	Power supply must correspond with name plate rating
Pump does not pump	Insufficient cooling	Check air flow at motor fan
	liquid level too low Pump mechanism faulty Pipe blocked	Fill up liquid replace pump mechanism Clean pipe
The pump pumps no chips	Chip breaker worn or damage	Replace the chip breaker
Insufficient flow and pressure	Wrong direction of rotation of impeller	Change over two power supply leads
	Pump mechanism silted up Worn pump mechanism	Clean pump mechanism Replace pump mechanism
Incorrect flow or pressure	Wrong power supply (voltage or cycles)	Power supply must correspond with name plate rating
Running noise/Vibration	Foreign objects in pump end	Remove foreign objects
	Impeller damaged	Replace impeller
	Bearing/Bushing broken	Replace bearing/bushing

10 Spare part

10.1 Spare part list for the immersion pumps of the series SXC2824

	Item	Description	
	1	Motor	
	2	Bearing flange	
	3	Pump housing	
	4	Bearing shaft	
	5	Woodruff key	
	6	Coupling	
	9	Ball bearing	DIN 628
	11	Socket head cap screw	DIN 912
	12	Socket head cap screw with lock with spring washer	DIN 912 DIN 7980
	17	Socket head cap screw with lock	DIN 912
	20	Bearing cover	
	21	Retaining ring	DIN 7603
	22	Shaft nut	
	50	Pump body	
	52	Shaft seal	
	53	Intake cover	
	54	Socket head cap screw with lock	DIN 912
	55	Washer	
	56	Chip breaker	
	57	Bearing bush	
	58	Socket head cap screw with lock	DIN 7984
	59	Inlet cover	
	60	Socket head cap screw with lock	DIN 7984
	61	Bushing cartridge assembly	
	65	Socket head cap screw with lock	DIN 912
	66	Pump sheets	
	67	Socket head cap screw with lock	DIN 912
	68	Distance plate	
	70	Insert shaft	
	71	Shaft clamp	
	72	Splash ring	
	75	Impeller	
	76	Key	DIN 6885
	78	Suction screw	
	79	Key	DIN 6885
	80	Shaft nut	
	81	Agitator	
	82	Socket head cap screw with lock	DIN 912
	83	Pump plate	
	84	Socket head cap screw with lock	DIN 912
	85	Serrated lock washer	
	86	Hard metal plates	
	87	Scraper SXC2824-H	
	88	Wear protection SXC2824-H	
	92	Joining socket	
	93	Socket head cap screw	DIN 912
	94	Spring washer	DIN 7980
	95	O-ring	
	96	Screw plug	DIN 908
	97	Sealing ring	DIN 7603
	98	Adapter	

Drawing 4

10.2 Indications to the spare part order

Spare parts are available from the supplier. Standard commercially available parts are to be purchased in accordance with the model type. The ordering of spare parts should contain the following details:

1. Pumptype

e.g. SXC2824 / 480

2. Pump No.

e.g. 0120233124

The date of the construction year is a component of the pumps type number.

3. Voltage, Frequency and Power

Take item 1, 2 and 3 from the nameplate

4. Spare part with item No.

e.g. Intake cover item No. 53

11 Repair Instructions / Replacing shaft clamps and shafts

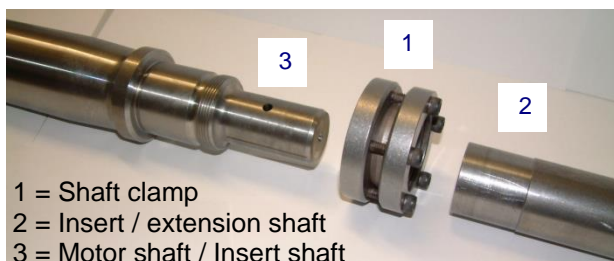

Drawing 5

11.1 Dismantling the insert shaft or extension shaft

- Disconnect the submersible pump from the mains both electrically and mechanically.



CAUTION

Risk of burns!

- The pump must have cooled down sufficiently prior to commencing any repair or maintenance.



WARNING

Risk of squeezing or crushing body parts when installing or removing the pump exists!

- Secure pump with appropriate hoist.
- Remove pump from system. Secure pump against tipping over, i.e. use ropes to secure pump.
- Disassemble the motor.
- Set the pump down on the pump housing.
- Dismantle the pump unit and the extension pump body (if appropriate).



WARNING

Risk of injury due to sharp edges on pump components, i.e. impeller blades!

- Wear safety gloves!



WARNING

Risk of injury by discharging parts!

- Do not, under any circumstances, remove the screws on the shaft clamp (1) completely.
- Remove the extension shaft (2) and shaft clamp (1).
- Dismantle the pump body.
- Loosen the screws on the shaft clamp (1) (see above), pull the insert shaft (2) off the motor shaft (3).

11.2 Assembling the insert shaft and motor shaft



WARNING

Risk of jamming or crushing during pump installation or removal!

- Secure pump with appropriate hoist.

ATTENTION

- Clean the contact surfaces of the insert shaft (2) (inside) and the motor shaft (3). They must not be lubricated or oiled.
- Set the pump down on the pump housing.
- Position the shaft clamp (1) (use a new shaft clamp) in the centre of the cranked clamping diameter (2) of the insert shaft.
- Insert the motor shaft (3) into the insert shaft (2).
- Tighten:
Mark the first screw and tighten all the screws evenly by hand, one after the other in a clockwise direction (not cross-ways).
- Use a torque screwdriver to tighten each screw first with 12 Nm then with 24 Nm and finally with 35 Nm (in a clockwise direction again).
- Repeat the last turn (with 35 Nm) 3 times.

**WARNING**

Risk of injury due to sharp edges on pump components, i.e. impeller blades!

- Wear safety gloves!
- Install the motor.
- The remainder of the reassembly process is to be completed in the opposite order of the prior described dismantling process.

ATTENTION

Assembly help and detailed instruction is demanded for the assembly of the pump and adjusting of the cutting unit!

- Request the required documents from the manufacturer.
- Note torques for the screw connections!

Tightening torques for screwed connections

Thread - Ø	M5	M6	M8	M12	M16
Strength classes	8.8	8.8	8.8	8.8	8.8
Tightening torque (Nm)	3 Nm	4.5 Nm	20 Nm	80 Nm Item 54, 60, 84	60 Nm Item 93 100 Nm Item 54

- Pump Installation. Secure pump against falling over. i.e. with use of safety straps.
- Reconnect immersion pump as described in point 5.

ATTENTION

- When putting the pump back into use, **make sure the direction of rotation is correct** (see point 6.1)!

12 Disposal

When disposing of the pump or the packaging materials the local and national regulation for proper disposal must be complied with.

- Prior to its disposal, the pump must be completely drained and decontaminated if necessary.

13 Declarations of conformity

13.1 UK declaration of conformity



UK declaration of conformity

Manufacturer

Brinkmann Pumpen, K. H. Brinkmann GmbH & Co. KG
Friedrichstraße 2
D-58791 Werdohl
Germany

This declaration of conformity is issued under the sole responsibility of Brinkmann Pumps and belongs to the following product.

Product name

Cutter Pumps

Type **SXC2824 / SXC2824-H**

The named product described above complies with the following statutory requirements of United Kingdom:

UK SI 2008 No. 1597 The Supply of Machinery (Safety) Regulations 2008

UK SI 2016 No. 1091 The Electromagnetic Compatibility Regulations 2016

UK SI 2020 No. 1647 The Restriction of the Use of Certain Hazardous Substances in Electrical and Electronic Equipment Regulations 2020

The following exceptions in accordance with table 1, "Table of exempted applications" are claimed: No.12 (6a), No.15 (6b)

The following designated standards and technical specification have been applied:

EN 809:1998+A1:2009+AC:2010

EN ISO 12100:2010

EN 60204-1:2018

EN IEC 61000-3-2 :2019

EN 61000-3-3 :2013+A1 :2019

EN IEC 61000-6-2 :2019

EN IEC 61000-6-3 :2021

EN IEC 63000 :2018

Additionally the following standard has been applied:

EN 60034-1 :2010/AC :2010

The instructions contained in the operating manual for installation and start up the pump have to be followed.

Brinkmann Pumpen, K. H. Brinkmann GmbH & Co.
KG

Werdohl, 16.01.2023

.....
Dr.-Ing. Dirk Wenderott
Chief Product Officer (CPO)
Head of Engineering

Dr. H. Abou Dayé
K. H. Brinkmann GmbH & Co. KG
Friedrichstraße 2, D-58791 Werdohl
Representative of documentation

