

BE8082 Operating Instructions  
(Translation of original)

---

**BRINKMANN-Horizontal End Suction Pumps**  
**SBC820...1120**



**Brinkmann Pumpen**  
**K. H. Brinkmann GmbH & Co. KG**  
Friedrichstraße 2 D-58791 Werdohl  
Tel.: +49-2392 / 5006-0  
Fax.: +49-2392 / 5006-180

[www.brinkmannpumps.de](http://www.brinkmannpumps.de)  
[sales@brinkmannpumps.de](mailto:sales@brinkmannpumps.de)

Subject to change without prior notice.

Order - No.: BE8082 ENGLISH

## Brinkmann–Horizontal End Suction Pumps Series SBC820...1120

### Contents

1	Indication to the manual .....	2	9	Trouble shooter's guide .....	9
2	Description of product.....	2	10	Spare part.....	10
3	Safety instructions .....	4	11	Repair Instructions / Replacing the rotary mechanical seal / the shaft clamp.....	11
4	Transport and storage .....	5	12	Disposal.....	13
5	Installation and Connection .....	5	13	Declarations of conformity .....	14
6	Start up / Shut down .....	7			
7	Operation.....	7			
8	Servicing and Maintenance .....	8			

## 1 Indication to the manual

This operating manual gives basic instructions which are to be observed during installation, operation and maintenance of the pump. It is therefore imperative that this manual be read by the responsible personnel and operator prior to assembly and commissioning. It is always to be kept available at the installation site.

### 1.1 Identification of safety instructions in the operating manual

Safety instructions given in this manual non-compliance with which would affect **safety** are identified by the following symbol:



Safety sign according with ISO  
3864 – B.3.1

or where **electrical safety** is involved, with:

Safety sign according with ISO  
3864 – B.3.6

The signal word **WARNING** indicates a hazardous situation which, if not avoided, could result in death or serious personal injury.

The signal word **CAUTION** indicates a hazardous situation which, if not avoided, could result in minor or moderate personal injury.

The signal word **ATTENTION** indicates a hazardous situation which, if not avoided, may cause a risk to the machine and it's function.

## 2 Description of product

### 2.1 General description of the pump

Pumps of the series SBC are one-stage rotary pumps. The impellers are fixed on the driving shaft extension. The pump shaft and motor shaft are interconnected by means of a shaft clamp.

The cutting unit is cutting the chips and the semi-open impeller with its large clearances allows to pump the particles along with the coolant fluid from the machine back to the filter. The SBC pumps are capable of handling chip to coolant ratios of up to 1.5% by weight.

Pump and motor form a compact and space-saving unit.

All pumps are equipped with double mechanical seal.

These pumps are for horizontal installations next to or underneath a tank. The pumps are foot mounted and must be screwed down in order to ensure a secure stance.

### 2.2 Intended use

These pumps are not self-priming and must be gravity fed.

The pumps of the series SBC are suited for cutting aluminum chips or similar materials and for pumping these materials along with the coolant fluid.

An agitator located at the pump suction helps to break up and separate any large bundles of chips or birds' nests which reach the pump suction.

– Pay attention of the limit of application in table 1!

The cutter pumps are intended for installation in machines and cannot be operated alone.

**Limit of Application (Table 1)**

Type	SBC
Mediums	Coolants, cooling- and cutting-oils on request.
Flashing point of the medium to be pumped	$\geq 150$ °C
Chip material	Aluminium max. chip to coolant ratio by weight: 1.5%
Chip geometry	Chip bundles to max. $\varnothing$ 100 mm
Kinetic viscosity of the medium	...45 mm <sup>2</sup> /s
Temperature of medium	0 ... 80 °C
Dry running	Dry running causes increased wear and should be avoided. During the test of the direction of rotation (< 30 s) permissible.
min. delivery volume	1.5 % of Q max.
Switching-on frequency per hour	The pump SBC should be operated in continual operation mode, <b>not pulsed mode</b> .
Ambient temperature	40 °C
Set-up altitude	1000 m

**WARNING****Risk of fire and explosion!**

Pump may not be used in potentially explosive environments.

**ATTENTION**

The pumps are to be operated within their design limits.

Applications outside of these limits are not approved. The manufacturer is not responsible for any damages resulting from use of the pumps in such applications.

**2.3 Technical data**

Type	Max. del. pressure bar / spec. weight 1	Max. del. volume l/min	Dimensions		Length l mm	Weight kg	Power 50 / 60 Hz kW
			H mm	h mm			
SBC820	1.6	1000	780	518	328	85	4.0 / 4.55
SBC1120	2.0	1100	810	518	358	89	5.5 / 6.3

Pipe connection: Suction side DN125/PN16,  
Pressure side G 2.

The motor is surface-cooled and compliant with DIN IEC 34 and EN 60034 (protection degree IP 55).

### 3 Safety instructions

When operating the pump, the safety instructions contained in this manual, the relevant national accident prevention regulations and any other service and safety instructions issued by the plant operator are to be observed.

#### 3.1 Hazards in the event of non-compliance with the safety instructions

Non-compliance with the safety instructions may produce a risk to the personnel as well as to the environment and the machine and results in a loss of any right to claim damages. For example, non-compliance may involve the following hazards:

- Exposure of people to electrical, mechanical and chemical hazards
- Endangering the environment due to hazardous substances being released
- Failure of important functions of the machines/plant
- Failure of specified procedures of maintenance and repair

#### 3.2 Unauthorized modes of operation

- Pump may not be used in potentially explosive environments. **Risk of explosion!**
- Pump and discharge piping are not designed to hold any weight and may not be used as a step ladder.

#### 3.3 Remaining Risk

##### Risk of Injury!

Risk of squeezing or crushing body parts when installing or removing the pump exists.

- Proper and secured lifting tools must be used.

##### Risk of burns!

- The pump must have cooled down sufficiently prior to commencing any repair, maintenance or installation.

#### 3.4 Qualification and training of operating personnel

- The personnel responsible for operation, maintenance, inspection and assembly must be adequately qualified.
- Scope of responsibility and supervision of the personnel must be exactly defined by the plant operator.
- If the staff does not have the necessary knowledge, they must be trained and instructed, which may be performed by the machine manufacturer or supplier on behalf of the plant operator. Moreover, the plant operator is to make sure that the contents of the operating manual are fully understood by the personnel.

#### 3.5 Safety instructions relevant for operation

- If hot or cold machine components involve hazards, they must be guarded against accidental contact.
- Guards for moving parts (e.g. coupling) must not be removed from the machine while in operation.
- Any leakage of hazardous (e.g. explosive, toxic, hot) fluids (e.g. from the shaft seal) must be drained away so as to prevent any risk to persons or the environment. Statutory regulations are to be complied with.
- All service work must be carried out by qualified service personnel.
- The pumps are only secured safely if properly attached to the floor or underneath a tank.
- The female threads on the motor **MUST NOT** be used to lift the entire pump and motor assembly.
- Sharp-edged components (e.g. Impellers) must only be touched with suitable work protection, e.g. with protective gloves.
- Reassure that pump is disconnected from power source and cannot be switched on.

The by the machine generated noise level depends on the type of chip material pumped.

- It is the responsibility of the machine owner to ensure that no harm from noise is caused to the machine operating personnel. i.e. PPE such as ear protection should be supplied and worn by the operator.
- Local regulations with respect to maximum allowed noise levels must be complied with at all times.

#### 3.6 Safety instructions relevant for maintenance, inspection and assembly work

- Any work on the machine shall only be performed when it is at a standstill, it being imperative that the procedure for shutting down the machine described in this manual be followed.
- Pumps and pump units which convey hazardous media must be decontaminated.
- On completion of work all safety and protective facilities must be re-installed and made operative again.
- Prior to restarting the machine, the instructions listed under "Start up" (see point 6.1) are to be observed.

#### 3.7 Signs on the pump

- It is imperative that signs affixed to the machine, e.g:
  - arrow indicating the direction of rotation
  - symbols indicating fluid connections be observed and kept legible.

### 3.8 Unauthorized alterations and production of spare parts

Any modification may be made to the machine only after consultation with the manufacturer.

Using spare parts, standard parts, and accessories authorized by the manufacturer is in the interest of safety. Use of other parts may exempt the manufacturer from any liability.

## 4 Transport and storage



### WARNING

#### Danger of clamping, crushing and cutting when transporting the pump!

- Protective packaging should remain on the pump end until its installation.
- The pumps may only be transported in a horizontal position and hooks or straps must be attached on the motor and pump end.

### ATTENTION

- Protect the pump against damage when transporting.
- Pump may not be placed on its pump end!
- Do not use the pump shaft for connecting any transportation aids such as hooks or straps.



### WARNING

#### Risk of injury by discharging fluid!

Pumping fluid that remains inside the pump after shut down can freeze during low temperature conditions and cause damage and cracks to pump components, such as the pump body. As a result, after restart of the pump the pumping fluid can then discharge through such cracks under high pressure and cause severe injury.

- Pumps must be drained prior to their storage.
- Store pump in dry and protected areas and protect it against penetration of foreign bodies.
- Always store pump above the freezing point!

## 5 Installation and Connection

### 5.1 Mechanical installation



### WARNING

#### Risk of clamping or crushing body parts when installing or removing the pump exists!

- Pump must be secured with appropriate hoist.

- During any assembly or disassembly process the pumps must be secured against tipping through ropes for example at all times.
- The pumps must be securely mounted to the tank.



### CAUTION

#### Risk of cutting and crushing!

If the pipe work is installed under tension and with stress on the pump, the discharge port can break off and the pipe work can collapse.

- Discharge piping must be installed without tension or stress with proper support.
- Discharge piping must never be used as a step ladder.
- Do **not prop up** the pressure line via the joining socket.
- The pump must never under any circumstances be used as a point for securing the piping.
- No forces or torques from the piping may be allowed to affect the pump.
- Pipes must be intercepted directly before the pump and connected with no tension.
- Piping, tank and pumps must be mounted **without any tension**.

### ATTENTION

- Maximum tightening torque for piping connections is 170 Nm!

### ATTENTION

- When installed the space around the pump must be large enough to provide sufficient cooling of the motor.

The fluid inlet is on the face side of the flange-connected pump mechanism.

The clearance between the suction opening and the tank floor should be large enough to prevent the suction opening from becoming blocked even if the coolant is heavily polluted and the pump has not been operated for long periods.

- To obtain the full flow rate it is recommended to choose for the pipework the nominal bore diameter of the pumps cross section for connection.
- Pipe bends should be used, not pipe angles.
- The pipework must be qualified for occurring hydraulic pressure.
- The positions of the foot and pressure connection can be moved around the circumference to 3 different positions. On the S-type, the pipe connection can also be set to normal or parallel alignment to the pump axis.

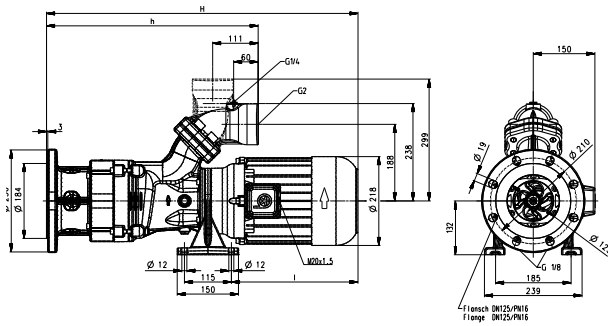

Drawing 1

**WARNING****Risk of injury by ejected parts!**

The pump may only be operated if installed within a suitable tank with proper enclosures!

- As particles and/or chips can be redirected from the pump suction at a high velocity, the tank design must incorporate appropriate protection, i.e. a tank cover, that prevents such objects from being ejected out off the tank.

**WARNING****Risk of crushing and cutting by moving parts!**

- The pump must be mounted in that way that rotating parts under the cover of the coolant tank can not be touched!

**WARNING****Risk of fire and explosion!**

The creation of an ignition spark with the presence of an ignitable aerosol can lead to risk of fire and explosion!

When pumping cooling- and cutting oils the following is to be adhered to:

- The geometry of the tank must be designed and executed in such a way that no flammable aerosol can develop (i.e. through velocity) during operation of the pump.
- The necessity of mist collection / exhaustion must be investigated and determined.
- In order to avoid the formation of an ignition spark, no foreign particles may enter the tank.

## 5.2 Electric wiring

**WARNING****Electric shock!**

All service work must be carried out by qualified service personnel. Pump must be disconnected from the power source and all rotating parts must stand still. Reassure that pump is disconnected from power source and cannot be switched on.

- Verify that there is no voltage at the terminal board!
- According to the European Standard EN809 a motor overload must be installed and properly set to the full load amps stated on the pump name plate.

**WARNING****Risk of injury by uncontrolled start-up of the pump or by missing emergency shut off switch!**

Unwanted pump start-up or missing shut off switches can cause severe injury through ejected parts from the pump discharge or from cutting or pulling body parts into the pump suction.

- Reassure that pump is disconnected from power source and cannot be switched on.
- It is the responsibility of the machine operator to decide whether or not an additional emergency switch must be installed.

**WARNING****Risk of electric shock**

Our asynchronous motors can optionally be fitted with temperature sensors in the form of triplet PTC thermistors, which are used for thermal monitoring of the motor windings. Please note that the temperature sensors meet the insulation requirements of basic insulation. The improper connection of the triplet PTC thermistors to evaluation units that do not have a protective function against overvoltage in the event of a fault can lead to voltages dangerous to the touch and electric shock.

Please check whether the evaluation units you intend to use are permissible for the electrical connection of the temperature sensors.

## 5.2.1 Circuit

### WARNING

#### Electric shock!

Tension voltage and frequency must correspond with the shown specification on the nameplate.

- The pump must be wired so that a solid longterm electrical connection is ensured.
- Establish a solid ground connection.

**The electrical wiring must be performed according to the wiring diagram shown inside the terminal box cover.**

**(Please see above sample wiring diagrams):**

Wiring diagram e.g.

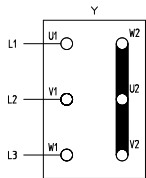

**Star connection**  
3 x 400 V, 50 Hz  
resp. 380-415 V, 50 Hz

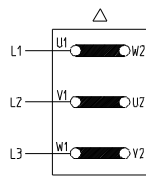

**Delta connection**  
3 x 230 V, 50 Hz  
resp. 220-240 V, 50 Hz

Drawing 2

There may be no foreign objects such as dirt, particles or humidity inside the terminal board.

- Mount terminal board cover to motor tight against dust and humidity and close up all unused wiring ports.

### ATTENTION

When Variable Frequency Drives are used interfering signals might occur.  
Non-sinus shaped supply voltage from a variable frequency drive might result in elevated motor temperatures.

## 6 Start up / Shut down

### 6.1 Start up

### ATTENTION

- After connection the electrical wires, close the terminal box. Briefly start the motor (max. 30 sec.).
- Check the rotation according to the arrow on the top of the motor.

If the direction is incorrect change over two of the power leads.

## 6.2 Shut down

### WARNING

#### Electric shock!

All service work must be carried out by qualified service personnel. Pump must be disconnected from the power source and all rotating parts must stand still. Reassure that pump is disconnected from power source and cannot be switched on.

- Verify that there is no voltage at the terminal board!
- Open terminal box and disconnect the power leads.
- Empty out the pump.

## 7 Operation



### WARNING

**Risk of injury by uncontrolled start-up of the pump or absence of emergency shutt of switch!**

Unwanted pump start-up or missing shut off switches can cause severe injury through ejected parts from the pump discharge or from cutting or pulling body parts into the pump suction.

- Reassure that pump is disconnected from power source and cannot be switched on.
- It is the responsibility of the machine operator to decide whether or not an additional emergency switch must be installed.

### Liquid level

These pumps are not self-priming and must be gravity fed.

Possible leakage must be drained away so as to prevent any risk to persons or the environment.

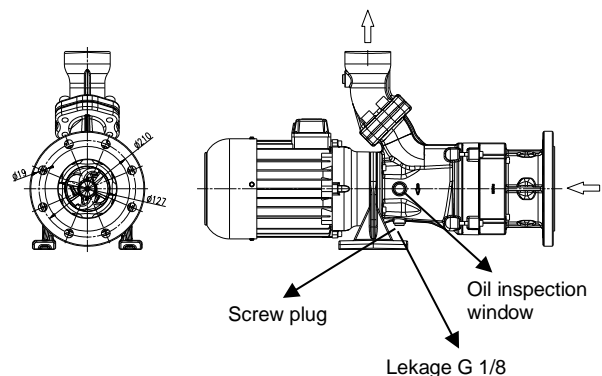

Drawing 3

**WARNING****Risk of fire and explosion!**

The creation of an ignition spark with the presence of an ignitable Aerosol can lead to risk of fire and explosion.

The fluid level must be above the suction mouth of the pump during pumping of cooling- and cutting oils in order to avoid the possibility of the creation of an ignition spark.

- Unwanted objects, such as broken tools or indexing plates which still lie under the pump after stopping the working process must be taken out in regular intervals!
- Any repair or maintenance work must be performed after the pump has been turned off and the shaft has come to a complete stop. Risk of injury!  
See provided warning label!
- If the pump should lock up and cease, shut pump down (see point 6.2) and disconnect from power supply. Pump must be uninstalled and removed from the system prior to its repair.

**ATTENTION**

Pulsed mode causes increased wear due to the return flow of chips and additional load on the bearings.

- The SBC pump should be operated in continual operation mode, **not pulsed mode!**
- The pump should transport medium without chips for 1-2 minutes before being switched off!

**8 Servicing and Maintenance****CAUTION****Risk of burns!**

- The pump must have cooled down sufficiently prior to commencing any repair, maintenance or installation.

**WARNING****Risk of injury through contaminated parts!**

- Pumps and pump units which convey hazardous media must be decontaminated.

**ATTENTION**

- The surface of the motor must be kept free of dirt.

The motor shaft is spinning in permanently greased ball bearings and does not require any special maintenance.

- On completion of work all safety and protective facilities must be re-installed and made operative again.
- Prior to restarting the machine, the instructions listed under “Start up” (point 6.1) are to be observed

**8.1 Pumps with double mechanical seal (-GD)****ATTENTION**

Pumps with double mechanical seal (-GD) are identified by the letters GLRD stamped in on the motor side of the pump foot and must include an oil receiver with a capacity of 0.45 litres. Check this through the inspection window.

Oil receiver Castrol WHITEMOR WOM14 or equivalent oil.



## 9 Trouble shooter's guide

Fault	Cause	Remedy
Motor does not start, no motor noise	At least two of the power supply leads have failed	Check fuses, terminals and supply leads.
	Overload has tripped	Inspect overload
Motor does not start, humming noise	One of the supply leads has failed	See above
	Impeller faulty Motor bearing faulty	Replace impeller Replace bearing
Overload trips	Pump locked up mechanically	Inspect pump hydraulics
	High on/of cycling frequency	Check application
Power consumption is too high	Wrong direction of rotation of impeller	See above
	Lime or other deposits mechanical friction	Clean pump mechanism repair pump
Motor overheats	High on/off cycling frequency	See above
	Wrong power supply (voltage or cycles)	Power supply must correspond with name plate rating
Pump does not pump	Insufficient cooling	Check air flow at motor fan
	liquid level too low Pump mechanism faulty Pipe blocked	Fill up liquid replace pump mechanism Clean pipe
The pump pumps no chips	Chip breaker worn or damage	Replace the chip breaker
Insufficient flow and pressure	Wrong direction of rotation of impeller	Change over two power supply leads
	Pump mechanism silted up Worn pump mechanism	Clean pump mechanism Replace pump mechanism
Incorrect flow or pressure	Wrong power supply (voltage or cycles)	Power supply must correspond with name plate rating
Running noise/Vibration	Foreign objects in pump end	Remove foreign objects
	Impeller damaged Bearing/Bushing broken	Replace impeller Replace bearing/bushing

## 10 Spare part

### 10.1 Spare part list for the Brinkmann pumps Series SBC820...1120

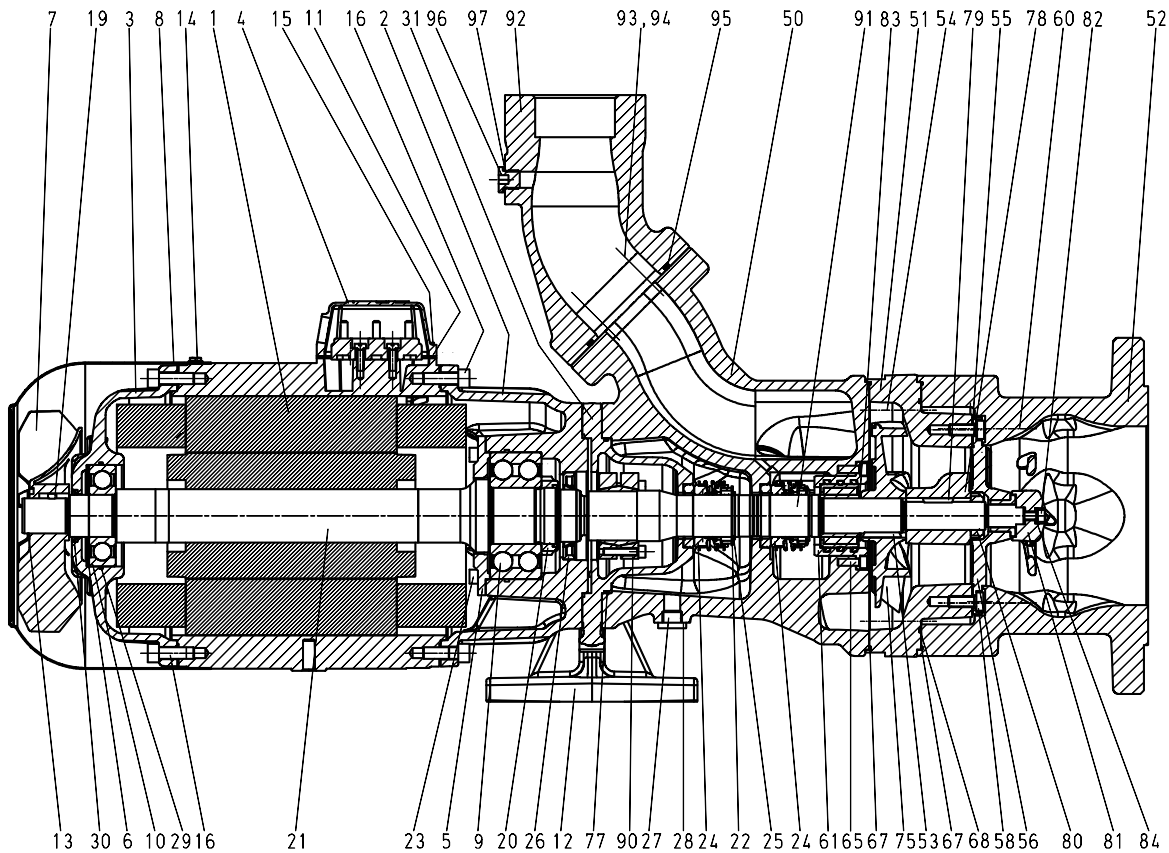

Drawing 4

#### Item Description

1	Stator with terminal board	
2	Motor flange	
3	End shield	
4	Terminal box	
5	Bearing cover	
6	Compensation disk	
7	Fan	
8	Fan cover	
9	Ball bearing	DIN 628
10	Ball bearing	DIN 625
11	Gasket	
12	Pump foot	
13	Retaining ring	
14	Spiral-shaped screw	DIN 7500
15	Socket head cap screw	DIN 84
16	Socket head cap screw with lock	DIN 912
19	Parallel pin	DIN 7
20	Shaft nut	
21	Motor shaft with rotor	
22	Shim ring	
23	Socket head cap screw	DIN 912
24	Mechanical seal	
25	Circlip	
26	Shaft seal	
27	Oil inspection window	
27	Screw plug	DIN 908
28	Sealing ring	DIN 7603
29	O-ring	
30	Shaft seal	
31	Socket head cap screw with lock	DIN 912

#### Item Description

50	Pump body	
51	Intake cover	
52	Connection cover	
53	Woodruff key	DIN 6888
54	Socket head cap screw with lock	DIN 912
55	Shim ring	
56	Chip breaker with bearing bush	
58	Socket head cap screw with lock	DIN 912
60	Socket head cap screw with lock	DIN 912
61	Bushing cartridge assembly	
65	Socket head cap screw	DIN 912
67	O-ring	
68	O-ring	
75	Impeller	
77	O-ring	
78	Suction screw	
79	Woodruff key	DIN 6888
80	Shaft nut	
81	Agitator	
82	Socket head cap screw with lock	DIN 912
83	Shim ring	
84	Serrated lock washer	
90	Shaft clamp	
91	Insert shaft	
92	Joining socket	
93	Socket head cap screw	DIN 912
94	Spring washer	DIN 7980
95	O-ring	
96	Screw plug	DIN 908
97	Sealing ring	DIN 7603

## 10.2 Indications to the spare part order

Spare parts are available from the supplier. Standard commercially available parts are to be purchased in accordance with the model type. The ordering of spare parts should contain the following details:

### 1. Pumptype

e.g. SBC1120

### 2. Pump No.

e.g. 06248082

The date of the construction year is a component of the pumps type number.

### 3. Voltage, Frequency and Power

Take item 1, 2 and 3 from the nameplate

### 4. Spare part with item No.

e.g. connection cover item No. 52

## 11 Repair Instructions / Replacing the rotary mechanical seal / the shaft clamp

### 11.1 Replacing the rotary mechanical seal



#### WARNING

**Risk of injury due to sharp edges on pump components, i.e. impeller blades!**

- Wear safety gloves!
- Disconnect the pump electrically and mechanically.
  - Note the markings on the pump components prior to dismantling.
  - When completely dismantling a unit with dual axial face seals, drain the medium in the blocking chamber through the screw plug (27).
- Loosen the socket head cap screws (60) and remove the connection cover (52).
- Loosen the Socket head cap screws (82) and remove the agitator (81) with serrated lock washer (84).
- Loosen the socket head cap screws (58) and remove the shim ring (55) and the chip breaker (56).
- Loosen the shaft nut (80) and remove the suction screw (78).
- Loosen the socket head cap screws (54) and remove the intake cover with o-ring (67).
- Use two screwdrivers to push the impeller (75) from the insert shaft (91). Insert the screwdrivers between the impeller (75) and the pump body (50).
- Remove the woodruff key (53) from the insert shaft (91). Loosen the socket head cap

- screws (65) and remove the bushing cartridge assembly (61) with the shim ring (83).
- Remove the circlip (25) and the shim ring (22).
- Remove the rotating axial face seal unit (24b-24e).
- Loosen the Socket head cap screws (31) and remove the pump body (50).
- Remove circlip (25) and shim ring (22) and remove the rotating axial face seal unit (24b-24e).
  - To replace the insert shaft, see position 11.2).
  - When changing an axial face seal, remove the stationary axial face seal unit (24a) from the pump body (50) and pump foot (12). Clean the seat of the seal and the pump parts!
- The mechanical seal (24) should now be completely replaced. If necessary replace the o-rings (67), (77) and impeller (75).
- Fit a new mechanical seal.
- The sliding surfaces of the axial face seal must be free of dirt and grease. Lightly moisten the collar (24a) with prill water and press the stationary axial face seal unit (24a) into the pump body (50) and pump foot (12).
  - Slide the rotating axial face seal unit (24b-24e) onto insert shaft (91) and fix in position using shim ring (22) and circlip (25).
- The remainder of the reassembly process is to be completed in the opposite order of the prior described dismantling process.

#### ATTENTION

Assembly help and detailed instruction is demanded for the assembly of the pump and adjusting of the cutting unit!

- Request the required documents from the manufacturer.

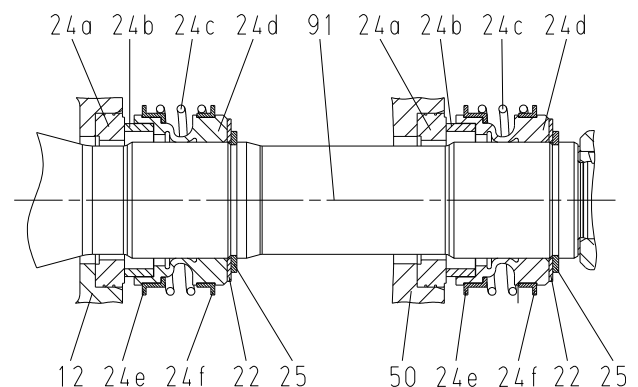

Drawing 5

## 11.2 Dismantling the insert shaft

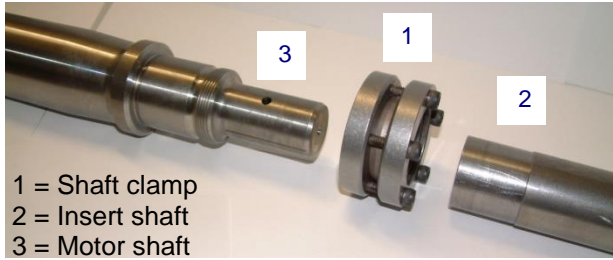

Drawing 6

- Disconnect the inline pump from the mains both electrically and mechanically.



### CAUTION

#### Risk of burns!

- The pump must have cooled down sufficiently prior to commencing any repair or maintenance.



### WARNING

#### Risk of squeezing or crushing body parts when installing or removing the pump exists!

- Secure pump with appropriate hoist.
- Remove pump from system. Secure pump against tipping over, i.e. use ropes to secure pump.
- Empty out the Pump and dismantle the pump unit.



### WARNING

#### Risk of injury due to sharp edges on pump components, i.e. impeller blades!

- Wear safety gloves!
- Dismantle the pump body and the pump foot.



### WARNING

#### Risk of injury by discharging parts!

- Do not, under any circumstances, remove the screws on the shaft clamp (1) completely.
- Loosen the screws on the shaft clamp (1).
- Remove the insert shaft (2) and shaft clamp (1) off the motor shaft (3).

## 11.3 Assembling the insert shaft and motor shaft



### WARNING

#### Risk of jamming or crushing during pump installation or removal!

- Secure pump with appropriate hoist.

### ATTENTION

- Clean the contact surfaces of the insert shaft (2) (inside) and the motor shaft (3). They must not be lubricated or oiled.
- Disassemble the fan cover and the fan from the motor. Set the pump down on the end of the shaft (a fixture must be used).
- Position the shaft clamp (1) (use a new shaft clamp) in the centre of the cranked clamping diameter (2) of the insert shaft.
- Insert the motor shaft (3) into the insert shaft (2).
- Tighten:  
Mark the first screw and tighten all the screws evenly by hand, one after the other in a clockwise direction (not cross-ways).
- Use a torque screwdriver to tighten each screw first with 2 Nm then with 3.5 Nm and finally with 5 Nm (in a clockwise direction again).
- Repeat the last turn (with 5 Nm) 3 times.



### WARNING

#### Risk of injury due to sharp edges on pump components, i.e. impeller blades!

- Wear safety gloves!
- Mount the pump foot and the pump body.
- The remainder of the reassembly process is to be completed in the opposite order of the prior described dismantling process.

**ATTENTION**

Assembly help and detailed instruction is demanded for the assembly of the pump and adjusting of the cutting unit!

- Request the required documents from the manufacturer.
- Note torques for the screw connections!

**Tightening torques for screwed connections**

Thread - Ø	M5	M6		M8	M16
<b>Strength classes</b>	8.8	8.8	12.9	8.8	8.8
<b>Tightening torque (Nm)</b>	3 Nm	4.5 Nm	16 Nm Item 82	20 Nm	60 Nm

- Position the pump laterally and fill the pump blocking chamber (-GD) with oil until it reaches the oil inspection window (27) (0.45 litres).
- Fit the sealing ring (28) and screw on the screw plug (27).
- Pump Installation. Secure pump against falling over. i.e. with use of safety straps.
- Reconnect immersion pump as described in point 5.

**ATTENTION**

- When putting the pump back into use, **make sure the direction of rotation is correct** (see point 6.1)!

**12 Disposal**

When disposing of the pump or the packaging materials the local and national regulation for proper disposal must be complied with.

- Prior to its disposal, the pump must be completely drained and decontaminated if necessary.

## 13 Declarations of conformity

### 13.1 UK declaration of conformity



#### UK declaration of conformity

Manufacturer

**Brinkmann Pumpen, K. H. Brinkmann GmbH & Co. KG**  
**Friedrichstraße 2**  
**D-58791 Werdohl**  
**Germany**

This declaration of conformity is issued under the sole responsibility of Brinkmann Pumps and belongs to the following product.

Product name

**Horizontal End-Suction Pumps**

Type                      **SBC820...1120**

The named product described above complies with the following statutory requirements of United Kingdom:

<b>UK SI 2008 No. 1597</b>	<b>The Supply of Machinery (Safety) Regulations 2008</b>
<b>UK SI 2016 No. 1091</b>	<b>The Electromagnetic Compatibility Regulations 2016</b>
<b>UK SI 2020 No. 1647</b>	<b>The Restriction of the Use of Certain Hazardous Substances in Electrical and Electronic Equipment Regulations 2020</b>

The following exceptions in accordance with table 1, "Table of exempted applications" are claimed: No.12 (6a), No.15 (6b)

The following designated standards and technical specification have been applied:

<b>EN 809:1998+A1:2009+AC:2010</b>	<b>EN ISO 12100:2010</b>	<b>EN 60204-1:2018</b>
<b>EN IEC 61000-3-2 :2019 +A1 :2021</b>	<b>EN 61000-3-3 :2013+A1 :2019 +A2 :2021 +A2 :2021/AC :2022</b>	
<b>EN IEC 61000-6-2 :2019</b>	<b>EN IEC 61000-6-3 :2021</b>	<b>EN IEC 63000 :2018</b>

Additionally the following standard has been applied:

**EN 60034-1 :2010/AC :2010**

The instructions contained in the operating manual for installation and start up the pump have to be followed.

**Brinkmann Pumpen, K. H. Brinkmann GmbH & Co. KG**

Werdohl, 06.06.2024

.....  
 Dr.-Ing. Dirk Wenderott  
 Chief Product Officer (CPO)  
 Head of Engineering

Dr. H. Abou Dayé  
 K. H. Brinkmann GmbH & Co. KG  
 Friedrichstraße 2, D-58791 Werdohl  
 Representative of documentation

## 13.2 EC declaration of conformity

DEUTSCH / ENGLISH / FRANÇAIS / ESPAÑOL



### EG-Konformitätserklärung

#### EC declaration of conformity / Déclaration de conformité CE / Declaración de conformidad CE

Hersteller / Manufacturer / Constructeur / Fabricante

**Brinkmann Pumpen, K. H. Brinkmann GmbH & Co. KG**  
**Friedrichstraße 2, D-58791 Werdohl**

Produktbezeichnung / Product name / Désignation du produit / Designación del producto

**Cutterpumpen / Horizontal End-Suction Pumps / Pompes Broyeuses / Bombas Trituradoras**

**Typ / Type / Tipo SBC820...1120**

Das bezeichnete Produkt stimmt mit den folgenden Richtlinien des Rates zur Angleichung der Rechtsvorschriften der EG-Mitgliedsstaaten überein:

The named product conforms to the following Council Directives on approximation of laws of the EEC Member States:  
Le produit sus-mentionné est conforme aux Directives du Conseil concernant le rapprochement des législations des Etats membres CEE:

El producto designado cumple con las Directivas del Consejo relativas a la aproximación de las legislaciones de los Estados Miembros de la CEE:

<b>2006/42/EG</b>	Richtlinie für Maschinen
<b>2006/42/EC</b>	Council Directive for machinery
<b>2006/42/CE</b>	Directive du Conseil pour les machines
<b>2006/42/CE</b>	Directivas del Consejo para máquinas
<b>2014/30/EU</b>	Richtlinie für elektromagnetische Verträglichkeit
<b>2014/30/EU</b>	Council Directive for Electromagnetic compatibility
<b>2014/30/UE</b>	Directive du Conseil pour Compatibilité électromagnétique
<b>2014/30/UE</b>	Directivas del Consejo para Compatibilidad electromagnética
<b>2011/65/EU und 2015/863/EU</b>	RoHS Richtlinien
<b>2011/65/EU and 2015/863/EU</b>	RoHS Directives
<b>2011/65/UE et 2015/863/UE</b>	Directives RoHS
<b>2011/65/UE y 2015/863/UE</b>	RoHS Directivas

Folgende Ausnahmen gem. Anhang III RoHS (2011/65/EU) werden in Anspruch genommen: 6a, 6b.

The following exceptions in accordance with appendix III RoHS (2011/65/ EU) are claimed: 6a, 6b.

Les exceptions suivantes selon l'annexe III RoHS (2011 / 65 / UE) sont revendiquées : 6a, 6b.

Las siguientes excepciones conforme al apéndice III RoHS (2011/65 / UE) son requeridas: 6a, 6b.

Hinsichtlich der elektrischen Gefahren wurden gemäß Anhang I Nr. 1.5.1 der Maschinenrichtlinie 2006/42/EG die Schutz-  
ziele der Niederspannungsrichtlinie 2014/35/EU eingehalten.

With respect to potential electrical hazards as stated in appendix I No. 1.5.1 of the machine guide lines 2006/42/EC all  
safety protection goals are met according to the low voltage guide lines 2014/35/EU.

Conformément à l'annexe I N° 1.5.1 de la Directive "Machines" (2006/42/CE) les objectifs de sécurité relatifs  
au matériel électrique de la Directive "Basse Tension" 2014/35/UE ont été respectés.

Con respecto al potencial peligro eléctrico como se indica en el apéndice I No. 1.5.1 del manual de la máquina  
2006/42/CE, todos los medios de protección de seguridad se encuentran según la guía de bajo voltaje 2014/35/UE.

Die Übereinstimmung mit den Vorschriften dieser Richtlinien wird nachgewiesen durch die vollständige Einhaltung  
folgender Normen:

Conformity with the requirements of this Directives is testified by complete adherence to the following standards:

La conformité aux prescriptions de ces Directives est démontrée par la conformité intégrale avec les normes suivantes:

La conformidad con las prescripciones de estas directivas queda justificada por haber cumplido totalmente las siguientes normas:

Harmonisierte Europ. Normen / Harmonised Europ. Standards / Normes europ. harmonisées / Normas europ. Armonizadas

**EN 809 :1998+A1 :2009+AC :2010    EN ISO 12100 :2010    EN 60204-1 :2018    EN IEC 61000-3-2 :2019 +A1 :2021**  
**EN 61000-3-3 :2013+A1 :2019 +A2 :2021 +A2 :2021/ZAC :2022    EN IEC 61000-6-2 :2019    EN IEC 61000-6-3 :2021**  
**EN IEC 63000 :2018**

Nationale Normen / National Standards / Normes nationales / Normas nacionales : **EN 60034-1 :2010/AC :2010**

**Die Hinweise in der Betriebsanleitung für den Einbau und die Inbetriebnahme der Pumpe sind zu beachten.**

**The instructions contained in the operating manual for installation and start up the pump have to be followed.**

**Les indications d'installation / montage et de mise en service de la pompe prévues dans l'instruction d'emploi doivent être suivies.**

**Tenga en cuenta las instrucciones en el manual para la instalación y puesta en marcha de la bomba.**

**Brinkmann Pumpen, K. H. Brinkmann GmbH & Co. KG**

Werdohl, 06.06.2024

Dr.-Ing. Dirk Wenderott  
Chief Product Officer (CPO)  
Head of Engineering

Dr. H. Abou Dayé  
K. H. Brinkmann GmbH & Co. KG  
Friedrichstraße 2, D-58791 Werdohl  
Dokumentationsbevollmächtigter / Representative of  
documentation/ Mandataire de documentation /  
Mandatario de documentación