

## BE7450 Operating Instructions (Translation of original)

---

# BRINKMANN - Miniature Centrifugal Pumps with a magnetic coupling series

## BMK3, BMK4

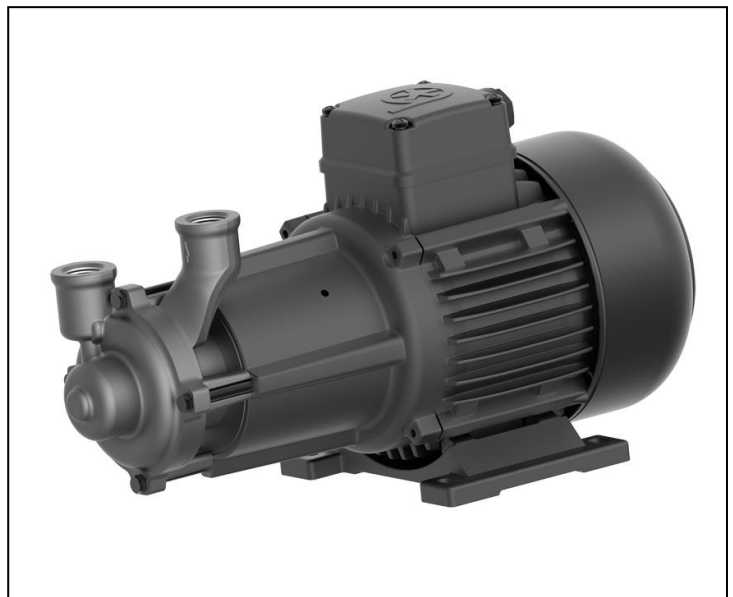

**Brinkmann Pumpen**  
**K. H. Brinkmann GmbH & Co. KG**  
Friedrichstraße 2 D-58791 Werdohl  
Tel.: +49-2392 / 5006-0  
Fax.: +49-2392 / 5006-180

[www.brinkmannpumps.de](http://www.brinkmannpumps.de)  
[sales@brinkmannpumps.de](mailto:sales@brinkmannpumps.de)

Subject to change without prior notice.

Order - No.: BE7450 ENGLISCH

# Brinkmann – Miniature Centrifugal Pumps with a magnetic coupling series BMK

## Contents

|   |                                   |   |    |                                  |   |
|---|-----------------------------------|---|----|----------------------------------|---|
| 1 | Indication to the manual .....    | 2 | 8  | Servicing and Maintenance.....   | 6 |
| 2 | Description of product .....      | 2 | 9  | Trouble shooter's guide .....    | 6 |
| 3 | Safety instructions .....         | 3 | 10 | Spare part.....                  | 7 |
| 4 | Transport and storage.....        | 4 | 11 | Disposal.....                    | 7 |
| 5 | Installation and Connection ..... | 4 | 12 | Declarations of conformity ..... | 8 |
| 6 | Start up / Shut down.....         | 5 |    |                                  |   |
| 7 | Operation.....                    | 5 |    |                                  |   |

## 1 Indication to the manual

This operating manual gives basic instructions which are to be observed during installation, operation and maintenance of the pump. It is therefore imperative that this manual be read by the responsible personnel and operator prior to assembly and commissioning. It is always to be kept available at the installation site.

### 1.1 Identification of safety instructions in the operating manual

Safety instructions given in this manual non-compliance with which would affect **safety** are identified by the following symbol



Safety sign according with ISO 3864 –B.3.1

or where **electrical safety** is involved, with:



Safety sign according with ISO 3864–B.3.6

Where **magnetic safety** is involved, with:



Risk of magnetic fields



Influence to pace makers

Where non-compliance with the safety instructions may cause a risk to the machine and it's function the word

**ATTENTION**

is inserted.

## 2 Description of product

### 2.1 General description of the pump

The miniature centrifugal pump operate according to the bypass duct principle. These pumps are not self-priming and must be gravity fed.

Pump and motor form a complete unit. The impeller is designed as peripheral impeller and is firmly arranged at the pump shaft. The pump housing is directly screwed to the motor. The pump is hermetically sealed, with a solenoid-operated clutch.

The pump is to be protected against coarse particles.

The pumps BMK are mounted next to or on top of the tank. The pumps are foot mounted and must be screwed down in order to ensure a secure stance.

### 2.2 Intended use

The pumps BMK are suitable for pumping clean water up to 160° C temperature and 7 bar system-pressure within the limiting application in accordance with table 1.

**Limit of Application (Table 1)**

| Type                            | BMK  |
|---------------------------------|--|
| Mediums                         | Industry water up to 160° C at 7 bar System-pressure |
| Temperature of medium           | ...+ 160° C  |
| min. delivery volume            | 1% of Q max.   |
| Dry running                     | The pumps are not suitable for dry running.          |
| Switching-on frequency per hour | Motors less 3 kW max. 200                            |
| Ambient temperature             | 40 °C  |
| Set-up altitude                 | 1000 m   |

### **ATTENTION**

The pumps are to be operated within their design limits. Applications outside of these limits are not approved. The manufacturer is not responsible for any damages resulting from use of the pumps in such applications.

## 2.3 Technical data

| Type | Max. del. pressure bar / spec. weight 1 | Max. del. volume l/min | Height H mm | h mm | Pipe connection | Weight kg | Power 50 / 60 Hz kW | Noise level <sup>1)</sup> dBA/50 Hz |
|------|---|------------------------|-------------|------|-----------------|-----------|---------------------|-------------------------------------|
| BMK3 | 5.2                                     | 28                     | 374         | 71   | G ½             | 10.8      | 0.63 / 0.725        | 65                                  |
| BMK4 | 5.8                                     | 55                     | 430         | 67.5 | G ¾             | 14        | 1.1 / 1.27          | 67                                  |

1) Noise emissions measured in accordance with DIN 45635 at a distance of 1 m

The motor is surface-cooled and compliant with DIN IEC 34 and EN 60034 (protection degree IP 55).

## 3 Safety instructions

When operating the pump, the safety instructions contained in this manual, the relevant national accident prevention regulations and any other service and safety instructions issued by the plant operator are to be observed.

### 3.1 Hazards in the event of non-compliance with the safety instructions

Non-compliance with the safety instructions may produce a risk to the personnel as well as to the environment and the machine and results in a loss of any right to claim damages.

For example, non-compliance may involve the following hazards:

- Failure of important functions of the machines/plant
- Failure of specified procedures of maintenance and repair
- Exposure of people to electrical, mechanical and chemical hazards
- Endangering the environment due to hazardous substances being released

### 3.2 Unauthorized modes of operation



- Pump may not be used in potentially explosive environments!
- Pump and discharge piping are not designed to hold any weight and may not be used as a step ladder.

### 3.3 Remaining Risk



#### Risk of Injury!

Risk of squeezing or crushing body parts when installing or removing the pump exists. Proper and secured lifting tools must be used.

#### Risk of burns!

The pump must have cooled down sufficiently prior to commencing any repair, maintenance or installation.

### 3.4 Qualification and training of operating personnel

The personnel responsible for operation, maintenance, inspection and assembly must be adequately qualified. Scope of responsibility and supervision of the personnel must be exactly defined by the plant operator. If the staff does not have the necessary knowledge, they must be trained and instructed, which may be performed by the machine manufacturer or supplier on behalf of the plant operator. Moreover, the plant operator is to make sure that the contents of the operating manual are fully understood by the personnel.

### 3.5 Safety instructions relevant for operation

- If hot or cold machine components involve hazards, they must be guarded against accidental contact.
- Guards for moving parts (e.g. coupling) must not be removed from the machine while in operation.
- Any leakage of hazardous (e.g. explosive, toxic, hot) fluids (e.g. from the shaft seal) must be drained away so as to prevent any risk to persons or the environment. Statutory regulations are to be complied with.
- Hazards resulting from electricity are to be prevented (see for example, the VDE Specifications and the bye-laws of the local power supply utilities).
- The pumps are only secured safely if properly attached to the floor or top of the tank.

### 3.6 Safety instructions relevant for maintenance, inspection and assembly work

Any work on the machine shall only be performed when it is at a standstill, it being imperative that the procedure for shutting down the machine described in this manual be followed.

Pumps and pump units which convey hazardous media must be decontaminated.

On completion of work all safety and protective facilities must be re-installed and made operative again.

Prior to restarting the machine, the instructions listed under "Start up" are to be observed.

### 3.7 Signs on the pump

It is imperative that signs affixed to the machine, e.g.:

- arrow indicating the direction of rotation
- symbols indicating fluid connections be observed and kept legible.

### 3.8 Unauthorized alterations and production of spare parts

Any modification may be made to the machine only after consultation with the manufacturer. Using spare parts and accessories authorized by the manufacturer is in the interest of safety. Use of other parts may exempt the manufacturer from any liability.

## 4 Transport and storage

Protect the pump against damage when transporting.

Pumps must be drained prior to their storage.

Store pump in dry and protected areas and protect it against penetration of foreign bodies.

Always store pump above the freezing point!

## 5 Installation and Connection

### 5.1 Mechanical installation

The pumps can be mounted horizontally or vertically. Be sure that the pipe connections are on the top in the case of horizontal installation. For vertical installation the pump unit must be lower than the motor.

Pumps must be mounted securely. Piping, tank and pumps must be mounted without any tension.

The suction and pressure connections are marked with arrows of the pump body.

To obtain the full flow rate it is recommended to choose for the pipework the nominal bore diameter of the pumps cross section for connection. Therefore pipe bends should be used, not pipe angles!

The pipework must be qualified for occurring hydraulic pressure.

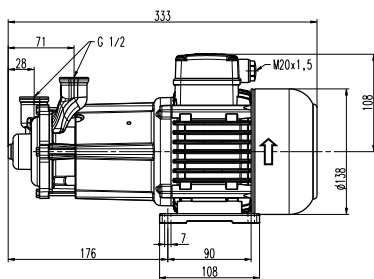

BMK3

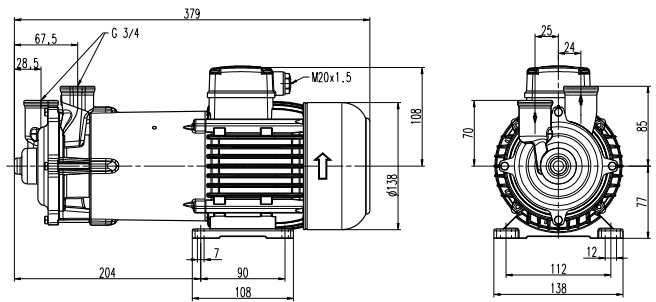

BMK4

### ATTENTION

Pay attention of the max. tightening torque for piping connection!

| Type | Pipe connection | CrNi-steel |
|------|-----------------|------------|
| BMK3 | G ½             | 140 Nm     |
| BMK4 | G ¾             | 160 Nm     |

When installed the space around the pump must be large enough to provide sufficient cooling of the motor.

Do not prop up the pressure line via the joining socket.



Start up the pump only if it is connected to the tank or to the piping!



Make sure to pay attention to permanently magnetic parts (e.g. bank cards, diskettes) when dealing with solenoid-coupled pumps because of the risk of magnetic fields)



Caution – Danger of death: Influence to pace makers. Stay away!

### 5.2 Electric wiring



All service work must be carried out by qualified service personnel. Pump must be disconnected from the power source and all rotating parts must stand still. Reassure that pump is disconnected from power source and cannot be switched on. Verify that there is no voltage at the terminal board!

According to the European Standard EN809 a motor overload must be installed and properly set to the full load amps stated on the pump name plate.

It is the responsibility of the machine operator to decide whether or not an additional emergency switch must be installed.



**Danger!**

**Risk of electric shock**

Our asynchronous motors can optionally be fitted with temperature sensors in the form of triplet PTC thermistors, which are used for thermal monitoring of the motor windings. Please note that the temperature sensors meet the insulation requirements of basic insulation. The improper connection of the triplet PTC thermistors to evaluation units that do not have a protective function against overvoltage in the event of a fault can lead to voltages dangerous to the touch and electric shock.

Please check whether the evaluation units you intend to use are permissible for the electrical connection of the temperature sensors.

**5.2.1 Circuit**



Tension voltage and frequency must correspond with the shown specification on the nameplate.

The pump must be wired so that a solid long term electrical connection is ensured. Establish a solid ground connection.

**The electrical wiring must be performed according to the wiring diagram shown inside the terminal box cover. (Please see above sample wiring diagrams):**

**Wiring diagram e.g.**

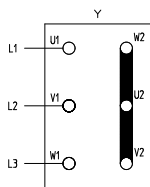

**Star connection**  
3 x 400 V, 50 Hz  
resp. 380-415 V, 50 Hz

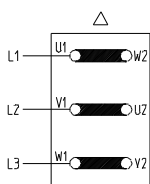

**Delta connection**  
3 x 230 V, 50 Hz  
resp. 220-240 V, 50 Hz

There may be no foreign objects such as dirt, particles or humidity inside the terminal board.

Mount terminal board cover to motor tight against dust and humidity and close up all unused wiring ports.

**ATTENTION**

When Variable Frequency Drives are used interfering signals might occur.

Non-sinus shaped supply voltage from a variable frequency drive might result in elevated motor temperatures.

**6 Start up / Shut down**

**6.1 Start up**

**ATTENTION**

Switch off at the mains.

After connection the electrical wires, close the terminal box. Briefly start the motor (max. 30 sec.) and check the rotation according to the arrow on the top of the motor.

If the direction is incorrect change over two of the power leads.

**6.2 Shut down**

All service work must be carried out by qualified service personnel. Pump must be disconnected from the power source and all rotating parts must stand still. Reassure that pump is disconnected from power source and cannot be switched on. Verify that there is no voltage at the terminal board! Open terminal box and disconnect the power leads. Empty out the pump.

**7 Operation**

**Liquid level**

These pumps are not self-priming and must be gravity fed.

Pump must be protected from contamination.

**ATTENTION**

**Recommended operation: The suction-side system pressure must have a vapour pressure distance of  $\Delta T = 10^\circ \text{C}$  (see diagram).**

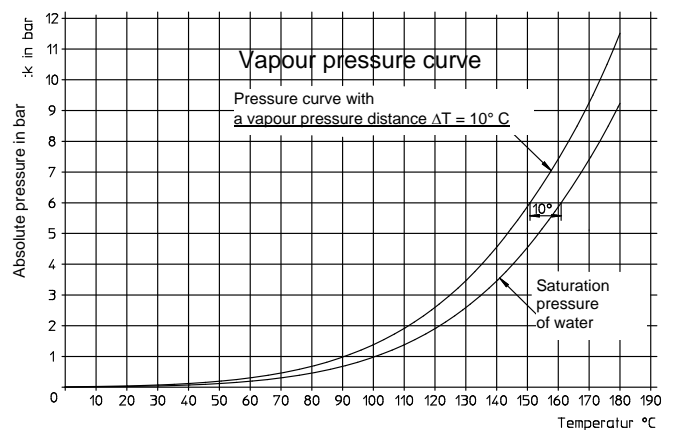

Example: Operating temperature  $T = 120^\circ \text{C}$   
 Saturation pressure  $P_{D,120^\circ \text{C}} = 1.98 \text{ bar}$   
 Recommended system pressure  $P_{\Delta T,120^\circ \text{C}} = 2.7 \text{ bar}$   
 (Absolute pressure 2.7 bar  $\cong$  manometric pressure 1.7 bar)



If the pump should lock up and cease, shut pump down (see 6.2) and disconnect from power supply. Pump must be uninstalled and removed from the system prior to its repair.

## 8 Servicing and Maintenance

### ATTENTION

The surface of the motor must be kept free of dirt.

The motor shaft is spinning in permanently greased ball bearings (with special grease and increased bearing play) and does not require any special maintenance.

## 9 Trouble shooter's guide

| Fault                                | Cause   | Remedy   |
|--------------------------------------|---|--|
| Motor does not start, no motor noise | At least two of the power supply leads have failed                      | Check fuses, terminals and supply leads                          |
|                                      | Overload has tripped  | Inspect overload   |
| Motor does not start, humming noise  | One of the supply leads has failed                                      | See above  |
|                                      | Impeller faulty<br>Motor bearing faulty                                 | Replace impeller<br>Replace bearing                              |
| Overload trips                       | Pump locked up mechanically   | Inspect pump hydraulics  |
|                                      | High on/of cycling frequency  | Check application  |
| Power consumption is too high        | Wrong direction of rotation of impeller                                 | See above  |
|                                      | Lime or other deposits<br>mechanical friction                           | Clean pump mechanism<br>repair pump                              |
| Motor overheats                      | High on/off cycling frequency<br>Wrong power supply (voltage or cycles) | See above<br>Power supply must correspond with name plate rating |
|                                      | Insufficient cooling  | Check air flow at motor fan                                      |
| Pump does not pump                   | Pump is empty   | Fill up the pump   |
|                                      | Pump mechanism faulty   | replace pump mechanism   |
|                                      | Pipe blocked  | Clean pipe   |
|                                      | Stall of magnetic forces  | Pump is obstructed. Remove blockage and restart                  |
| Insufficient flow and pressure       | Wrong direction of rotation of impeller                                 | Change over two power supply leads                               |
|                                      | Pump mechanism silted up  | Clean pump mechanism   |
|                                      | Worn pump mechanism   | Replace pump mechanism   |
|                                      | Cavitation  | Increase primary pressure (see diagram).                         |
| Incorrect flow or pressure           | Wrong power supply (voltage or cycles)                                  | Power supply must correspond with name plate rating              |
| Running noise / Vibration            | Foreign objects in pump end   | Remove foreign objects   |
|                                      | Impeller damaged  | Replace impeller   |
|                                      | Bearing/Bushing broken  | Replace bearing/bushing  |

## 10 Spare part

### 10.1 Spare part list for the miniature centrifugal pumps series BMK3, BMK4

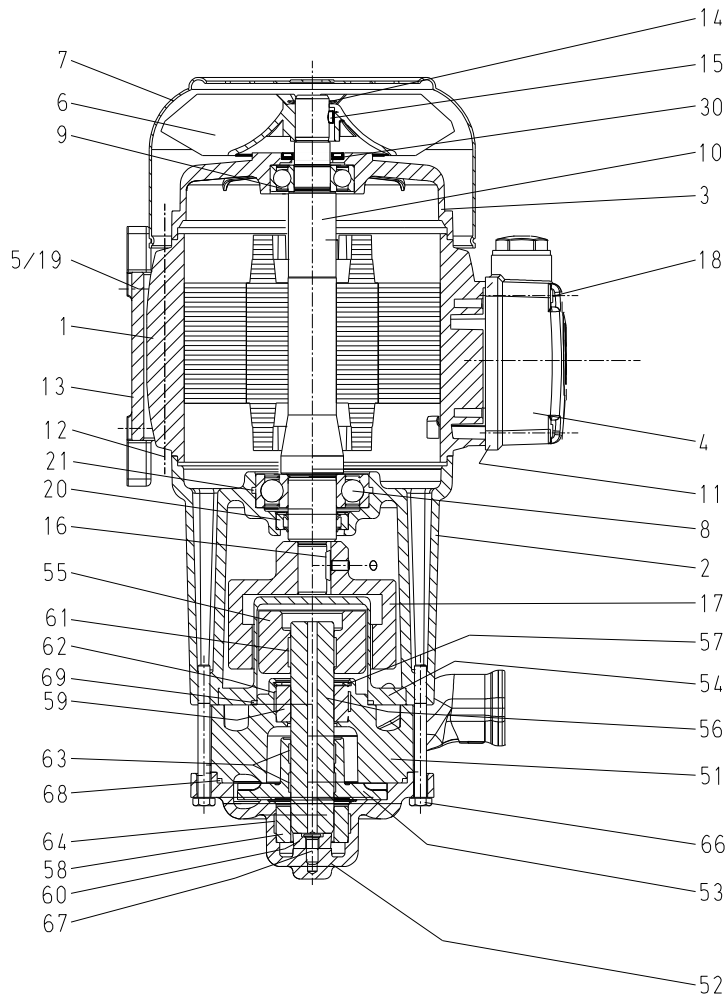

| Item | Description                |          |
|------|----------------------------|----------|
| 1    | Stator with terminal board |          |
| 2    | Flange housing             |          |
| 3    | End shield                 |          |
| 4    | Terminal box               |          |
| 5    | Socket head cap screw      | DIN 912  |
| 6    | Fan                        |          |
| 7    | Fan cover                  |          |
| 8    | Ball bearing               | DIN 625  |
| 9    | Ball bearing               | DIN 625  |
| 10   | Shaft with rotor           |          |
| 11   | Gasket                     |          |
| 12   | Stud bolt with bond        |          |
| 13   | Stator base                |          |
| 14   | Retaining ring             |          |
| 15   | Parallel pin               | DIN 7    |
| 16   | Woodruff key               | DIN 6888 |
| 17   | External rotor             |          |
| 18   | Socket head cap screw      | DIN 84   |
| 19   | Spring washer              | DIN 127  |
| 20   | Shaft seal                 |          |
| 21   | O-ring                     |          |
| 30   | Shaft seal 1.1 kW          |          |
| 51   | Pump body                  |          |
| 52   | Connection cover           |          |
| 53   | Impeller                   |          |
| 54   | Split-case                 |          |
| 55   | Internal rotor             |          |
| 56   | Shaft                      |          |
| 57   | Locking ring               | DIN 472  |
| 58   | Bearing bush               |          |
| 59   | Bearing bush               |          |
| 60   | Supporting ring            |          |
| 61   | Tolerance ring             |          |
| 62   | Tolerance ring             |          |
| 63   | Tolerance ring             |          |
| 64   | Tolerance ring             |          |
| 66   | Hexagon head cap screw     | DIN 931  |
| 67   | Torx screw                 |          |
| 68   | Sealing ring               |          |
| 69   | Sealing ring               |          |

### 10.2 Indications to the spare part order

Spare parts are available from the supplier. Standard commercially available parts are to be purchased in accordance with the model type. The ordering of spare parts should contain the following details:

- 1. Pumptype**  
e.g. BMK3
- 2. Pump No.**  
e.g. 06247450  
The date of the construction year is a component of the pumps type number.
- 3. Voltage, Frequency and Power**  
Take item 1, 2 and 3 from the nameplate
- 4. Spare part with item No.**  
e.g. Impeller item No. 53

### Tightening torques for screwed connections

| Thread - Ø             | M5               |                 |
|------------------------|------------------|-----------------|
|                        | Strength classes | 4.8             |
| Tightening torque (Nm) | 2 Nm<br>Item 12  | 5 Nm<br>Item 66 |

### 11 Disposal

When disposing of the pump or the packaging materials the local and national regulation for proper disposal must be complied with. Prior to its disposal, the pump must be completely drained and decontaminated if necessary.

## 12 Declarations of conformity

### 12.1 UK declaration of conformity



## UK declaration of conformity

Manufacturer

**Brinkmann Pumpen, K. H. Brinkmann GmbH & Co. KG**  
Friedrichstraße 2  
D-58791 Werdohl  
Germany

This declaration of conformity is issued under the sole responsibility of Brinkmann Pumps and belongs to the following product.

Product name

**Miniature Centrifugal Pumps**

Type **BMK3 ... BMK4**

The named product described above complies with the following statutory requirements of United Kingdom:

**UK SI 2008 No. 1597 The Supply of Machinery (Safety) Regulations 2008**

**UK SI 2016 No. 1091 The Electromagnetic Compatibility Regulations 2016**

**UK SI 2020 No. 1647 The Restriction of the Use of Certain Hazardous Substances in Electrical and Electronic Equipment Regulations 2020**

**The following exceptions in accordance with table 1, "Table of exempted applications" are claimed: No.12 (6a), No.15 (6b)**

The following designated standards and technical specification have been applied:

**EN 809:1998+A1:2009+AC:2010**

**EN ISO 12100:2010**

**EN 60204-1:2018**

**EN IEC 61000-3-2 :2019 +A1 :2021**

**EN 61000-3-3 :2013+A1 :2019 +A2 :2021 +A2 :2021/AC :2022**

**EN IEC 61000-6-2 :2019**

**EN IEC 61000-6-3 :2021**

**EN IEC 63000 :2018**

Additionally the following standard has been applied:

**EN 60034-1 :2010/AC :2010**

**The instructions contained in the operating manual for installation and start up the pump have to be followed.**

**Brinkmann Pumpen, K. H. Brinkmann GmbH & Co.  
KG**

Werdohl, 05.06.2024

.....  
Dr.-Ing. Dirk Wenderott  
Chief Product Officer (CPO)  
Head of Engineering

Dr. H. Abou Dayé  
K. H. Brinkmann GmbH & Co. KG  
Friedrichstraße 2, D-58791 Werdohl  
Representative of documentation



## 12.2 EC declaration of conformity

DEUTSCH / ENGLISH / FRANÇAIS / ESPAÑOL



### EG-Konformitätserklärung

#### EC declaration of conformity / Déclaration de conformité CE / Declaración de conformidad CE

Hersteller / Manufacturer / Constructeur / Fabricante

**Brinkmann Pumpen, K. H. Brinkmann GmbH & Co. KG**  
Friedrichstraße 2, D-58791 Werdohl

Produktbezeichnung / Product name / Désignation du produit / Designación del producto

**Kleinkreiselpumpen / Miniature Centrifugal Pumps / Petites pompes centrifuges / Bombas centrifugas**  
**Typ / Type / Tipo BMK3 ... BMK4**

Das bezeichnete Produkt stimmt mit den folgenden Richtlinien des Rates zur Angleichung der Rechtsvorschriften der EG-Mitgliedsstaaten überein:

The named product conforms to the following Council Directives on approximation of laws of the EEC Member States:  
Le produit sus-mentionné est conforme aux Directives du Conseil concernant le rapprochement des législations des Etats membres CEE:

El producto designado cumple con las Directivas del Consejo relativas a la aproximación de las legislaciones de los Estados Miembros de la CEE:

|                   |   |
|-------------------|---|
| <b>2006/42/EG</b> | Richtlinie für Maschinen                                    |
| <b>2006/42/EC</b> | Council Directive for machinery                             |
| <b>2006/42/CE</b> | Directive du Conseil pour les machines                      |
| <b>2006/42/CE</b> | Directivas del Consejo para máquinas                        |
| <b>2014/30/EU</b> | Richtlinie für elektromagnetische Verträglichkeit           |
| <b>2014/30/EU</b> | Council Directive for Electromagnetic compatibility         |
| <b>2014/30/UE</b> | Directive du Conseil pour Compatibilité électromagnétique   |
| <b>2014/30/UE</b> | Directivas del Consejo para Compatibilidad electromagnética |

|                                   |                  |
|-----------------------------------|------------------|
| <b>2011/65/EU und 2015/863/EU</b> | RoHS Richtlinien |
| <b>2011/65/EU and 2015/863/EU</b> | RoHS Directives  |
| <b>2011/65/UE et 2015/863/UE</b>  | Directives RoHS  |
| <b>2011/65/UE y 2015/863/UE</b>   | RoHS Directivas  |

Folgende Ausnahmen gem. Anhang III RoHS (2011/65/EU) werden in Anspruch genommen: 6a, 6b.

The following exceptions in accordance with appendix III RoHS (2011/65/ EU) are claimed: 6a, 6b.

Les exceptions suivantes selon l'annexe III RoHS (2011 / 65 / UE) sont revendiquées : 6a, 6b.

Las siguientes excepciones conforme al apéndice III RoHS (2011/65 / UE) son requeridas: 6a, 6b.

Hinsichtlich der elektrischen Gefahren wurden gemäß Anhang I Nr. 1.5.1 der Maschinenrichtlinie 2006/42/EG die Schutzziele der Niederspannungsrichtlinie 2014/35/EU eingehalten.

With respect to potential electrical hazards as stated in appendix I No. 1.5.1 of the machine guide lines 2006/42/EC all safety protection goals are met according to the low voltage guide lines 2014/35/EU.

Conformément à l'annexe I N° 1.5.1 de la Directive "Machines" (2006/42/CE) les objectifs de sécurité relatifs au matériel électrique de la Directive "Basse Tension" 2014/35/UE ont été respectés.

Con respecto al potencial peligro eléctrico como se indica en el apéndice I No. 1.5.1 del manual de la máquina 2006/42/CE, todos los medios de protección de seguridad se encuentran según la guía de bajo voltaje 2014/35/UE.

Die Übereinstimmung mit den Vorschriften dieser Richtlinien wird nachgewiesen durch die vollständige Einhaltung folgender Normen:

Conformity with the requirements of this Directives is testified by complete adherence to the following standards:

La conformité aux prescriptions de ces Directives est démontrée par la conformité intégrale avec les normes suivantes:

La conformidad con las prescripciones de estas directivas queda justificada por haber cumplido totalmente las siguientes normas:

Harmonisierte Europ. Normen / Harmonised Europ. Standards / Normes europ. harmonisées / Normas europ. Armonizadas

**EN 809 :1998+A1 :2009+AC :2010    EN ISO 12100 :2010    EN 60204-1 :2018    EN IEC 61000-3-2 :2019 +A1 :2021**  
**EN 61000-3-3 :2013+A1 :2019 +A2 :2021 +A2 :2021/ZAC :2022    EN IEC 61000-6-2 :2019    EN IEC 61000-6-3 :2021**  
**EN IEC 63000 :2018**

Nationale Normen / National Standards / Normes nationales / Normas nacionales : **EN 60034-1 :2010/AC :2010**

**Die Hinweise in der Betriebsanleitung für den Einbau und die Inbetriebnahme der Pumpe sind zu beachten.**

**The instructions contained in the operating manual for installation and start up the pump have to be followed.**

**Les indications d'installation / montage et de mise en service de la pompe prévues dans l'instruction d'emploi doivent être suivies.**

**Tenga en cuenta las instrucciones en el manual para la instalación y puesta en marcha de la bomba.**

**Brinkmann Pumpen, K. H. Brinkmann GmbH & Co. KG**

Werdohl, 05.06.2024

Dr.-Ing. Dirk Wenderott  
Chief Product Officer (CPO)  
Head of Engineering

Dr. H. Abou Dayé

K. H. Brinkmann GmbH & Co. KG  
Friedrichstraße 2, D-58791 Werdohl

Dokumentationsbevollmächtigter / Representative of  
documentation/ Mandataire de documentation /  
Mandatario de documentación