

BE7400 Operating Instructions

(Translation of original)

BRINKMANN-Miniature Centrifugal Pumps Series B401...B501



Brinkmann Pumpen
K. H. Brinkmann GmbH & Co. KG
Friedrichstraße 2 D-58791 Werdohl
Tel.: +49-2392 / 5006-0
Fax.: +49-2392 / 5006-180

www.brinkmannpumps.de
sales@brinkmannpumps.de

Subject to change without prior notice.

Order - No. : BE7400 ENGLISH

Brinkmann-Miniature Centrifugal Pumps Series B401 ... B501

Contents

1	Indication to the manual	2	9	Trouble shooter's guide.....	6
2	Description of product	2	10	Spare part	7
3	Safety instructions	3	11	Repair	8
4	Transport and storage	4	12	Disposal	8
5	Installation and Connection	4	13	Declarations of conformity.....	9
6	Start up / Shut down.....	5			
7	Operation.....	5			
8	Servicing and Maintenance	5			

1 Indication to the manual

This operating manual gives basic instructions which are to be observed during installation, operation and maintenance of the pump. It is therefore imperative that this manual be read by the responsible personnel and operator prior to assembly and commissioning. It is always to be kept available at the installation site.

1.1 Identification of safety instructions in the operating manual

Safety instructions given in this manual non-compliance with which would affect **safety** are identified by the following symbol



Safety sign according with ISO 3864 – B.3.1

or where **electrical safety** is involved, with:



Safety sign according with ISO 3864 – B.3.6

Where non-compliance with the safety instructions may cause a risk to the machine and it's function the word

ATTENTION

is inserted.

2 Description of product

2.1 General description of the pump

The miniature centrifugal pump operate according to the bypass duct principle. These pumps are not self-priming and must be gravity fed.

Pump and motor form a complete unit. The impeller is fixed on the driving shaft extension. The shaft sealing is effected with a rotary mechanical seal. The sealing for the case is effected with O-ring. The pump is to be protected against coarse particles.

The pumps B (Base-mounted Version -F) are mounted next to or on top of the tank. The pumps are foot mounted and must be screwed down in order to ensure a secure stance.

Vertically mounted pumps B (Immersion Version /110) are equipped with a mounting flange. The pump end immerses into the tank and the motor extends vertically above the tank.

2.2 Intended use

The pumps B are suitable for pumping clean water up to 140° C temperature and 5 bar system-pressure within the limiting application in accordance with table 1.

Limit of Application (Table 1)

Type	B401...B501
Mediums	Industry water up to 140° C at 5 bar system-pressure
Temperature of medium	... + 140° C
min. delivery volume	1% of Q max.
Dry running	The pumps are not suitable for dry running.
Switching-on frequency per hour	Motors less 3 kW max. 200
Ambient temperature	40 °C
Set-up altitude	1000 m

ATTENTION

The pumps are to be operated within their design limits. Applications outside of these limits are not approved. The manufacturer is not responsible for any damages resulting from use of the pumps in such applications.

2.3 Technical data

Type	Max. del. pressure bar / spec. weight 1	Max. del. volume l/min	Height H mm	h mm	Weight kg	Power 50 / 60 Hz kW	Noise level ¹⁾ dBA / 50 Hz
B401/110 B401-F	4	40	271 338	110 67	10.2 10.5	0.63	65
B501/110 B501-F	5.8	40	271 341	110 67	11.0 11.8	0.92 / 1.06	65

1) Noise emissions measured in accordance with DIN 45635 at a distance of 1 m

The motor is surface-cooled and compliant with DIN IEC 34 and EN 60034 (protection degree IP 55).

3 Safety instructions

When operating the pump, the safety instructions contained in this manual, the relevant national accident prevention regulations and any other service and safety instructions issued by the plant operator are to be observed.

3.1 Hazards in the event of non-compliance with the safety instructions

Non-compliance with the safety instructions may produce a risk to the personnel as well as to the environment and the machine and results in a loss of any right to claim damages.

For example, non-compliance may involve the following hazards:

- Failure of important functions of the machines/plant
- Failure of specified procedures of maintenance and repair
- Exposure of people to electrical, mechanical and chemical hazards
- Endangering the environment due to hazardous substances being released

3.2 Unauthorized modes of operation



- Pump may not be used in potentially explosive environments!
- Pump and discharge piping are not designed to hold any weight and may not be used as a step ladder.

3.3 Remaining Risk



Risk of Injury!

Risk of squeezing or crushing body parts when installing or removing the pump exists. Proper and secured lifting tools must be used.

Risk of burns!

The pump must have cooled down sufficiently prior to commencing any repair, maintenance or installation.

3.4 Qualification and training of operating personnel

The personnel responsible for operation, maintenance, inspection and assembly must be adequately qualified. Scope of responsibility and supervision of the personnel must be exactly defined by the plant operator. If the staff does not have the necessary knowledge, they must be trained and instructed, which may be performed by the machine manufacturer or supplier on behalf of the plant operator. Moreover, the plant operator is to make sure that the contents of the operating manual are fully understood by the personnel.

3.5 Safety instructions relevant for operation

- If hot or cold machine components involve hazards, they must be guarded against accidental contact.
- Guards for moving parts (e.g. coupling) must not be removed from the machine while in operation.
- Any leakage of hazardous (e.g. explosive, toxic, hot) fluids (e.g. from the shaft seal) must be drained away so as to prevent any risk to persons or the environment. Statutory regulations are to be complied with.
- Hazards resulting from electricity are to be prevented (see for example, the VDE Specifications and the bye-laws of the local power supply utilities).
- The pumps are only secured safely if properly attached to the floor or top of the tank.

3.6 Safety instructions relevant for maintenance, inspection and assembly work

Any work on the machine shall only be performed when it is at a standstill, it being imperative that the procedure for shutting down the machine described in this manual be followed.

Pumps and pump units which convey hazardous media must be decontaminated.

On completion of work all safety and protective facilities must be re-installed and made operative again.

Prior to restarting the machine, the instructions listed under "Start up" are to be observed.

3.7 Signs on the pump

It is imperative that signs affixed to the machine, e.g.:

- arrow indicating the direction of rotation
- symbols indicating fluid connections be observed and kept legible.

3.8 Unauthorized alterations and production of spare parts

Any modification may be made to the machine only after consultation with the manufacturer. Using spare parts and accessories authorized by the manufacturer is in the interest of safety. Use of other parts may exempt the manufacturer from any liability.

4 Transport and storage

Protect the pump against damage when transporting.

Pumps must be drained prior to their storage.

Store pump in dry and protected areas and protect it against penetration of foreign bodies.

Always store pump above the freezing point!

5 Installation and Connection

5.1 Mechanical installation

The pumps can be mounted horizontally or vertically. Be sure that the pipe connections are on the top in the case of horizontal installation. For vertical installation the pump unit must be lower than the motor.

Pumps must be mounted securely. Piping, tank and pumps must be mounted without any tension.

The suction and pressure connections are marked with arrows of the pump body.

The inlet is at the bottom of the immersed pump body (Immersion Version).

To obtain the full flow rate it is recommended to choose for the pipework the nominal bore diameter of the pumps cross section for connection. Therefore pipe bends should be used, not pipe angles!

The pipework must be qualified for occurring hydraulic pressure.

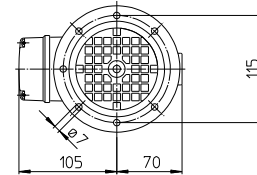
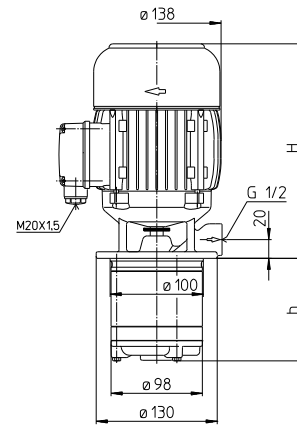

B401...B501 Immersion Version /110

ATTENTION

Pay attention of the max. tightening torque for piping connection

Type	Pipe connection	bronze
B401...B501	G 1/2	35 Nm

When installed the space around the pump must be large enough to provide sufficient cooling of the motor.

Do not prop up the pressure line via the joining socket.



Start up the pump only if it is connected to the tank or to the piping!

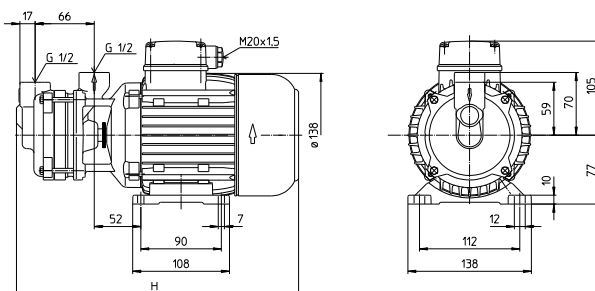

B401...B501 Base –mounted Version -F

5.2 Electric wiring



All service work must be carried out by qualified service personnel. Pump must be disconnected from the power source and all rotating parts must stand still. Reassure that pump is disconnected from power source and cannot be switched on. Verify that there is no voltage at the terminal board!

According to the European Standard EN809 a motor overload must be installed and properly set to the full load amps stated on the pump name plate.

It is the responsibility of the machine operator to decide whether or not an additional emergency switch must be installed.



Danger!

Risk of electric shock

Our asynchronous motors can optionally be fitted with temperature sensors in the form of triplet PTC thermistors, which are used for thermal monitoring of the motor windings. Please note that the temperature sensors meet the insulation requirements of basic insulation. The improper connection of the triplet PTC thermistors to evaluation units that do not have a protective function against overvoltage in the event of a fault can lead to voltages dangerous to the touch and electric shock.

Please check whether the evaluation units you intend to use are permissible for the electrical connection of the temperature sensors.

5.2.1 Circuit



Tension voltage and frequency must correspond with the shown specification on the nameplate.

The pump must be wired so that a solid long term electrical connection is ensured. Establish a solid ground connection.

The electrical wiring must be performed according to the wiring diagram shown inside the terminal box cover. (Please see above sample wiring diagrams)

Wiring diagram e.g.

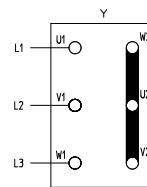

Star connection
3 x 400 V, 50 Hz
resp. 380-415 V, 50 Hz

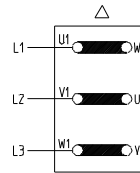

Delta connection
3 x 230 V, 50 Hz
resp. 220-240 V, 50 Hz

There may be no foreign objects such as dirt, particles or humidity inside the terminal board.

Mount terminal board cover to motor tight against dust and humidity and close up all unused wiring ports.

ATTENTION

When Variable Frequency Drives are used interfering signals might occur.

Non-sinus shaped supply voltage from a variable frequency drive might result in elevated motor temperatures.

6 Start up / Shut down

6.1 Start up

ATTENTION

Switch off at the mains.

After connection the electrical wires, close the terminal box. Briefly start the motor (max. 30 sec.) and check the rotation according to the arrow on the top of the motor.

If the direction is incorrect change over two of the power leads.

6.2 Shut down

All service work must be carried out by qualified service personnel. Pump must be disconnected from the power source and all rotating parts must stand still. Reassure that pump is disconnected from power source and cannot be switched on. Verify that there is no voltage at the terminal board! Open terminal box and disconnect the power leads. Empty out the pump.

7 Operation

Liquid level

These pumps are not self-priming and must be gravity fed.

For vertical installation (Immersion Version) the min. liquid level must reach the lower impeller.

Pump must be protected from contamination.

ATTENTION

To avoid overheating of the ball bearing, the temperature of the medium to be pumped shall be reduced to 80°C prior to pump deactivation!

Recommended operation: The suction-side system pressure must have a vapour pressure distance of $\Delta T = 10^\circ \text{C}$ (see diagram).

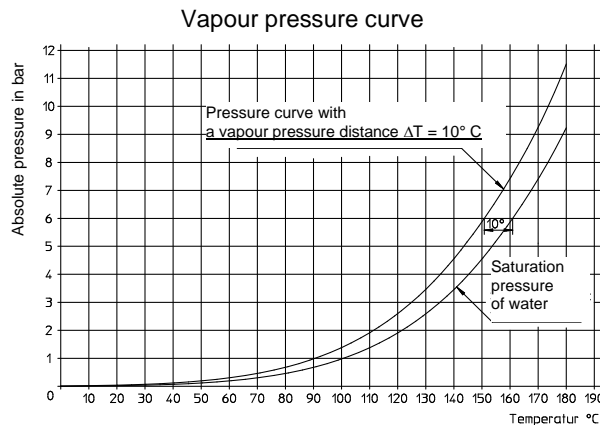

Example: Operating temperature $T = 120^\circ \text{C}$
Saturation pressure $P_{D,120^\circ \text{C}} = 1.98 \text{ bar}$
Recommended system pressure $P_{\Delta T,120^\circ \text{C}} = 2.7 \text{ bar}$
(Absolute pressure 2.7 bar \equiv manometric pressure 1.7 bar)



If the pump should lock up and cease, shut pump down (see 6.2) and disconnect from power supply. Pump must be uninstalled and removed from the system prior to its repair.



Attention! Potential Risk of Burning!

Surface temperatures above 50°C do occur during regular operation of the single-phase pumps, i.e. on the surfaces of the motor.

It must be insured that the pump has cooled down sufficiently prior to performing any repair or maintenance work.

See warning label!

8 Servicing and Maintenance

ATTENTION

The surface of the motor must be kept free of dirt.

The motor shaft is spinning in permanently greased ball bearings (with special grease and increased bearing play) and does not require any special maintenance

9 Trouble shooter's guide

Fault	Cause	Remedy
Motor does not start, no motor noise	At least two of the power supply leads have failed	Check fuses, terminals and supply leads
	Overload has tripped	Inspect overload
Motor does not start, humming noise	One of the supply leads has failed	See above
	Impeller faulty Motor bearing faulty	Replace impeller Replace bearing
Overload trips	Pump locked up mechanically	Inspect pump hydraulics
	High on/of cycling frequency	Check application
Power consumption is too high	Wrong direction of rotation of impeller	See above
	Lime or other deposits mechanical friction	Clean pump mechanism repair pump
Motor overheats	High on/off cycling frequency	See above
	Wrong power supply (voltage or cycles)	Power supply must correspond with name plate rating
Pump does not pump	Insufficient cooling	Check air flow at motor fan
	liquid level too low Pump is empty Pump mechanism faulty Pipe blocked	Fill up liquid Fill up the pump replace pump mechanism Clean pipe
Insufficient flow and pressure	Air cannot escape from the discharge pipe	Inspect, check valve for leaks and refill pump
	Wrong direction of rotation of impeller	Change over two power supply leads
Incorrect flow or pressure	Pump mechanism silted up Worn pump mechanism	Clean pump mechanism Replace pump mechanism
	Wrong power supply (voltage or cycles)	Power supply must correspond with name plate rating
Running noise / Vibration	Foreign objects in pump end	Remove foreign objects
	Impeller damaged Bearing/Bushing broken Cavitation	Replace impeller Replace bearing/bushing Reduction of pump on pressure side

10 Spare part

10.1 Spare part list for the miniature centrifugal pumps series B401...B501

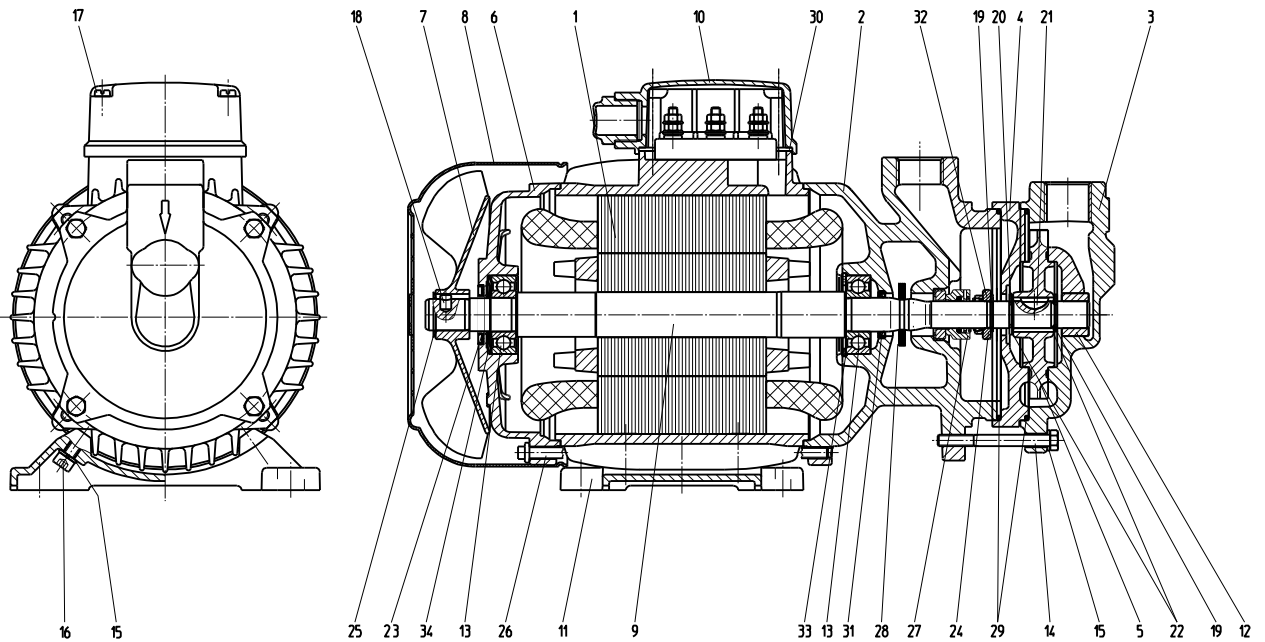

Item Description

1	Stator with terminal board	
2	Pump body	
3	Connecting cover (-F)	
4	Canal cover (-F)	
5	Impeller	
6	End shield	
7	Fan	
8	Fan cover	
9	Shaft with rotor	
10	Terminal box	
11	Stator base (-F)	
12	Bearing bush	
13	Ball bearing	DIN 625
14	Hexagon head cap screw	DIN 931
15	Spring washer (-F)	DIN 127
16	Hexagon socket head cap screw (-F)	DIN 912
17	Slotted cheese head screw	DIN 84
18	Parallel pin	DIN 7

Item Description

19	Locking ring	DIN 471
20	Locking disc	DIN 6799
21	Woodruff key	DIN 6888
22	Spacer ring	DIN 988
23	Shaft seal 0.92 kW	
24	Mech. Seal Stopp ring cover	
25	Retaining ring	
26	Stud bolt with bond	
27	Mechanical seal	
28	Splash ring	
29	O-ring	
30	Gasket	
31	Shaft seal	
32	Supporting ring	
33	Locking ring	DIN 472
34	Compensation disk	

Immersion Version

- (3) Inlet cover
- (4) Canal cover
- 35 Distance tube

10.2 Indications to the spare part order

Spare parts are available from the supplier. Standard commercially available parts are to be purchased in accordance with the model type. The ordering of spare parts should contain the following details:

1. Pumptype

e.g. B501

2. Pump No.

e.g. 06247400

The date of the construction year is a component of the pumps type number.

3. Voltage, Frequency and Power

Take item 1, 2 and 3 from the nameplate

4. Spare part with item No.

e.g. Impeller item No. 5

Tightening torques for screwed connections

Thread - Ø	M4		M5		
	Strength classes	4.8	4.8	A2	8.8
Tightening torque (Nm)	1 Nm	2 Nm	5 Nm	2 Nm	2 Nm
	Item 17	Item 26	Item 14	Item 16	

11 Repair

Brinkmann miniature centrifugal pumps series B401 ... B501

11.1 Exchange the rotary mechanical seal:

- 1) Disconnect the pump from the power supply.
Check up the marks on the pump unit.
- 2) Loosen hexagon head cap screws (14).
- 3) Loosen and remove Connecting cover (3) from canal cover (4). Remove the O-ring (29).
- 4) Remove locking disc 3 (20) and the spacer ring (22 on top). Push impeller (5) with help of two screwdrivers from the shaft (9). Set the screwdrivers between the impeller (5) and the canal cover (4).
- 5) Remove woodruff key (21) from the shaft (9) and remove the canal cover (4) with O-ring (29). Remove the spacer ring (22 at the bottom), locking rings 2 and 1 (19), the supporting ring (32), the mech. seal stopp ring cover (24) and the rotary mechanical seal part (27a-27d).
- 6) Remove the stationary mechanical seal part (27e-27f) from the pump body (2).
Clean pump parts and seat surfaces of all seals!

The rotary mechanical seal (27) should be replaced completely. If required, renew O-ring (29) and impeller (5).

- 7) Fit new rotary mechanical seal:

The running surfaces of the rotary mechanical seal must be free from dirt and grease. Wet the packing (27f) with water containing washing-up liquid and press the stationary rotary mechanical seal part (27e-27f) into the pump body (2). Push the rotary mechanical seal part (27a-27d) onto the pump shaft (9) and secure with the mech. seal stopp ring cover (24), with the supporting ring (32) and with the locking ring 1 (19).

- 8) The remaining assembly occurs in reverse order of item 3) to 5).

ATTENCION! Check the distance between the impeller and the canal cover it must be **0,3mm** for 50Hz version and **0,5mm** for 60Hz.

The impeller shall have a tight fit (by the number of the shim rings above and below).

Total of shim rings = 1.3mm!

Thus the upper shim rings may not be confused with the lower ones!

- 9) Screw the hexagon head cap screws (14).
Check up the tightening torque (5 Nm).
- 10) Reconnect pump to the electrical supply. **Fill up the pump!**

- 11) **Check direction of rotation!**

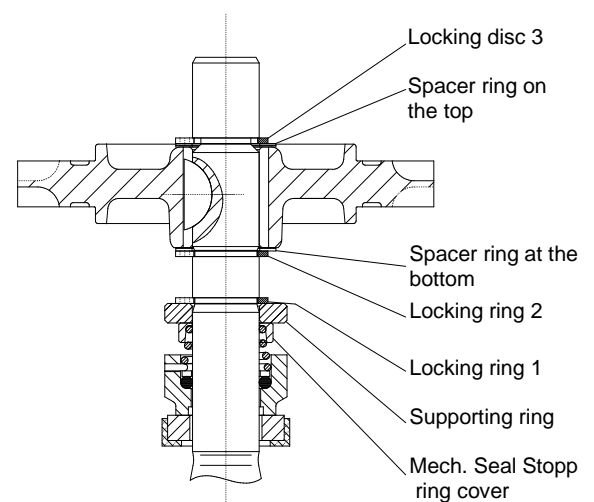
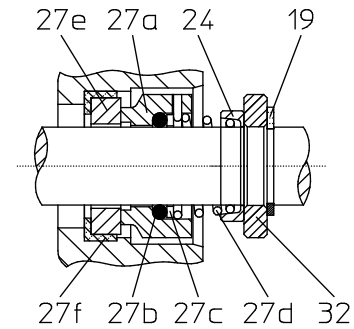

12 Disposal

When disposing of the pump or the packaging materials the local and national regulation for proper disposal must be complied with.

Prior to its disposal, the pump must be completely drained and decontaminated if necessary.

13 Declarations of conformity

13.1 UK declaration of conformity



UK declaration of conformity

Manufacturer

Brinkmann Pumpen, K. H. Brinkmann GmbH & Co. KG
Friedrichstraße 2
D-58791 Werdohl
Germany

This declaration of conformity is issued under the sole responsibility of Brinkmann Pumps and belongs to the following product.

Product name

Miniature Centrifugal Pumps

Type **B401 ... B501**

The named product described above complies with the following statutory requirements of United Kingdom:

UK SI 2008 No. 1597 The Supply of Machinery (Safety) Regulations 2008

UK SI 2016 No. 1091 The Electromagnetic Compatibility Regulations 2016

UK SI 2020 No. 1647 The Restriction of the Use of Certain Hazardous Substances in Electrical and Electronic Equipment Regulations 2020

The following exceptions in accordance with table 1, "Table of exempted applications" are claimed: No.12 (6a), No.15 (6b), No.18 (6C)

The following designated standards and technical specification have been applied:

EN 809:1998+A1:2009+AC:2010

EN ISO 12100:2010

EN 60204-1:2018

EN IEC 61000-3-2 :2019 +A1 :2021

EN 61000-3-3 :2013+A1 :2019 +A2 :2021 +A2 :2021/AC :2022

EN IEC 61000-6-2 :2019

EN IEC 61000-6-3 :2021

EN IEC 63000 :2018

Additionally the following standard has been applied:

EN 60034-1 :2010/AC :2010

The instructions contained in the operating manual for installation and start up the pump have to be followed.

**Brinkmann Pumpen, K. H. Brinkmann GmbH & Co.
KG**

Werdohl, 05.06.2024

.....
Dr.-Ing. Dirk Wenderott
Chief Product Officer (CPO)
Head of Engineering

Dr. H. Abou Dayé
K. H. Brinkmann GmbH & Co. KG
Friedrichstraße 2, D-58791 Werdohl
Representative of documentation

13.2 EC declaration of conformity

DEUTSCH / ENGLISH / FRANÇAIS / ESPAÑOL



EG-Konformitätserklärung

EC declaration of conformity / Déclaration de conformité CE / Declaración de conformidad CE

Hersteller / Manufacturer / Constructeur / Fabricante

Brinkmann Pumpen, K. H. Brinkmann GmbH & Co. KG
Friedrichstraße 2, D-58791 Werdohl

Produktbezeichnung / Product name / Désignation du produit / Designación del producto

Kleinkreiselpumpen / Miniature Centrifugal Pumps / Petites pompes centrifuges / Bombas centrifugas
Typ / Type / Tipo B401 ... B501

Das bezeichnete Produkt stimmt mit den folgenden Richtlinien des Rates zur Angleichung der Rechtsvorschriften der EG-Mitgliedsstaaten überein:

The named product conforms to the following Council Directives on approximation of laws of the EEC Member States:
Le produit sus-mentionné est conforme aux Directives du Conseil concernant le rapprochement des législations des Etats membres CEE:

El producto designado cumple con las Directivas del Consejo relativas a la aproximación de las legislaciones de los Estados Miembros de la CEE:

2006/42/EG	Richtlinie für Maschinen
2006/42/EC	Council Directive for machinery
2006/42/CE	Directive du Conseil pour les machines
2006/42/CE	Directivas del Consejo para máquinas
2014/30/EU	Richtlinie für elektromagnetische Verträglichkeit
2014/30/EU	Council Directive for Electromagnetic compatibility
2014/30/UE	Directive du Conseil pour Compatibilité électromagnétique
2014/30/UE	Directivas del Consejo para Compatibilidad electromagnética

2011/65/EU und 2015/863/EU	RoHS Richtlinien
2011/65/EU and 2015/863/EU	RoHS Directives
2011/65/UE et 2015/863/UE	Directives RoHS
2011/65/UE y 2015/863/UE	RoHS Directivas

Folgende Ausnahmen gem. Anhang III RoHS (2011/65/EU) werden in Anspruch genommen: 6a, 6b, 6c.

The following exceptions in accordance with appendix III RoHS (2011/65/ EU) are claimed: 6a, 6b, 6c.

Les exceptions suivantes selon l'annexe III RoHS (2011 / 65 / UE) sont revendiquées : 6a, 6b, 6c.

Las siguientes excepciones conforme al apéndice III RoHS (2011/65 / UE) son requeridas: 6a, 6b, 6c.

Hinsichtlich der elektrischen Gefahren wurden gemäß Anhang I Nr. 1.5.1 der Maschinenrichtlinie 2006/42/EG die Schutzziele der Niederspannungsrichtlinie 2014/35/EU eingehalten.

With respect to potential electrical hazards as stated in appendix I No. 1.5.1 of the machine guide lines 2006/42/EC all safety protection goals are met according to the low voltage guide lines 2014/35/EU.

Conformément à l'annexe I N° 1.5.1 de la Directive "Machines" (2006/42/CE) les objectifs de sécurité relatifs au matériel électrique de la Directive "Basse Tension" 2014/35/UE ont été respectés.

Con respecto al potencial peligro eléctrico como se indica en el apéndice I No. 1.5.1 del manual de la máquina 2006/42/CE, todos los medios de protección de seguridad se encuentran según la guía de bajo voltaje 2014/35/UE.

Die Übereinstimmung mit den Vorschriften dieser Richtlinien wird nachgewiesen durch die vollständige Einhaltung folgender Normen:

Conformity with the requirements of this Directives is testified by complete adherence to the following standards:

La conformité aux prescriptions de ces Directives est démontrée par la conformité intégrale avec les normes suivantes:

La conformidad con las prescripciones de estas directivas queda justificada por haber cumplido totalmente las siguientes normas:

Harmonisierte Europ. Normen / Harmonised Europ. Standards / Normes europ. harmonisées / Normas europ. Armonizadas

EN 809 :1998+A1 :2009+AC :2010 EN ISO 12100 :2010 EN 60204-1 :2018 EN IEC 61000-3-2 :2019 +A1 :2021
EN 61000-3-3 :2013+A1 :2019 +A2 :2021 +A2 :2021/ZAC :2022 EN IEC 61000-6-2 :2019 EN IEC 61000-6-3 :2021
EN IEC 63000 :2018

Nationale Normen / National Standards / Normes nationales / Normas nacionales : **EN 60034-1 :2010/AC :2010**

Die Hinweise in der Betriebsanleitung für den Einbau und die Inbetriebnahme der Pumpe sind zu beachten.

The instructions contained in the operating manual for installation and start up the pump have to be followed.

Les indications d'installation / montage et de mise en service de la pompe prévues dans l'instruction d'emploi doivent être suivies.

Tenga en cuenta las instrucciones en el manual para la instalación y puesta en marcha de la bomba.

Brinkmann Pumpen, K. H. Brinkmann GmbH & Co. KG

Werdohl, 05.06.2024

.....
Dr.-Ing. Dirk Wenderott
Chief Product Officer (CPO)
Head of Engineering

Dr. H. Abou Dayé

K. H. Brinkmann GmbH & Co. KG
Friedrichstraße 2, D-58791 Werdohl

Dokumentationsbevollmächtigter / Representative of
documentation/ Mandataire de documentation /
Mandatario de documentación