

BE6100 Operating Instructions

(Translation of original)

BRINKMANN-Screw Pump

BFS / TFS / FFS / BFS-H / TFS-H / BFG / FFG

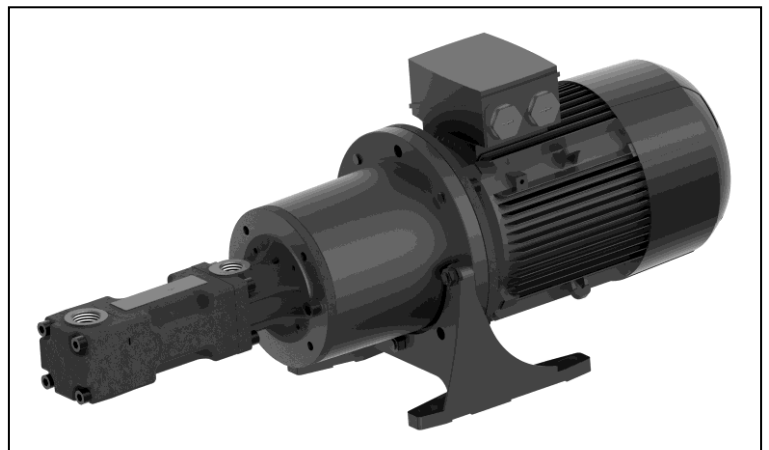
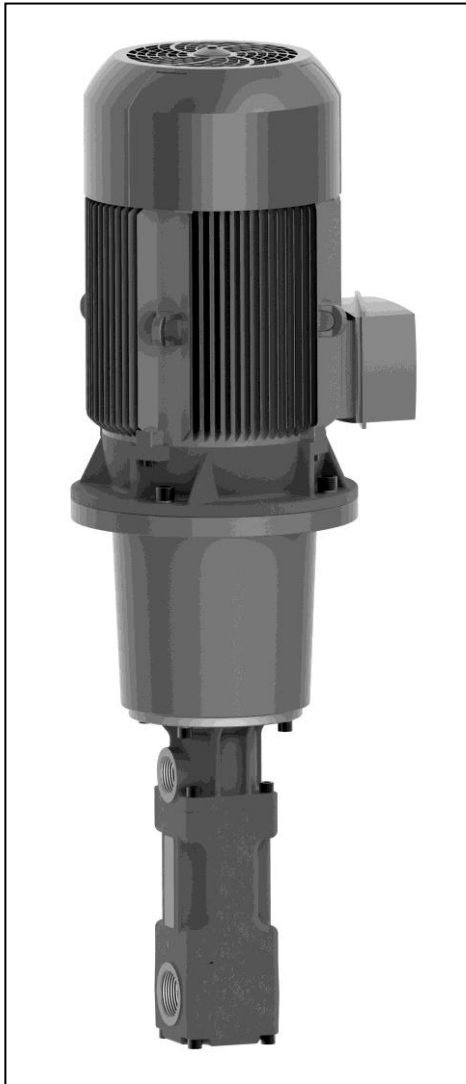

Brinkmann Pumpen
K. H. Brinkmann GmbH & Co. KG
Friedrichstraße 2 D-58791 Werdohl
Tel.: +49-2392 / 5006-0
Fax.: +49-2392 / 5006-180

Subject to change without prior notice.

www.brinkmannpumps.de
sales@brinkmannpumps.de

Order - No. : BE6100 ENGLISH

BRINKMANN-Screw Pump Type BFS / TFS / FFS

Contents

1	Indication to the manual	2	9	Trouble shooter's guide.....	10
2	Description of product and working principle	2	10	Spare part	11
3	Safety instructions	4	11	Repair Instructions	12
4	Transport, and Temporary storage	5	12	Disposal	13
5	Installation / Connection	6	13	Declarations of conformity.....	14
6	Start up / Shut down.....	8			
7	Operation.....	9			
8	Servicing and Maintenance	9			

1 Indication to the manual

This operating manual gives basic instructions which are to be observed during installation, operation and maintenance of the pump. It is therefore imperative that this manual be read by the responsible personnel and operator prior to assembly and commissioning. It is always to be kept available at the installation site.

1.1 Identification of safety instructions in the operating manual

Safety instructions given in this manual non-compliance with which would affect **safety** are identified by the following symbol



Safety sign according with ISO 3864–B.3.1 or where **electrical safety** is involved, with



Safety sign according with ISO 3864–B.3.6

Where non-compliance with the safety instructions may cause a risk to the machine and it's function the word

ATTENTION

is inserted.

2 Description of product and working principle

2.1 Scope

Pumping of fluids at high backpressure. The discharge pressure needs to be at least 2 bar higher than the inlet pressure.

2.2 Application range

- Screw pumps are designed for pumping filtered, lubricating fluids (Please consult with the manufacturer for specific applications).
- Screw pumps are used in applications where high pressures and constant flow rates are required (e.g. general machine design, machine tool industry, etc.)

Operate pump within the design limitations and in accordance with section 2.6.

2.3 Working principle

- The intermeshing threads of three screw spindles generate liquid holding chambers.
- The center spindle is driven and all three screw spindles rotate.
- The medium moves continuously and without noticeable pulsation toward the pump discharge.

- Proper clockwise rotation must be ensured at all times. Incorrect counterclockwise rotation will result in dry running and pump damage. Catastrophic failure is possible!
- Screw pumps are self-priming, however, dry running must be avoided under any circumstances as it will almost instantly damage the pump and it might result in catastrophic failure.
- Screw pumps are positive displacement pumps and must therefore always be used in combination with a pressure limiting valve or pressure relief valve.

2.4 Type code structure (example)

High pressure screw pump: BFS 250 / 80 -G

Pump series designation	BFS, TFS or FFS	
Pump size	250	
Maximum pressure in bar	80	
Special features	-G	

(e.g. with mechanical seal)

2.5 Pump Models

Immersion style

BFS, TFS (-H) pressure outlet above tank plate

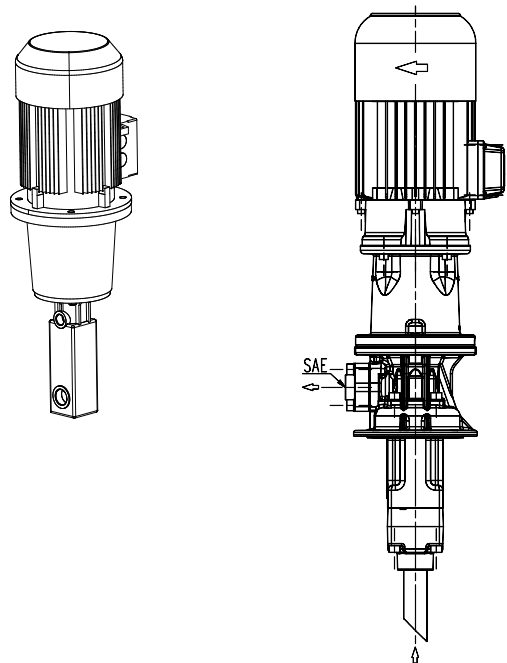

FFS foot mounted inline style

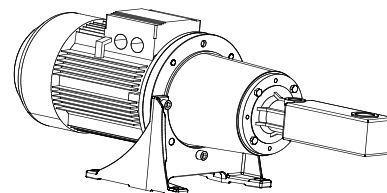

2.6 Limit of Application

Type	BFS, TFS, FFS
Mediums	Oils, cooling / cutting oils coolants
Max. delivery pressure	80 bar (BFG, FFG with cast iron spindle housing) 150 bar (200 bar for BFS/FFS1, BFS/FFS2 and TFS/BFS/FFS3 upon request) 120 bar (-H)
Minimum discharge pressure	Ensure that the discharge pressure is at least 2 bar higher than the inlet pressure
Minimum inlet pressure In order to prevent damage from cavitation	0.8 bar absolute, with increased fluid temperature also more, (Pumps with a flow rate of greater than 800 l/min have to be operated in conjunction with a feed pump > 1 bar).
Kinetic viscosity of the medium	1...45 mm ² /s (cSt) higher viscosities upon request
Max. temperature of medium	60 °C over 60 °C on request
Max. air content	3 – 5 vol. %
Max. inlet pressure with mechanical seal	< 7 bar
Execution -G4	20 bar
Concentration of coolant lubricants and water soluble coolants	The fluid must have a minimum lubricity in accordance with industry standards. A typical emulsion with oil content should have at least an overall concentration of 4%, (which means a pure oil content of 2%). A laboratory analysis is available at the factory.
Minimum flow rate	The minimum flow rate must be large enough to protect the pump from overheating. If necessary, consult with the manufacturer on exact flow rate.
Minimum rpm	25 Hz (1500rpm), lower rpm are available upon request. The minimum rpm depends on the pressure and medium.
Dry running	The pump MUST never be run dry without fluid. When testing for the direction of rotation, bump the pump for not longer than 1 second.
Cycle times per hour	Motors less 3 kW max. 200 from 3 kW to 4.0 kW max. 40 from 5.0 kW to 9.0 kW max. 20 from 10 kW to 22 kW max. 15 Increased cycle times are available upon request.
Maximum fluid velocity at pump suction	2 m/s
Installation positions	(Pump must not be installed with motor facing down)
Piping / Fittings	Pay attention to max. pressure ratings
Ambient temperature	40 °C
Set-up altitude	1000 m

ATTENTION

The pumps are to be operated within their design limits. Applications outside of these limits are not approved. The manufacturer is not responsible for any damages resulting from use of the pumps in such applications.

2.7 Important instructions for screw pumps



- Never allow screw pumps to run dry!
- Incorrect rotation will lead to pump damage!
- Sufficient fluid supply must always be ensured!
- Large particles in the coolant fluid may damage the screw pump!
- The limits for size and concentration of foreign particles depends on their hardness!

Materials	Particle size	Particle concentration:
Steel / Forgeable aluminium alloys (without Si content) / GG25 BFG, FFG, BFS, FFS	< 60 µm	< 177 mg/l
Grey cast iron with hard additives (e.g. GGv) BFS, FFS	< 50 µm	< 63 mg/l
Ceramic/ corundum / hard metal / glass / CBN Aluminium alloy with Si parts BFS, FFS	< 20 µm	< 19 mg/l

The particle concentration refers to standardized test.

For additional information please refer to the filtration diagram in the screw pump catalogue.

ATTENTION

If high pressure screw pumps are to be used outside of the recommended ranges, a suitable filter system (e.g. filter bags) must be installed upstream from the pump or pumps with special features must be used (e.g., with coated spindles).

If pump failure is caused by excessive wear due to foreign particles, the warranty is void!

In applications where hard or abrasive particles are present, the use of coated spindles is highly recommended.

2.8 Technical data

Detailed technical data can be found in the screw spindle pump catalogue.

3 Safety instructions

When operating the pump, the safety instructions contained in this manual, the relevant national accident prevention regulations and any other service and safety instructions issued by the plant operator are to be observed.

3.1 Hazards in the event of non-compliance with the safety instructions

Non-compliance with the safety instructions may produce a risk to the personnel as well as to the environment and the machine and results in a loss of any right to claim damages. **For example**, non-compliance may involve the following hazards:

- Failure of important functions of the machines/plant
- Failure of specified procedures of maintenance and repair
- Exposure of people to electrical, mechanical and chemical hazards
- Endangering the environment due to hazardous substances being released

3.2 Unauthorized modes of operation



- Pump may not be used in potentially explosive environments!
- Pump and discharge piping are not designed to hold any weight and may not be used as a step ladder.

3.3 Remaining Risk



Risk of Injury!

Risk of squeezing or crushing body parts when installing or removing the pump exists. Proper and secured lifting tools must be used.

Risk of burns!

The pump must have cooled down sufficiently prior to commencing any repair, maintenance or installation.

3.4 Qualification and training of operating personnel

The personnel responsible for operation, maintenance, inspection and assembly must be adequately qualified. Scope of responsibility and supervision of the personnel must be exactly defined by the plant operator. If the staff does not have the necessary knowledge, they must be trained and instructed, which may be performed by the machine manufacturer or supplier on behalf of the plant operator. Moreover, the plant operator is to make sure that the contents of the operating manual are fully understood by the personnel.

3.5 Safety instructions relevant for operation

- If hot or cold machine components involve hazards, they must be guarded against accidental contact.
- Guards for moving parts (e.g. coupling) must not be removed from the machine while in operation.
- Never subsequently alter any safety devices (e.g. pressure relief valves)!
- It is necessary to ensure that all safety devices always work properly!
- Any leakage of hazardous (e.g. explosive, toxic, hot) fluids (e.g. from the shaft seal) must be drained away so as to prevent any risk to persons or the environment. Statutory regulations are to be complied with.
- Hazards resulting from electricity are to be prevented (see for example, the VDE Specifications and the bye-laws of the local power supply utilities).
- The pumps' stability against falling over is not ensured unless it is properly mounted onto the tank or to the floor.
- The female threads on the motor **MUST NOT** be used to lift the entire pump and motor assembly.

3.6 Safety instructions relevant for maintenance, inspection and assembly work

Any work on the machine shall only be performed when it is at a standstill, it being imperative that the procedure for shutting down the machine described in this manual be followed.

Pumps and pump units which convey hazardous media must be decontaminated.

On completion of work all safety and protective facilities must be re-installed and made operative again.

Prior to restarting the machine, the instructions listed under "Start up" are to be observed.

3.7 Signs on the pump

It is imperative that signs affixed to the machine, e.g.

- arrow indicating the direction of rotation
- symbols indicating fluid connections

be observed and kept legible.

3.8 Unauthorized alterations and production of spare parts

Any modification may be made to the machine only after consultation with the manufacturer. Using spare parts and accessories authorized by the manufacturer is in the interest of safety. Use of other parts may exempt the manufacturer from any liability.

4 Transportation and Temporary Storage

Protect the pump against damage when transporting.

The pumps may only be transported in a horizontal position and hooks or straps must be attached on the motor and pump end.

Store pump in dry and protected areas and protect it against penetration of foreign bodies.

Always store pump above the freezing point!

Pumps are factory preserved.

If storage exceeds 6 months, the preservation should be checked and reapplied if applicable.

Pumps that have been immersed or have been running must be cleaned and preserved prior to storage. This applies especially to water based fluids!

4.1 Pump Preservation

4.1.1 Draining pump

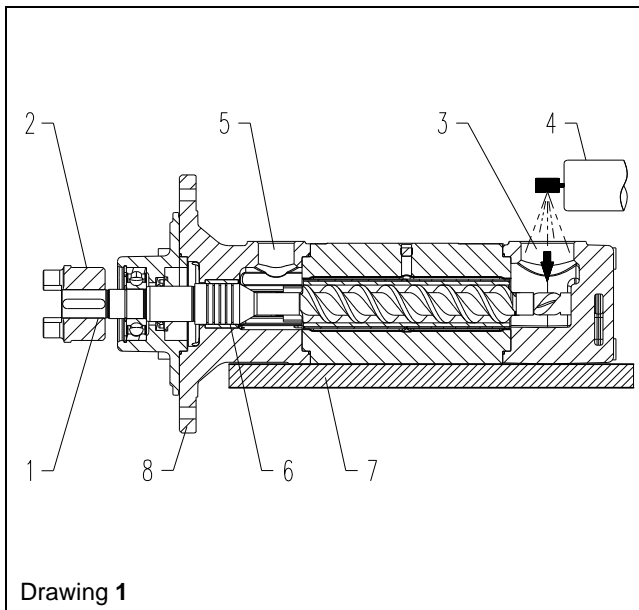

1. Separate pump and motor.
2. Clean the pump body thoroughly
3. Outlet (5) and Inlet port should be open.
4. Stand pump up with the coupling (2) facing up tilting it in direction of the inlet port (3).
5. Turn motor shaft (1) **counterclockwise**. Keep pump tilted until it is completely drained.

Pumps with mechanical seal –G or axial thrust –A:

6. Place pump on a work bench (7) horizontally with the threaded port facing up. The flange (8) may not touch the surface. See picture 1.
7. Plug outlet port (5) with a **sealing** plastic cap.
8. Turn the motor shaft as quickly as possible **counterclockwise**. This will allow for the remaining fluid to drain from the adjacent cavities (6).
9. Repeat steps 1-8 until no more fluid drains.

4.1.2 Pump preservation

Interior Preservation

1. Outlet (5) and inlet port (3) should be open.
2. Place pump on a work bench (7) horizontally with the threaded port facing up. The flange (8) may not touch the surface.
3. Pour preservation agent (spray oil) into the inlet port (3) and turn motor (1) shaft **clockwise** until it becomes visible at the outlet port and the fluid level of the oil is above the lowest point of the labyrinth seal area.

Pumps with mechanical seal –G or axial thrust –A:

4. Plug outlet port (5) with a sealing plastic cap.
5. Turn motor shaft (1) **clockwise** as quickly as possible by hand in order for the preservation agent to enter into the adjacent cavities (6).

Exterior Preservation

6. Preserve all unpainted metal components

Drain excess preserving agent and plug outlet and inlet ports with plastic caps.

Collect draining coolant and oil and dispose in accordance with applicable local laws and regulations!

5 Installation / Connection

5.1 Mechanical installation

Installation

The pumps can be mounted either horizontally (foot mounted inline version) or vertically (immersion style).

For safety reasons installations with "motor facing down" are not allowed".

Pumps must be mounted securely. Piping, tank and pumps must be mounted without any tension. The actual mounting of the pumps depends on size, style and motor used and might be influenced by actual limitations or restrictions on site. In any case, the pumps must always be mounted securely.

Piping

- Follow the recommended piping installation guide lines as well as the required tightening torques (see tables 1 and 2).
- Work carried out on high pressure screw fittings, pipes and hoses should only be performed by authorized specialists and must consider the applicable standards and local legislation.
- Only use components which are rated for high pressure (i.e. no brass)!
- Do not use fluid sealant or adhesives near the pump or the pressure relief valve (risk of bonding).
- Connect and disconnect the pressure line only when pump and relief valve are de-energized.
- Do not prop up the pressure line via the joining socket.
- Do not climb onto the pressure line.
- Connect the suction line, pressure line and positive pressure outflow line as shown in drawing 2, see chapter 7.1.

ATTENTION

Pay attention of the max. tightening torque for piping connections!

Pipe connection	Cast iron
G ½	70 Nm
G ¾	80 Nm
G 1	90 Nm
G 1 ½	150 Nm
G 2	170 Nm
G 2 ½	200 Nm
G 3	230 Nm
G 3 ½	260 Nm

Table 1

Tightening torques for screws connections of SAE flanges!

SAE flanges	G 1	G 2 ½	G 3
Thread - Ø	M10	M12	M16
Strength classes	12.9	8.8	8.8
Tightening torque (Nm)	55 Nm	70 Nm	70 Nm

Table 2

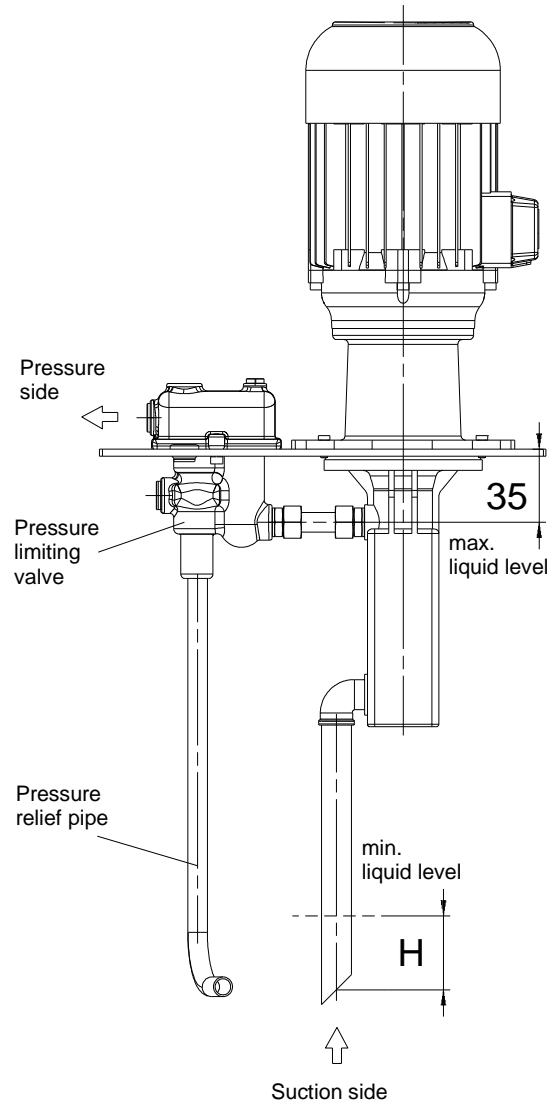

Drawing 2

-H Execution

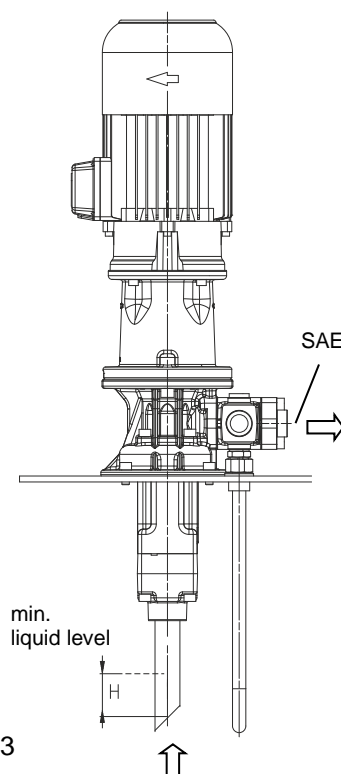

Drawing 3

- In the case of a G4 execution, the leakage connection must be piped without back pressure (see drawing 4) and routed back into the tank in a non-pressurised state. The connection **MUST** never be closed or valved off.

Pressure relief valves (DBV's)

- Always protect screw pumps against pressure overload, **-do not use screw pumps without pressure relief valves!**
- When operating pressure relief valves, it is **forbidden** to operate the pump **above the stated nominal pressure**.
- Check the function of the pressure relief valve after longer downtimes.
replace damaged parts if necessary.
- Every pressure limiting valve provided by the manufacturer is adjusted to a specific pressure and is designed to meet the requirements of the application. Nevertheless, in isolated instances, interaction (i.e. vibrations) between the pressure relief valve and other system components can occur.
- When using third party valves, adjustable valves or multiple valves in parallel the following conditions must be ensured:
 1. To protect the motor and pump from overloading the valves must be set to a specific maximum opening pressure (valves must be sized to handle 100% of the pump's flow rate).
 2. When using multiple valves in parallel, the individual opening pressures of the valves must vary from each other to avoid multiple valves opening simultaneously. Otherwise resonances and vibrations can occur. Our technical department is glad to advise you with regards to your particular case.

ATTENTION

Defective pressure relief valves may lead to pump damage.

Excess pressure can also damage other system components or cause human injuries.

Do not direct the bypass flow from the pressure relief valve directly into the pump supply line (Danger of overheating).

Pressure Gauge

- Briefly open shutoff valve at the pressure gauge to check for proper supply pressure, then close again. The shutoff valve protects the pressure gauge from pressure surges, which may damage the pressure gauge.

Piping

- No pipes or fittings mounted to the pump system should not put any physical stress on the pump components.
- Avoid any unnecessary changes in pipe cross-sections or in pipe direction (this can cause noise).
- The nominal pipe diameters may not be smaller than the nominal diameter of the pump suction and discharge.
- Clean all pipes, fittings and fixtures: remove burr and welding beads; clean tanks thoroughly.
- Flange gaskets must not protrude inside into the pipe.
- Make sure that NO metal chips or fines can fall into the tank after initial pump installation (e.g. drilling holes in tank lid for name plate mounting, etc).

Air relief valve

- The installation of an air relief valve at the highest point of the discharge pipe is recommended.
- **Attention!** If the end of the discharge piping is located below the clean tank in a closed loop arrangement the clean tank may drain due to the elevation difference. This can be avoided by installing check valves or air relief valves.

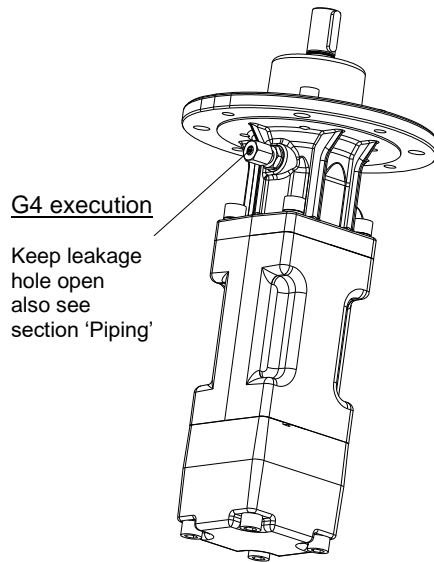

Drawing 4

5.2 Electric wiring



All service work must be carried out by qualified service personnel. Pump must be disconnected from the power source and all rotating parts must stand still. Reassure that pump is disconnected from power source and cannot be switched on.

Verify that there is no voltage at the terminal board!

The motor is surface-cooled and compliant with DIN IEC 34 and EN 60034 (protection degree IP 55).

According to the European Standard EN 809 a motor overload must be installed and properly set to the full load amps stated on the pump name plate.

It is the responsibility of the machine operator to decide whether or not an additional emergency switch must be installed.



Danger!

Risk of electric shock

Our asynchronous motors can optionally be fitted with temperature sensors in the form of triplet PTC thermistors, which are used for thermal monitoring of the motor windings. Please note that the temperature sensors meet the insulation requirements of basic insulation. The improper connection of the triplet PTC thermistors to evaluation units that do not have a protective function against overvoltage in the event of a fault can lead to voltages dangerous to the touch and electric shock.

Please check whether the evaluation units you intend to use are permissible for the electrical connection of the temperature sensors.

5.2.1 Circuit



Tension voltage and frequency must correspond with the shown specification on the nameplate.

The pump must be wired so that a solid longterm electrical connection is ensured. Establish a solid ground connection.

The electrical wiring must be performed according to the wiring diagram shown inside the terminal box cover. (Please see above sample wiring diagrams)

Wiring diagram e.g.

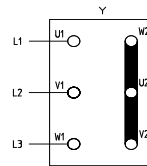

Star connection
(Standard up to 5.5 kW)
3 x 400 V, 50 Hz
resp. 380-415 V, 50 Hz

resp.

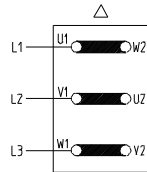

Delta connection
(Standard as of 6.0 kW)
3 x 400 V, 50 Hz
resp. 380-415 V, 50 Hz

Standard motors are operated in the delta connection but can also be started up with a star-delta start up unit in order to reduce the in rush current. In this case, make sure you start up the pump with minimal back pressure, as otherwise the pump may run backwards when switching over from star to delta!

There may be no foreign objects such as dirt, particles or humidity inside the terminal board.

Mount terminal board cover to motor tight against dust and humidity and close up all unused wiring ports.

ATTENTION

When Variable Frequency Drives are used interfering signals might occur.

Non-sinus shaped supply voltage from a variable frequency drive might result in elevated motor temperatures.

6 Start up / Shut down

6.1 Start up / Turn motor on

- Open all valves in discharge line completely and de-energize pressure relief valve (start up pump without any backpressure).
- Open the shut off valve on the suction-side of the pump.
- Ensure sufficient liquid level in tank.
- In case of a horizontal installation, the pump must be filled prior to initial start-up.
- Attention! The temperature difference between pump and the pumped medium should be minimal prior to start-up to avoid thermal shock!
- After connecting the electrical wires, close the terminal box, switch on the motor and check for the direction of rotation in the following manner:

ATTENTION

- The motor's direction of rotation must correspond with the pump's directional arrow (direction of rotation is clockwise with a view onto the fan cover).
- Check the pumps operation with 2 people, i.e. 1 person should start the motor as recommended (running for 1 sec. max.) and the other person should monitor the direction of the motor.



● Risk of Injury!

It is not permitted to run the pump without any medium (dry run). This can damage the pump. Do not put defective pumps back into operation!

- Check suction and pressure pipes for any leaks; avoid admission of air into the pump system.
- Monitor pressure and temperature monitoring devices frequently.

6.1.1 Initial start-up of pumps with mechanical seal –G

- During the initial start –up or after longer storage spray the interior of the pump with spray oil and turn by hand if applicable.
- Start pump with minimized pressure and bleed air completely (short run time!)
- Maximum operating pressure must be reached immediately afterwards resulting in ventilation and lubrication of the sealing area.

Foot-mounted inline Pumps with FFS-Standard

- Operating pressure must be larger than incoming supply pressure at the pump suction,
Attention! Danger of overheating the seal
- No negative pressure or vacuum conditions on the suction side,
Attention! Dry running of the mechanical seal.

6.2 Turn off

- Turn off motor.
- For longer downtime periods, dismantle and preserve pump

6.3 Shut down

- All service work must be carried out by qualified service personnel. Pump must be disconnected from the power source and all rotating parts must stand still. Reassure that pump is disconnected from power source and cannot be switched on.
- Verify that there is no voltage at the terminal board!
- Turn off motor
- Open terminal box and disconnect the power leads.
- Close all valves!
- Empty out the pump.
- Remove all materials which could potentially cause harm to humans or the environment!
- Coolants must not pollute the environment!
- Depressurize the system!
- When handling toxic materials, wear safety glasses, protective clothing and protective gloves!

7 Operation

7.1 Liquid level

- Check for proper liquid level.

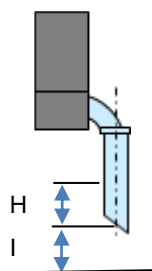

- The minimum liquid level (H, see also drawing 2 and 3) should be ≥ 70 mm for BFS, BFG, BFS-H, TFS-H and TFS3, ≥ 100 mm for TFS4 and TFS5 and ≥ 150 mm for TFS6.

- Maximum liquid level is 35 mm below the pump's mounting plate.
- The distance I between the suction pipe and the bottom of the tank is ≥ 100 mm for BFS, BFG, BFS-H, TFS-H, TFS3, TFS4 and TFS5 and ≥ 150 mm for TFS6. These distances must be adhered to.
- Using the patented Brinkmann suction protector prevents large particles and foreign objects from entering the screw pump. The protector extends the life expectancy of the pumps significantly. In addition, the large surface area of the suction protector prevents the pump from drawing air which can be caused by a funneling effect at the suction pipe if no suction protector is used.
- The pump may only be installed and operated in a suitable container!
- Operation is only permitted with a suction pipe, suction line or suction protector.



Risk of Injury!

Never operate screw pumps dry.

Sufficient fluid level must always be ensured.

Avoid hydraulic shocks!

7.2 Signs of abnormal operating behaviour

- Discolouration, noises and vibrations in the vicinity of the adaptor cap point to problems with the main drive spindle bearing. In order to avoid hazards, the pump should be put out of service immediately!
- When the pump noise increases, this indicates to a medium with insufficient lubricity, or wear and tear.
- If the noise increases to a level which is no longer permitted or in the case of strong vibrations, the pump should be exchanged immediately.

7.3 Operation with a frequency inverter

- When operating with a frequency inverter, the user must ensure that it has a safety reserve of 10% in terms of the nominal voltage of the motor. In addition, the size of the motor should provide a safety margin of 10 % with respect to the max. pump output.
- When operating with a frequency inverter it is necessary to follow the permitted minimum speeds and maximum speeds. These depend on the pressure, medium and pump model. If necessary, consult with the factory.
- Please follow the separate operating instructions for the frequency inverter (jointly supplied).

7.4 Operation with a pressure relief valve

- When operating with a pressure relief valve the user should bear in mind that the self-setting operating pressure depends on the flow rate, especially in the case of spring-controlled valves. As such, the operating pressure should not be insignificantly above the opening pressure of the valve. The motor power is to be adequately rated according to the maximum prevailing pressure.

-
- In addition, please follow the separate operating instructions for the pressure relief valve (jointly supplied).

7.5 Operation with mechanical seal -G and FFS pump series (inline)

- The mechanical seal gets damaged and destroyed by pressure spikes, which therefore must be avoided on the system side. Pumps equipped with the -G4 feature are not affected by this.
- Due to the design principles of mechanical seals, leakage flow always occurs. The leakage can (if necessary) be captured and redirected from the threaded opening in the bearing cover.
- Please ensure that pumps equipped with mechanical seal -G or of the FFS series pumps (inline version) have always a flooded suction and are operated with a positive supply pressure. Operating these pumps under negative pressures can cause mechanical seal damage / failure due to lack of

lubrication on the seal faces. Pumps equipped with the -G4 feature are not affected by this.







If the pump becomes blocked, do not operate the pump any longer (see point 6.3) and send it to the manufacturer for repair.

8 Servicing and Maintenance

ATTENTION

- The surface of the motor must be kept free of dirt.
- BRINKMANN-Screw pumps are maintenance free.
- In case of damage, pump must be sent back to the manufacturer.
- Unauthorized repair work or opening of the pump will void all warranties!

9 Trouble shooter's guide

Fault	Possible causes	Remedy
Pump does not pump	Incorrect direction of rotation of pump 	Reverse direction of rotation of motor.
	Pump is operating without fluid 	Add pumping fluid; raise fluid level in tank.
	Shut-off valves are closed	Open valves
	All fluid is pumped through a bypass line	Check bypass lines and relief valve settings.
	Broken pressure relief valve	Replace pressure relief valve, check pressure.
	Pump is blocked 	Exchange pump immediately. Do not turn the motor on again! Send the pump to the manufacturer to be repaired.
Pump does not de-aerate	No possibility for de-aeration provided	Install air relief valve in the discharge line or start up pump with de-energized relief valve.
Pump does not operate at full capacity	Suction line is leaking	Tighten the flange screw fittings and replace seals.
	A bypass is in open	Check the piping and correct the bypass / leakage.
	Suction pipe too close to tank bottom	Use Brinkmann suction protector; shorten suction pipe; cut suction pipe at 45 degree angle
	Upstream or downstream filters clogged	Clean or replace filter.
	The pump is worn out	If necessary, improve the filtration. If you are familiar with the equipment, exchange the spindle set. Otherwise, send the pump to the manufacturer.
Pump is operating loudly	Suction line is leaking; pump is drawing air	Tighten fittings and pipe connections; replace seals or gaskets in suction line if necessary.
	The suction height is greater than 1.2 m and/or the total input pressure is < 0.8 bar.	Raise fluid level in tank or lower pump.
	Pump is cavitating because the temperature of the pumped liquid is too high.	Increase the supply or inlet pressure. Lower the temperature of the pumped liquid. Consult with the manufacturer.
	System pressure is too low	Check the size of the primary pressure pump.
	Incorrect opening and closing sequence of the suction side valves	Correct the valve opening sequence so that the pump only starts when the valve is open. Only close the valve when the pump no longer rotates. In general, avoid suction side valves.
	Air pockets or air entrainment in the pumped medium or pump sucks air.	Ensure that air is discharged better in the container. Check the proper seal/connection of the suction pipe.
	Resistance in suction line too high	Increase suction pipe diameter; check for restrictions (elbows etc.)
	Suction pipe too close to tank bottom	Use Brinkmann suction protector; shorten suction pipe; cut suction pipe at 45 degree angle
	Fluid viscosity too high	Feed screw pump by secondary feed pump after consulting with the manufacturer
	The pump is worn out	If necessary, improve the filtration. If you are familiar with the equipment, exchange the spindle set. Otherwise, send the pump to the manufacturer.
	Upstream or downstream filters clogged	Clean or replace filter
	Auxiliary equipment causes noises	Noises can also arise as a result of defective pressure relief valves, an unfavourable path taken by the pipework or a lack of ventilation. Establish the source of the noise and eliminate the root cause.
	Pressure relief valve vibrates / pulses 	Readjust pressure relief valve. (Relief pressure setting should be 10% above operating pressure as long as approved), make sure that valve is fully purged from any air, exchange valve for another valve of different operating principle, or alter / modify system components to change system harmonics. Consult with manufacturer if necessary.
	Inline pump is leaking	The ring seal is worn out or soiled Otherwise, send the pump to the manufacturer in order for it to be repaired. Check the equipment for hydraulic shock and suction side negative pressure when switching. If necessary, improve the filtration.

 : Will result in immediate pump damage or hazards

10 Spare part

10.1 Pump design BFS, TFS

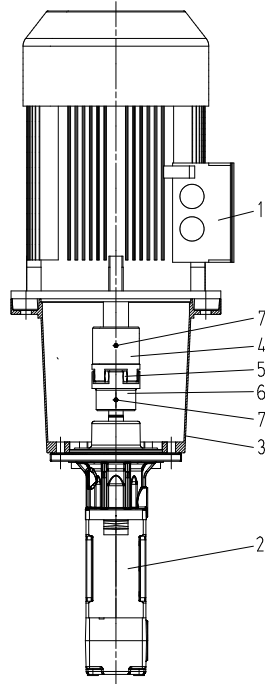

FFS

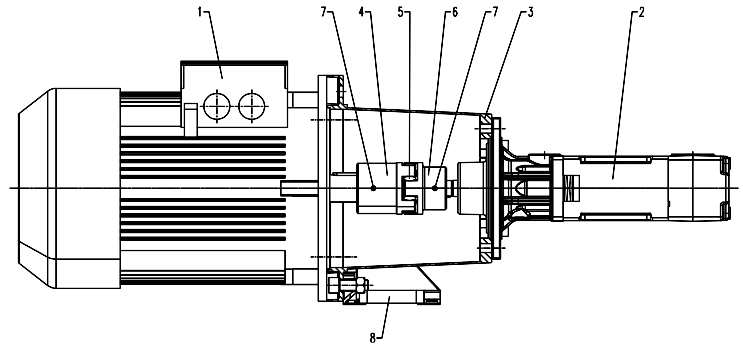

Item Description

- | | |
|---|--------------------|
| 1 | Motor |
| 2 | Screw pump |
| 3 | Bell housing |
| 4 | Motor coupling hub |
| 5 | Coupling spider |
| 6 | Pump coupling hub |
| 7 | Set screw |
| 8 | Pump foot |

10.2 Indications to the spare part order

Spare parts are available from the supplier. Standard commercially available parts are to be purchased in accordance with the model type. The ordering of spare parts should contain the following details:

1. Pump Type

e.g. TFS364/60

2. Pump No.

e.g. 06246100

The date of the construction year is a component of the pumps type number.

3. Voltage, Frequency and Power

Take item 1, 2 and 3 from the nameplate.

4. Spare part with item No.

e.g. Motor 1

11 Repair Instructions

11.1 Fitting the coupling

- Coat pump and motor shaft ends with a thin coat of Molykote (e.g. Molybdenumdisulfphite) and insert the woodruff key.
- Slide the pump coupling hub (6) onto the pump shaft by using a rubber mallet. Move pump coupling hub down as showing in following table and drawing.

If the hub installation is too difficult, warming up the coupling hubs will simplify the hub installation.

- Secure the pump coupling hub (6) using the set screw (7)
- Clean motor shaft with solvent to remove any anti-rust coatings. Then coat the motor shaft with a thin layer of Molykote (e.g. Molybdenumdisulfphite) and insert the woodruff key.
- Slide the motor coupling hub (4) onto the motor shaft to dimension as shown in following table (Page 11) and drawing
- Secure the motor coupling hub (4) using the set screw (7).

Dimensions for BFS1/BFS2 (2 pole motors):

In each case the distance is measured by the inner surface of the coupling hub to the shaft end

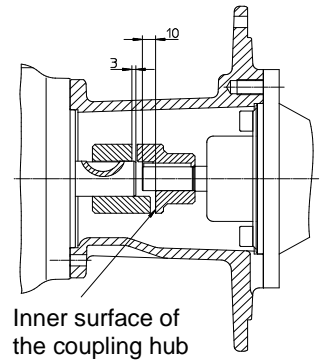

Inner surface of the coupling hub

Dimensions for TFS1/FFS1... TFS6/FFS6 (2 pole motors):

Frame size	Power 50 Hz / 60 Hz kW	TFS1, TFS2			TFS3			TFS4			TFS5 / TFS6		
		A mm	B mm	C mm	A mm	B mm	C mm	A mm	B mm	C mm	A mm	B mm	C mm
80	0.75-1.1 / 0.86-1.27	-1	-1	148									
90	1.5-2.2 / 1.75-2.55	-2	-10	148	-1.5	-1.5	165	-1.5	-1.5	170			
100	3.0 / 3.45	5	0	175	+4.6	0	183	0	0	183			
112	4.0 / 4.6	5	0	175	+4.6	0	183	0	0	183			
132	5.5-7.5 / 5.75-8.6	1	3	196	-2	-2	196	0	+5	210	+1	0	220
160	11.0- 22 12.6-25.3	7	23	256	+7	+15	256	+7	+10	256	0 0	+3 0	256 279
180	22.0/25.3 Sonder				+7	+13	256	+7	+8	256	+1 0	0 0	256 279
200	30.0/33.5				0	+20	256						
200	30.0-37.0/ 33.5-41.5							0	+15	256	+1 0	0 0	256 279
225	45.0/51.0							0	+21	262	0 0	+7 +6	262 285
250	55.0/62.0										+2 -3	+6 -3	295 305
280	75.0-90.0/ 84.0-101										-34 +6	+30 +1	295 320
315	110.0										-3	0	310

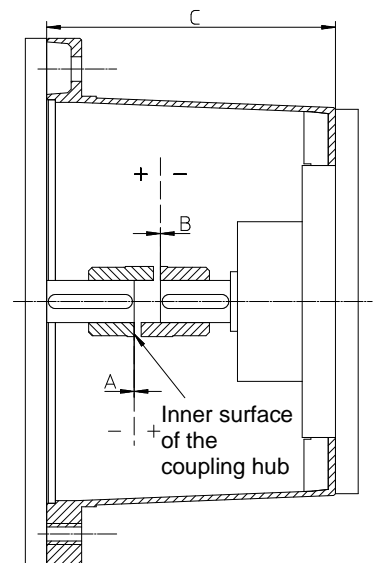

Dim. A: Distance between inner surface of the coupling hub and the motor shaft end

Dim. B: Distance between inner surface of the coupling hub and pump shaft end

+ = Inner surface of the coupling hub is higher as shaft end

- = Inner surface of the coupling hub is lower as shaft end

ATTENTION

High axial impact loads on both pump and motor shafts during the coupling assembly process are to be avoided at all costs in order to prevent any damage to the pump and motor bearings.

11.2 Repairs to the pump

In general, the pumps do not need servicing or maintenance and only need to be sent to the manufacturer in order to be repaired. Upon request, the manufacturer provides training and information sheets on the subject of spindle sets.

12 Disposal

When disposing of the pump or the packaging materials the local and national regulation for proper disposal must be complied with. Prior to its disposal, the pump must be completely drained and decontaminated if necessary.

13 Declarations of conformity

13.1 UK declaration of conformity



UK declaration of conformity

Manufacturer

Brinkmann Pumpen, K. H. Brinkmann GmbH & Co. KG
Friedrichstraße 2
D-58791 Werdohl
Germany

This declaration of conformity is issued under the sole responsibility of Brinkmann Pumps and belongs to the following product.

Product name

High Pressure Pumps

Type **BFS, TFS, FFS, BFS-H, TFS-H, BFG, FFG**

The named product described above complies with the following statutory requirements of United Kingdom:

UK SI 2008 No. 1597 The Supply of Machinery (Safety) Regulations 2008

UK SI 2016 No. 1091 The Electromagnetic Compatibility Regulations 2016

UK SI 2020 No. 1647 The Restriction of the Use of Certain Hazardous Substances in Electrical and Electronic Equipment Regulations 2020

The following exceptions in accordance with table 1, "Table of exempted applications" are claimed: No.12 (6a), No.15 (6b)

The following designated standards and technical specification have been applied:

EN 809:1998+A1:2009+AC:2010

EN ISO 12100:2010

EN 60204-1:2018

EN IEC 61000-3-2 :2019 +A1 :2021

EN 61000-3-3 :2013+A1 :2019 +A2 :2021 +A2 :2021/AC :2022

EN IEC 61000-6-2 :2019

EN IEC 61000-6-3 :2021

EN IEC 63000 :2018

Additionally the following standard has been applied:

EN 60034-1 :2010/AC :2010

The instructions contained in the operating manual for installation and start up the pump have to be followed.

Brinkmann Pumpen, K. H. Brinkmann GmbH & Co. KG

Werdohl, 05.06.2024

.....
Dr.-Ing. Dirk Wenderott
Chief Product Officer (CPO)
Head of Engineering

Dr. H. Abou Dayé

K. H. Brinkmann GmbH & Co. KG
Friedrichstraße 2, D-58791 Werdohl
Representative of documentation



EG-Konformitätserklärung

EC declaration of conformity / Déclaration de conformité CE / Declaración de conformidad CE

Hersteller / Manufacturer / Constructeur / Fabricante

Brinkmann Pumpen, K. H. Brinkmann GmbH & Co. KG
Friedrichstraße 2, D-58791 Werdohl

Produktbezeichnung / Product name / Désignation du produit / Designación del producto

Hochdruckpumpen / High Pressure Pumps / Pompes à haute pression / Bombas de alta presión**Typ / Type / Tipo BFS, TFS, FFS, BFS-H, TFS-H, BFG, FFG**

Das bezeichnete Produkt stimmt mit den folgenden Richtlinien des Rates zur Angleichung der Rechtsvorschriften der EG-Mitgliedsstaaten überein:

The named product conforms to the following Council Directives on approximation of laws of the EEC Member States:
 Le produit sus-mentionné est conforme aux Directives du Conseil concernant le rapprochement des législations des Etats membres CEE:

El producto designado cumple con las Directivas del Consejo relativas a la aproximación de las legislaciones de los Estados Miembros de la CEE:

2006/42/EG	Richtlinie für Maschinen
2006/42/EC	Council Directive for machinery
2006/42/CE	Directive du Conseil pour les machines
2006/42/CE	Directivas del Consejo para máquinas
2014/30/EU	Richtlinie für elektromagnetische Verträglichkeit
2014/30/EU	Council Directive for Electromagnetic compatibility
2014/30/UE	Directive du Conseil pour Compatibilité électromagnétique
2014/30/UE	Directivas del Consejo para Compatibilidad electromagnética
2011/65/EU und 2015/863/EU	RoHS Richtlinien
2011/65/EU and 2015/863/EU	RoHS Directives
2011/65/UE et 2015/863/UE	Directives RoHS
2011/65/UE y 2015/863/UE	RoHS Directivas

Folgende Ausnahmen gem. Anhang III RoHS (2011/65/EU) werden in Anspruch genommen: 6a, 6b.

The following exceptions in accordance with appendix III RoHS (2011/65/ EU) are claimed: 6a, 6b.

Les exceptions suivantes selon l'annexe III RoHS (2011 / 65 / UE) sont revendiquées : 6a, 6b.

Las siguientes excepciones conforme al apéndice III RoHS (2011/65 / UE) son requeridas: 6a, 6b.

Hinsichtlich der elektrischen Gefahren wurden gemäß Anhang I Nr. 1.5.1 der Maschinenrichtlinie 2006/42/EG die Schutzziele der Niederspannungsrichtlinie 2014/35/EU eingehalten.

With respect to potential electrical hazards as stated in appendix I No. 1.5.1 of the machine guide lines 2006/42/EC all safety protection goals are met according to the low voltage guide lines 2014/35/EU.

Conformément à l'annexe I N° 1.5.1 de la Directive "Machines" (2006/42/CE) les objectifs de sécurité relatifs au matériel électrique de la Directive "Basse Tension" 2014/35/UE ont été respectés.

Con respecto al potencial peligro eléctrico como se indica en el apéndice I No. 1.5.1 del manual de la máquina 2006/42/CE, todos los medios de protección de seguridad se encuentran según la guía de bajo voltaje 2014/35/UE.

Die Übereinstimmung mit den Vorschriften dieser Richtlinien wird nachgewiesen durch die vollständige Einhaltung folgender Normen:

Conformity with the requirements of this Directives is testified by complete adherence to the following standards:

La conformité aux prescriptions de ces Directives est démontrée par la conformité intégrale avec les normes suivantes:

La conformidad con las prescripciones de estas directivas queda justificada por haber cumplido totalmente las siguientes normas:

Harmonisierte Europ. Normen / Harmonised Europ. Standards / Normes europ. harmonisées / Normas europ. Armonizadas

EN 809 :1998+A1 :2009+AC :2010 EN ISO 12100 :2010 EN 60204-1 :2018 EN IEC 61000-3-2 :2019 +A1 :2021
EN 61000-3-3 :2013+A1 :2019 +A2 :2021 +A2 :2021/ZAC :2022 EN IEC 61000-6-2 :2019 EN IEC 61000-6-3 :2021
EN IEC 63000 :2018

Nationale Normen / National Standards / Normes nationales / Normas nacionales : **EN 60034-1 :2010/AC :2010**

Die Hinweise in der Betriebsanleitung für den Einbau und die Inbetriebnahme der Pumpe sind zu beachten.

The instructions contained in the operating manual for installation and start up the pump have to be followed.

Les indications d'installation / montage et de mise en service de la pompe prévues dans l'instruction d'emploi doivent être suivies.

Tenga en cuenta las instrucciones en el manual para la instalación y puesta en marcha de la bomba.

Brinkmann Pumpen, K. H. Brinkmann GmbH & Co. KG

Werdohl, 05.06.2024

.....
 Dr.-Ing. Dirk Wenderott
 Chief Product Officer (CPO)
 Head of Engineering

Dr. H. Abou Dayé

K. H. Brinkmann GmbH & Co. KG
 Friedrichstraße 2, D-58791 Werdohl

Dokumentationsbevollmächtigter / Representative of
 documentation/ Mandataire de documentation /
 Mandatario de documentación