

# BE3920 Operating Instructions

(Translation of original)

---

## BRINKMANN Immersion Pumps

### TH/STH2...TH/STH6



**Brinkmann Pumpen**  
**K. H. Brinkmann GmbH & Co. KG**  
Friedrichstraße 2 D-58791 Werdohl  
Tel.: +49-2392 / 5006-0  
Fax.: +49-2392 / 5006-180

[www.brinkmannpumps.de](http://www.brinkmannpumps.de)  
[sales@brinkmannpumps.de](mailto:sales@brinkmannpumps.de)

Subject to change without prior notice.

Order - No.: BE3920 ENGLISH

# Brinkmann Immersions pumps of the series TH/STH2 ... TH/STH6

## Contents

1	Indication to the manual .....	2	9	Trouble shooter's guide.....	12
2	Description of product .....	2	10	Spare part .....	13
3	Safety instructions .....	9	11	Repair .....	14
4	Transport and storage .....	9	12	Disposal .....	15
5	Installation and Connection .....	10	13	Declarations of conformity.....	16
6	Start up / Shut down.....	11			
7	Operation.....	11			
8	Servicing and Maintenance .....	11			

## 1 Indication to the manual

This operating manual gives basic instructions which are to be observed during installation, operation and maintenance of the pump. It is therefore imperative that this manual be read by the responsible personnel and operator prior to assembly and commissioning. It is always to be kept available at the installation site.

### 1.1 Identification of safety instructions in the operating manual

Safety instructions given in this manual non-compliance with which would affect **safety** are identified by the following symbol



Safety sign according with ISO 3864 – B.3.1

or where **electrical safety** is involved, with:



Safety sign according with ISO 3864 – B.3.6

Where non-compliance with the safety instructions may cause a risk to the machine and it's function the word

**ATTENTION**

is inserted.

## 2 Description of product

### 2.1 General description of the pump

Pumps of this type are multi-stage rotary pumps. Series TH/STH use closed impellers in order to minimizing power consumption and to optimize hydraulic pump efficiencies. In addition, the TH/STH series offers high pressures at short immersion depths.

The pump shaft and the motor shaft are connected by a coupling. The pump shaft is sealed by a rotating mechanical seal. The pump is protected again impurity by a filter. Pump and motor form a compact and space-saving unit.

Vertically mounted pumps are equipped with a mounting flange. The pump end immerses into the tank and the motor extends vertically above the tank.

### 2.2 Intended use

The immersion pumps of the series TH/STH have been especially developed to supply internally cooled tools with coolant fluid within the limiting application in accordance with table 1.

Limit of Application (Table 1)

Type	TH/STH2...6
Mediums	Industry water, cooling emulsions, cooling- and cutting-oils
Kinetic viscosity of the medium	1 mm <sup>2</sup> /s higher viscosity upon request
Temperature of medium	0 ... 80 °C
Particle-size in the medium	1 mm
max. operation pressure	27 bar
min. delivery volume 50 / 60 Hz in l/min	(S)TH2 6 / 7 (S)TH4 10 / 12 (S)TH6 20 / 25 at special execution -Q 1% of Q max.
Dry running	The pumps are not suitable for dry running.
Switching-on frequency per hour	Motors less 3 kW max. 200 from 3 kW to 4.0 kW max. 40 from 5.0 kW to 10.3 kW max. 20
Ambient temperature	40 °C
Set-up altitude	1000 m

**ATTENTION**

The pumps are to be operated within their design limits. Applications outside of these limits are not approved. The manufacturer is not responsible for any damages resulting from use of the pumps in such applications.

### 2.3 Type Designation

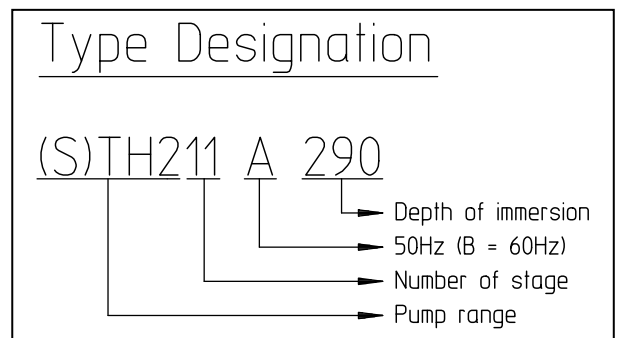

## 2.4 Technical data

### 50 Hz

Type	Max. del. pressure bar / spec. weight 1	Max. del. volume l/min	Height H mm	Depth of immersion h mm	Weight TH <sup>1)</sup> kg	Power kW	Noise level <sup>2)</sup> dBA	
(S)TH203A190	1.9	36	291	190	14.9	0.48	58	
(S)TH204A190	2.2							
(S)TH205A190	2.8							
(S)TH206A190	3.4							
(S)TH207A290	4	38		290	15.7			
(S)TH208A290	4.4							
(S)TH209A290	5.0							
(S)TH210A290	5.8							
(S)TH211A290	6.2	38	332	290	17.4	0.63	58	
(S)TH212A390	6.8				42			390
(S)TH213A390	7.5	42	332	390	20.0	0.75	58	
(S)TH214A390	8.2				20.1			
(S)TH215A390	9.0	42	332	390	21.4	0.92	58	
(S)TH216A390	9.5				21.5			
(S)TH217A490	10.0				490			22.1
(S)TH218A490	10.6				22.2			
(S)TH219A490	11.2	45	359	490	24.1	1.1	58	
(S)TH220A490	11.8				24.2			
(S)TH221A490	12.2				24.3			
(S)TH222A590	12.8				590			24.9
(S)TH223A590	13.7	45	381	590	31.0	1.3	63	
(S)TH224A590	14.1				31.2			
(S)TH225A590	14.8	45	381	590	31.3	1.5	63	
(S)TH226A590	15.5				31.5			
(S)TH227A690	16.0				690			32.4
(S)TH228A690	16.8				32.5			
(S)TH229A690	17.5	45	407	690	34.3	1.7	63	
(S)TH230A690	18				34.4			
(S)TH231A690	18.5				34.5			
(S)TH232A790	19.0				790			36.4
(S)TH233A790	19.6	45	439	790	40.9	1.9	63	
(S)TH234A790	20.2				41.0			
(S)TH235A790	20.8				41.1			
(S)TH236A790	21.5				41.2			
(S)TH237A890	22.0	48	439	890	43.0	2.2	63	
(S)TH238A890	22.6				43.1			
(S)TH239A890	23.2				43.2			
(S)TH240A890	24.0				43.3			
(S)TH241A890	24.5				43.4			

1) Weight STH = Weight TH + 2 kg

2) Noise emissions measured in accordance with  
DIN 45635 at a distance of 1 m.

The motor is surface-cooled and compliant with  
DIN IEC 34 and EN 60034 (protection degree IP 55).

## 50 Hz

Type	Max. del. pressure bar / spec. weight 1	Max. del. volume l/min	Height H mm	Depth of immersion h mm	Weight	Power kW	Noise level <sup>2)</sup> dBA
					TH <sup>1)</sup> kg		
(S)TH403A190	2.0	70	291	190	14.9	0.48	58
(S)TH404A190	2.8				15.0		
(S)TH405A190	3.8				15.1		
(S)TH406A190	4.2	72	332	190	16.5	0.63	58
(S)TH407A290	5.1	75	332	290	17.9	0.75	58
(S)TH408A290	5.9				18.0		
(S)TH409A290	6.6	75	332	290	18.5	0.85	58
(S)TH410A290	7.3	80	332	290	19.0	0.92	58
(S)TH411A290	8.0	80	359	290	20.1	1.1	58
(S)TH412A390	8.8				390		
(S)TH413A390	9.2	80	381	390	27.6	1.3	63
(S)TH414A390	10.1	85	381	390	28.1	1.5	63
(S)TH415A390	11.0				28.2		
(S)TH416A390	11.9	85	407	390	30.9	1.7	63
(S)TH417A490	12.5				490		
(S)TH418A490	13.2	85	439	490	35.6	1.9	63
(S)TH419A490	14.0				35.9		
(S)TH420A490	14.8	85	439	490	36.0	2.2	63
(S)TH421A490	15.6				36.1		
(S)TH422A590	16.2				590		
(S)TH423A590	17.0	90	439	590	37.2	2.6	63
(S)TH424A590	17.8				37.3		
(S)TH425A590	18.6				37.4		
(S)TH426A590	19.2				37.5		
(S)TH427A690	20.0				690		
(S)TH428A690	20.8	90	432	690	50.0	3.0	71
(S)TH429A690	21.7				50.2		
(S)TH430A690	22.4	90	432	690	50.4	3.3	71
(S)TH431A690	23.2				50.6		
(S)TH432A790	24.0				790		
(S)TH433A790	24.8	90	432	790	52.6	4.0	71
(S)TH434A790	25.4				52.7		
(S)TH435A790	26.0				52.8		
(S)TH436A790	27.0				53.0		

1) Weight STH = Weight TH + 2 kg

2) Noise emissions measured in accordance with  
DIN 45635 at a distance of 1 m

The motor is surface-cooled and compliant with  
DIN IEC 34 and EN 60034 (protection degree IP 55).

## 50 Hz

Type	Max. del. pressure bar / spec. weight 1	Max. del. volume l/min	Height H mm	Depth of immersion h mm	Weight TH <sup>1)</sup> kg	Power kW	Noise level <sup>2)</sup> dBA
(S)TH603A190	2.0	140	291	190	15.3	0.48	58
(S)TH604A190	2.8	140	332	190	16.8	0.63	58
(S)TH605A240	3.8	140	332	240	17.8	0.75	58
(S)TH606A240	4.2	140	332	240	18.0	0.92	58
(S)TH607A290	5.2	140	359	290	19.5	1.1	58
(S)TH608A290	6.0	140	381	290	26.2	1.3	63
(S)TH609A340	6.8	140	381	340	26.8	1.5	63
(S)TH610A340	7.6	140			27.0		
(S)TH611A390	8.1	145	407	390	29.5	1.7	63
(S)TH612A390	9.0	150	439	390	34.0	1.9	63
(S)TH613A490	9.8	150	439	490	35.0	2.2	63
(S)TH614A490	10.4				35.2		
(S)TH615A490	11.2				35.5		
(S)TH616A490	12.0	160	439	490	36.3	2.6	63
(S)TH617A590	12.8			590	36.8		
(S)TH618A590	13.2				37.0		
(S)TH619A590	14.1	160	432	590	48.3	3.3	71
(S)TH620A590	15.1				48.5		
(S)TH621A690	16.0			690	49.5		
(S)TH622A690	16.8	170	432	690	50.1	4.0	71
(S)TH623A690	17.6				50.3		
(S)TH624A690	18.1				50.5		
(S)TH625A790	19.0			790	51.2		
(S)TH626A790	19.8				51.4		
(S)TH627A790	20.5	170	462	790	58.8	5.0	71
(S)TH628A790	21.2				59.0		
(S)TH629A890	22.0			890	60.0		
(S)TH630A890	22.8				60.2		
(S)TH631A890	23.5				60.4		
(S)TH632A890	24.2				60.6		

1) Weight STH = Weight TH + 2 kg

2) Noise emissions measured in accordance with  
DIN 45635 at a distance of 1 m

The motor is surface-cooled and compliant with  
DIN IEC 34 and EN 60034 (protection degree IP 55).

## 60 Hz

Type	Max. del. pressure bar / spec. weight 1	Max. del. volume l/min	Height H mm	Depth of immersion h mm	Weight TH <sup>1)</sup> kg	Power kW	Noise level <sup>2)</sup> dBA
(S)TH203B190	2.4	40	291	190	14.9	0.55	61
(S)TH204B190	3.4	42			15.0		
(S)TH205B190	4.1				15.1		
(S)TH206B190	5.1				15.2		
(S)TH207B290	6	45	332	290	18.6	0.725	61
(S)TH208B290	7.0				18.7		
(S)TH209B290	7.8	45	332	290	19.2	0,86	61
(S)TH210B290	8.8	45	332	290	20.1	0.98	61
(S)TH211B290	9.6	48	332	290	20.3	1.06	61
(S)TH212B390	10.2			390	20.4		
(S)TH213B390	11.2				20.5		
(S)TH214B390	12.0	48	359	390	21.7	1.27	61
(S)TH215B390	12.8				21.8		
(S)TH216B390	13.8	50	381	390	28.0	1.49	66
(S)TH217B490	14.5	50	381	490	30.2	1.75	66
(S)TH218B490	15.5				30.3		
(S)TH219B490	16.4				30.4		
(S)TH220B490	17.2	52	407	490	32.5	1.95	66
(S)TH221B490	18.0				32.6		
(S)TH222B590	19.0	55	439	590	37.4	2.18	66
(S)TH223B590	19.9				37.5		
(S)TH224B590	20.8	55	439	590	38.2	2.55	66
(S)TH225B590	21.8				38.4		
(S)TH226B590	22.5				38.5		
(S)TH227B690	23.2			690	39.1		
(S)TH228B690	24.1	55	439	690	40.2	2.94	66
(S)TH229B690	25.0				40.3		
(S)TH230B690	26.0				40.4		
(S)TH231B690	26.5				40.5		

1) Weight STH = Weight TH + 2 kg

2) Noise emissions measured in accordance with  
DIN 45635 at a distance of 1 m

The motor is surface-cooled and compliant with  
DIN IEC 34 and EN 60034 (protection degree IP 55).

## 60 Hz

Type	Max. del. pressure bar / spec. weight 1	Max. del. volume l/min	Height H mm	Depth of immersion h mm	Weight TH <sup>1)</sup> kg	Power kW	Noise level <sup>2)</sup> dBA
(S)TH403B190	3.2	84	291	190	15.4	0.55	61
(S)TH404B190	4.2	84	332	190	16.7	0.725	61
(S)TH405B190	5.3	84	332	190	17.2	0.86	61
(S)TH406B190	6.2	88	332	190	18.2	1.06	61
(S)TH407B290	7.6	88	359	290	19.4	1.27	61
(S)TH408B290	8.3				19.5		
(S)TH409B290	9.5	92	381	290	27.0	1.49	66
(S)TH410B290	10.6	92	381	290	27.2	1.75	66
(S)TH411B290	11.8	95	407	290	29.4	1.95	
(S)TH412B390	12.8			390	30.0		
(S)TH413B390	13.9	95	439	390	35.0	2.18	66
(S)TH414B390	15.0	100	439	390	35.5	2.55	66
(S)TH415B390	16.0				35.6		
(S)TH416B390	17.1	100	439	390	36.0	2.94	66
(S)TH417B490	18.1			490	36.1		
(S)TH418B490	19.2				36.2		
(S)TH419B490	20.2	105	432	490	47.9	3.8	75
(S)TH420B490	21.8				48.0		
(S)TH421B490	22.5				48.1		
(S)TH422B590	23.8			590	48.3		
(S)TH423B590	24.8	105	432	590	49.5	4.55	75
(S)TH424B590	26.0				49.7		

1) Weight STH = Weight TH + 2 kg

2) Noise emissions measured in accordance with  
DIN 45635 at a distance of 1 m

The motor is surface-cooled and compliant with  
DIN IEC 34 and EN 60034 (protection degree IP 55).

## 60 Hz

Type	Max. del. pressure bar / spec. weight 1	Max. del. volume l/min	Height H mm	Depth of immersion h mm	Weight TH <sup>1)</sup> kg	Power kW	Noise level <sup>2)</sup> dBA
(S)TH603B190	3.2	170	332	190	16.8	0.86	61
(S)TH604B190	4.2	170	332	190	17.5	1.06	61
(S)TH605B240	5.2	170	359	240	18.5	1.27	61
(S)TH606B240	6.2	175	381	240	25.0	1.75	66
(S)TH607B290	7.8	175	407	290	29.0	1.95	66
(S)TH608B290	8.4	185	439	290	32.0	2.18	66
(S)TH609B340	9.8	185	439	340	35.0	2.55	66
(S)TH610B340	10.8	195	439	340	36.0	2.94	66
(S)TH611B390	12.0			390	36.6		
(S)TH612B390	13.0	195	432	390	48.0	3.45	75
(S)TH613B490	14.0	195	432	490	49.9	3.8	75
(S)TH614B490	15.2				50.1		
(S)TH615B490	16.2	200	432	490	51.8	4.55	75
(S)TH616B490	17.8				52.3		
(S)TH617B590	18.4			590	52.8		
(S)TH618B590	19.8	200	462	590	56.8	5.75	75
(S)TH619B590	20.8				56.9		
(S)TH620B590	22.0				57.0		
(S)TH621B690	23.0			690	57.2		
(S)TH622B690	24.0				57.3		
(S)TH623B690	25.2	210	462	690	61.0	6.3	75
(S)TH624B690	26.2				61.2		

1) Weight STH = Weight TH + 2 kg

2) Noise emissions measured in accordance with  
DIN 45635 at a distance of 1 m

The motor is surface-cooled and compliant with  
DIN IEC 34 and EN 60034 (protection degree IP 55).



### 3 Safety instructions

When operating the pump, the safety instructions contained in this manual, the relevant national accident prevention regulations and any other service and safety instructions issued by the plant operator are to be observed.

#### 3.1 Hazards in the event of non-compliance with the safety instructions

Non-compliance with the safety instructions may produce a risk to the personnel as well as to the environment and the machine and results in a loss of any right to claim damages.

For example, non-compliance may involve the following hazards:

- Failure of important functions of the machines/plant
- Failure of specified procedures of maintenance and repair
- Exposure of people to electrical, mechanical and chemical hazards
- Endangering the environment due to hazardous substances being released

#### 3.2 Unauthorized modes of operation



- Pump may not be used in potentially explosive environments!
- Pump and discharge piping are not designed to hold any weight and may not be used as a step ladder.

#### 3.3 Remaining Risk



##### **Risk of Injury!**

Risk of squeezing or crushing body parts when installing or removing the pump exists. Proper and secured lifting tools must be used.

##### **Risk of burns!**

The pump must have cooled down sufficiently prior to commencing any repair, maintenance or installation.

#### 3.4 Qualification and training of operating personnel

The personnel responsible for operation, maintenance, inspection and assembly must be adequately qualified. Scope of responsibility and supervision of the personnel must be exactly defined by the plant operator. If the staff does not have the necessary knowledge, they must be trained and instructed, which may be performed by the machine manufacturer or supplier on behalf of the plant operator. Moreover, the plant operator is to make sure that the contents of the operating manual are fully understood by the personnel.

#### 3.5 Safety instructions relevant for operation

- If hot or cold machine components involve hazards, they must be guarded against accidental contact.
- Guards for moving parts (e.g. coupling) must not be removed from the machine while in operation.
- Any leakage of hazardous (e.g. explosive, toxic, hot) fluids (e.g. from the shaft seal) must be drained away so as to prevent any risk to persons or the environment. Statutory regulations are to be complied with.
- Hazards resulting from electricity are to be prevented (see for example, the VDE Specifications and the bye-laws of the local power supply utilities).
- The pumps' stability against falling over is not ensured unless it is properly mounted onto the tank.
- The female threads on the motor **MUST NOT** be used to lift the entire pump and motor assembly.

#### 3.6 Safety instructions relevant for maintenance, inspection and assembly work

Any work on the machine shall only be performed when it is at a standstill, it being imperative that the procedure for shutting down the machine described in this manual be followed.

Pumps and pump units which convey hazardous media must be decontaminated.

On completion of work all safety and protective facilities must be re-installed and made operative again.

Prior to restarting the machine, the instructions listed under "Start up" are to be observed.

#### 3.7 Signs on the pump

It is imperative that signs affixed to the machine, e.g.:

- arrow indicating the direction of rotation
- symbols indicating fluid connections be observed and kept legible.

#### 3.8 Unauthorized alterations and production of spare parts

Any modification may be made to the machine only after consultation with the manufacturer. Using spare parts and accessories authorized by the manufacturer is in the interest of safety. Use of other parts may exempt the manufacturer from any liability.

### 4 Transport and storage

Protect the pump against damage when transporting.

The pumps may only be transported in a horizontal position and hooks or straps must be attached on the motor and pump end.

Do not use the pump shaft for connecting any transportation aids such as hooks or straps.

Pumps must be drained prior to their storage.

Store pump in dry and protected areas and protect it against penetration of foreign bodies.

Always store pump above the freezing point!

## 5 Installation and Connection

### 5.1 Mechanical installation

During any assembly or disassembly process the pumps must be secured against tipping through ropes for example at all times.

Pumps must be mounted securely. Piping, tank and pumps must be mounted without any tension.

The inlet is at the bottom of the immersed pump body. The distance between the inlet and the tank bottom must be so large that the inlet cannot be blocked by deposits during longer shutdowns.

The leakage is collected in a leakage chamber and drained off by the leakage hole into the tank. During the assembling of the pump, be sure that the leakage hole is free.

To obtain the full flow rate it is recommended to choose for the pipework the nominal bore diameter of the pumps cross section for connection. Therefore pipe bends should be used, not pipe angles!

The pipework must be qualified for occurring hydraulic pressure.

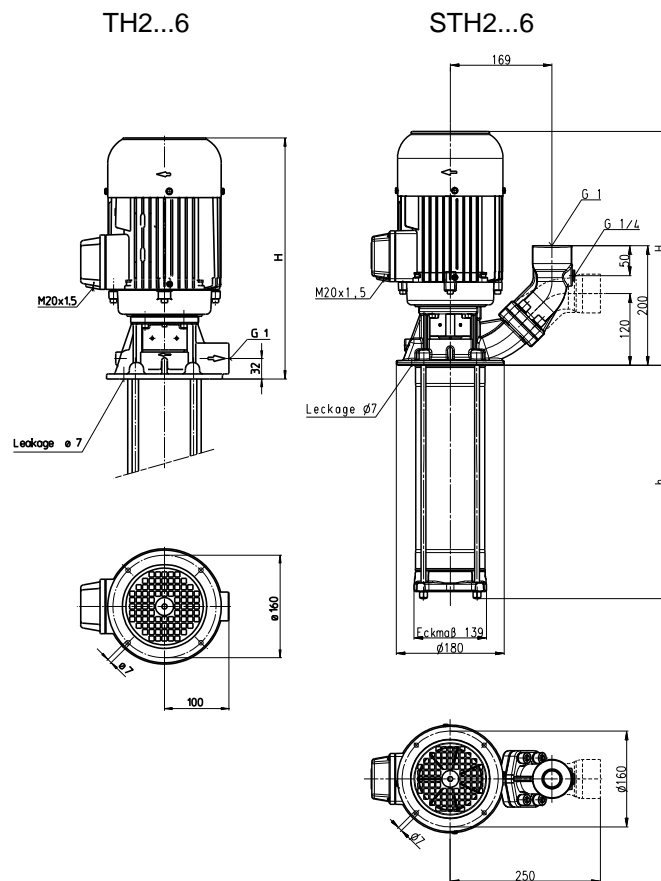

### ATTENTION

**Pay attention of the max. tightening torque for piping connection**

Type	Pipe connection	Cast iron	Brass
TH2...6	G 1	90 Nm	50 Nm
STH2...6	G 1	90 Nm	-

**When installed the space around the pump must be large enough to provide sufficient cooling of the motor.**

**Do not prop up the pressure line via the joining socket.**



**The pump must be mounted in that way that rotating parts under the cover of the coolant tank can not be touched!**

### 5.2 Electric wiring



**All service work must be carried out by qualified service personnel. Pump must be disconnected from the power source and all rotating parts must stand still. Reassure that pump is disconnected from power source and cannot be switched on. Verify that there is no voltage at the terminal board!**

According to the European Standard EN809 a motor overload must be installed and properly set to the full load amps stated on the pump name plate.

It is the responsibility of the machine operator to decide whether or not an additional emergency switch must be installed.



**Danger!**

#### Risk of electric shock

Our asynchronous motors can optionally be fitted with temperature sensors in the form of triplet PTC thermistors, which are used for thermal monitoring of the motor windings. Please note that the temperature sensors meet the insulation requirements of basic insulation. The improper connection of the triplet PTC thermistors to evaluation units that do not have a protective function against overvoltage in the event of a fault can lead to voltages dangerous to the touch and electric shock.

Please check whether the evaluation units you intend to use are permissible for the electrical connection of the temperature sensors.

#### 5.2.1 Circuit



Tension voltage and frequency must correspond with the shown specification on the nameplate.

The pump must be wired so that a solid long term electrical connection is ensured. Establish a solid ground connection.

**The electrical wiring must be performed according to the wiring diagram shown inside the terminal box cover. (Please see above sample wiring diagrams)**

## Wiring diagram e.g.

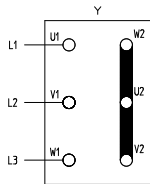

**Star connection**  
3 x 400 V, 50 Hz  
resp. 380-415 V, 50 Hz

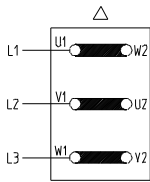

**Delta connection**  
3 x 230 V, 50 Hz  
resp. 220-240 V, 50 Hz

There may be no foreign objects such as dirt, particles or humidity inside the terminal board.

Mount terminal board cover to motor tight against dust and humidity and close up all unused wiring ports.

### ATTENTION

When Variable Frequency Drives are used interfering signals might occur.

Non-sinus shaped supply voltage from a variable frequency drive might result in elevated motor temperatures.

## 6 Start up / Shut down

### 6.1 Start up

### ATTENTION

Switch off at the mains.

After connection the electrical wires, close the terminal box. Briefly start the motor (max. 30 sec.) and check the rotation according to the arrow on the top of the motor.

If the direction is incorrect change over two of the power leads.

### 6.2 Shut down

All service work must be carried out by qualified service personnel. Pump must be disconnected from the power source and all rotating parts must stand still. Reassure that pump is disconnected from power source and cannot be switched on. Verify that there is no voltage at the terminal board! Open terminal box and disconnect the power leads. Empty out the pump.

## 7 Operation

### Liquid level

Be sure that the suction hole of the pump body is immersed about 46 mm in the liquid (min. liquid level) before starting up the motor.

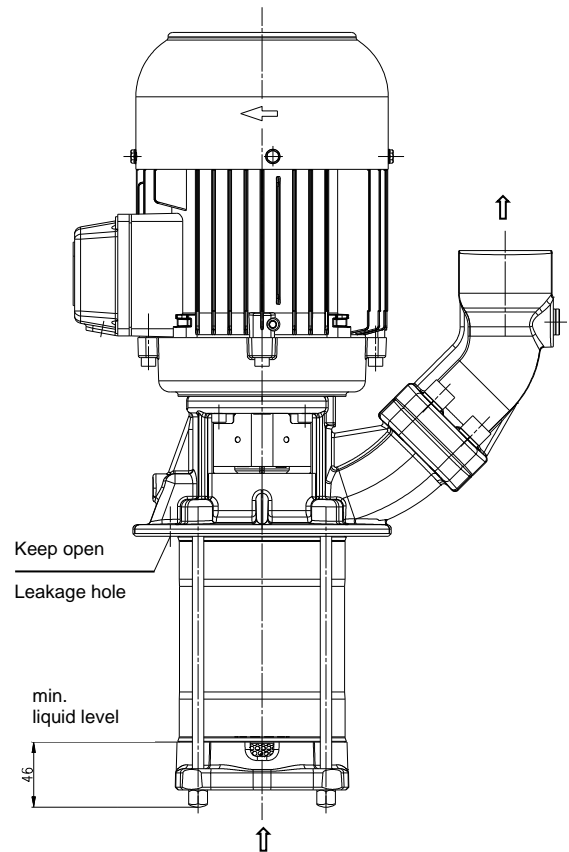

If the pump should lock up and cease, shut pump down (see 6.2) and disconnect from power supply. Pump must be uninstalled and removed from the system prior to its repair.

## 8 Servicing and Maintenance

### ATTENTION

The surface of the motor must be kept free of dirt.

The motor shaft is spinning in permanently greased ball bearings (with special grease and increased bearing play) and does not require any special maintenance.

## 9 Trouble shooter's guide

Fault	Cause	Remedy
Motor does not start, no motor noise	At least two of the power supply leads have failed	Check fuses, terminals and supply leads .
	Overload has tripped	Inspect overload
Motor does not start, humming noise	One of the supply leads has failed	See above
	Impeller faulty Motor bearing faulty	Replace impeller Replace bearing
Overload trips	Pump locked up mechanically	Inspect pump hydraulics
	High on/of cycling frequency	Check application
Power consumption is too high	Wrong direction of rotation of impeller	See above
	Lime or other deposits mechanical friction	Clean pump mechanism repair pump
Motor overheats	High on/off cycling frequency	See above
	Wrong power supply (voltage or cycles)	Power supply must correspond with name plate rating
Pump does not pump	Insufficient cooling	Check air flow at motor fan
	liquid level too low Pump mechanism faulty Pipe blocked	Fill up liquid replace pump mechanism Clean pipe
Insufficient flow and pressure	Wrong direction of rotation of impeller	Change over two power supply leads
	Pump mechanism silted up Worn pump mechanism	Clean pump mechanism Replace pump mechanism
Incorrect flow or pressure	Wrong power supply (voltage or cycles)	Power supply must correspond with name plate rating
Running noise/Vibration	Foreign objects in pump end	Remove foreign objects
	Impeller damaged	Replace impeller
	Bearing/Bushing broken	Replace bearing/bushing

## 10 Spare part

### 10.1 Spare part list for the immersion pumps of the series TH/STH2 ... 6

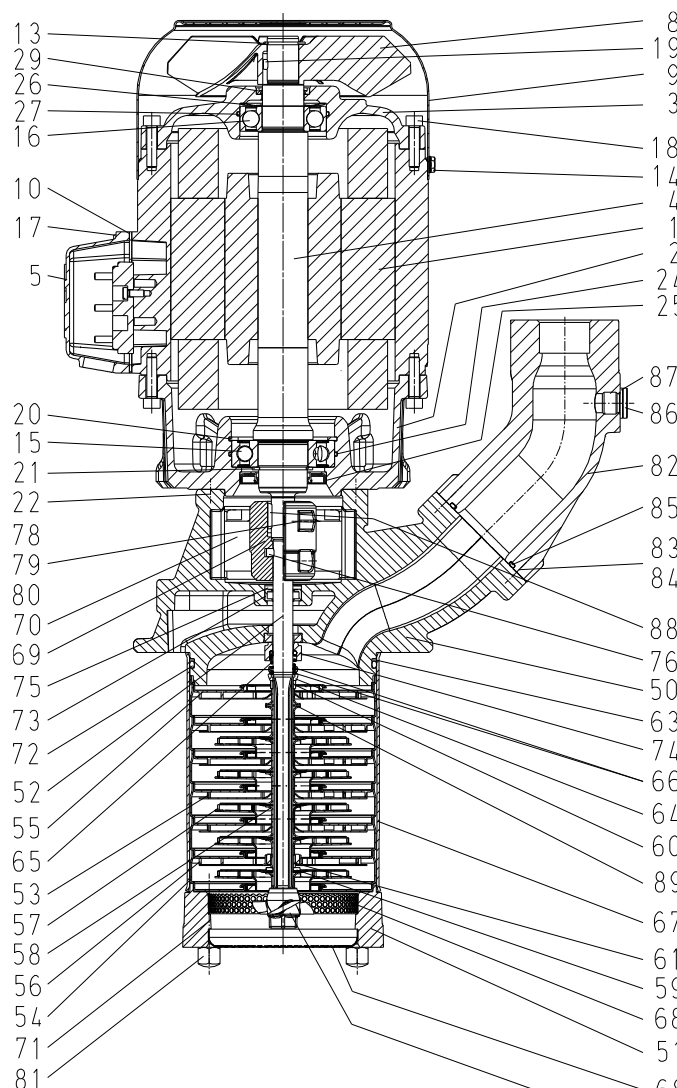

Item	Description	
1	Stator with terminal board	
2	Motor flange	
3	End shield	
4	Motor shaft with rotor	
5	Terminal box	
8	Fan	
9	Fan cover	
10	Gasket	
13	Retaining ring	
13	Retaining ring 1.3...2.6 kW	DIN 471
14	Thread rolling screw from 1.3 kW and over	DIN 7500
15	Ball bearing	DIN 625
15	Ball bearing 1.3...2.6 kW	DIN 628
16	Ball bearing	DIN 625
17	Slotted cheese head screw	DIN 84
18	Stud bolt with bond up to 1.1 kW	
18	Hexagon socket head cap screw from 1.3 kW and over	DIN 912
19	Parallel pin	DIN 7
20	Retaining ring	DIN 472
21	Retaining ring	DIN 471
22	Socket head cap screw	DIN 912
24	O-ring from 1.3 kW and over	
25	Rotary shaft seal from 0.75 kW and over	
26	Compensation disk from 1.3 kW and over	
27	O-ring from 1.3 kW and over	
29	Rotary shaft seal	
50	Pump body	
51	Intake cover	
52	Pump shaft	
53	Diffusor with sliding ring	
54	Entering stage with sliding ring	
55	Outflow stage (S)TH2...(S)TH4	
56	Bearing stage with sliding ring	
57	Impeller	
58	Spacer-long 2 x per stage	
59	Spacer-short 1 x per bearing stage	
60	Sliding ring	
61	Shaft sleeve	
63	Spiral backup ring	
64	Mech. seal stop ring cover	
65	Mech. seal stop half-ring	
66	Mech. seal washer up to (S)TH221A (S)TH421A and (S)TH616A (S)TH216B, (S)TH414B and (S)TH614B	
66	Mech. seal stop ring from (S)TH222A (S)TH422A and (S)TH617A (S)TH217B, (S)TH415B and (S)TH615B	
67	Pump casing	
68	Sieve	
69	Clamp coupling	
70	Coupling shield with M5 screw	
71	Stud bolt	
72	O-ring	
73	Rotary shaft seal	
74	Mechanical seal	
75	Retaining ring	
76	Parallel pin	DIN 7
77	Suction screw	
78	Hexagon socket head cap screw	DIN 912
79	Serrated lock washer	DIN 6798
80	Hexagon nut	DIN 934
81	Hexagon cap nuts	DIN 917
82	Joining socket STH	
83	Socket head cap screw STH	DIN 912
84	Spring washer STH	DIN 7980
85	O-ring STH	
86	Screw plug STH	DIN 908
87	Sealing ring STH	DIN 7603
88	Woodruff key	DIN 6888
89	Distance plate instead of impeller at empty stage for special depth of immersion	

## 10.2 Indications to the spare part order

Spare parts are available from the supplier. Standard commercially available parts are to be purchased in accordance with the model type. The ordering of spare parts should contain the following details:

### 1. Pumptype

e.g. TH204A190

### 2. Pump No.

e.g. 06243920

The date of the construction year is a component of the pumps type number.

### 3. Voltage. Frequency and Power

Take item 1, 2 and 3 from the nameplate

### 4. Spare part with item No.

e.g. Impeller item No. 57

## 11 Repair

### 11.1 Exchange the rotary mechanical seal: up to (S)TH221A, (S)TH421A, (S)TH616A (S)TH216B, (S)TH414B, (S)TH614B

- 1) Disconnect the pump from the power supply.
- 2) Loosen the M5 screws and pull out coupling shield (70). Remove clamp coupling (69.1. 69.2) and parallel pin (76).
- 3) Loosen and pull off the hexagon cap nuts (81), the stud bolt (71) and the pump casing (67) from the pump unit. Remove pump unit with pump shaft (52) from the pump body (50).
- 4) Take off rotating axial face seal unit (74.1-74.5) and mech. seal washer (66) from the shaft (52) and clean the shaft. Pay attention to the drilled hole for the parallel pin (76) that it is without any bur. Check the sliding surface for the rotary shaft seal (73) for any damage.
- 5) Remove complete seal (74.6. 74.7) from the pump body (50) and clean the seat.
- 6) Mounting of the new axial face seal :  
Ensure that the sliding surfaces of the ring and the rotating axial face seal unit are free from grease and dirt.  
Moisten the angle-sleeve (74.7) of the counter ring lightly with rinse water / ( water with washing-up liquid ) and push the unit into the seat of the pump body (50).  
Slide the mech. seal washer (66) first and then the axial face seal (74.1-74.5) onto the pump shaft (52).
- 7) Lubricate lightly the lip of the rotary shaft seal (73) and push it into the pump body (50). Then insert the pump shaft (52) with the pump unit through the rotary shaft seal (73).
- 8) Fit together the coupling clamp (69) with the parallel pin (76) around the shafts, tighten the hexagon socket head cap screws (78) with the serrated lock washer (79) lightly.  
Be sure that the key of the motor shaft (4) coincides with the key groove of the coupling clamp(69.1). Press the pump shaft (52) toward the motor and tighten the screws.  
The distance between the two shaft ends **must be zero**.

- 9) Lubricate the O-ring seal (72) of the pump body (50), screw and put on the stud bolt (71), the hexagon cap nuts (81) and the pump casing (67).
- 10) Fit the coupling shield (70) into the pump body (50) and tighten the M5 screws.
- 11) Reconnect pump to the power supply.

### Check direction of rotation!

### Tightening torques for screwed connections

Thread - Ø	M4	M5	M6	M8	M10
Strength classes	4.8	4.8	8.8	8.8	8.8
Tightening torque (Nm)	1 Nm	3 Nm	4.5 Nm 20 Nm Clamp coupling	15 Nm 30 Nm Clamp coupling	30 Nm

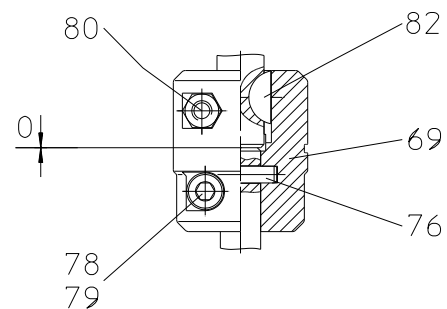
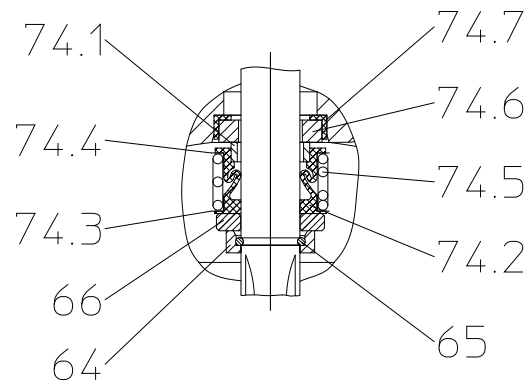

## 11.2 Exchange the rotary mechanical seal: from (S)TH222A, (S)TH422A , (S)TH617A (S)TH217B, (S)TH415B , (S)TH615B

- 1) Disconnect the pump from the power supply.
- 2) Loosen the M5 screws and pull out coupling shield (70). Remove clamp coupling (69.1. 69.2) and parallel pin (76).
- 3) Loosen and pull off the hexagon cap nuts (81), the stud bolt (71) and the pump casing (67) from the pump unit. Remove pump unit with pump shaft (52) from the pump body (50).
- 4) Take off rotating axial face seal unit (74.1-74.5) and mech. seal stop ring (66) from the shaft (52) and clean the shaft. Pay attention to the drilled hole for the parallel pin (76) that it is without any bur. Check the sliding surface for the rotary shaft seal (73) for any damage.
- 5) Remove complete seal (74.6. 74.7) from the pump body (50) and clean the seat.
- 6) Mounting of the new axial face seal :  
Ensure that the sliding surfaces of the ring and the rotating axial face seal unit are free from grease and dirt.  
Moisten the angle-sleeve (74.7) of the counter ring lightly with rinse water / ( water with washing-up liquid ) and push the unit into the seat of the pump body (50).  
Slide the mech. seal stop ring (66) first and then the axial face seal (74.5-74.1) (**single part**) onto the pump shaft (52).
- 7) Lubricate lightly the lip of the rotary shaft seal (73) and push it into the pump body (50). Then insert the pump shaft (52) with the pump unit through the rotary shaft seal (73).
- 8) Fit together the coupling clamp (69) with the parallel pin (76) around the shafts, tighten the hexagon socket head cap screws (78) with the serrated lock washer (79) lightly.  
Be sure that the key of the motor shaft (4) coincides with the key groove of the coupling clamp(69.1).  
Press the pump shaft (52) toward the motor and tighten the screws.  
The distance between the two shaft ends **must be zero**
- 9) Lubricate the O-ring seal (72) of the pump body (50), screw and put on the stud bolt (71), the hexagon cap nuts (81) and the pump casing (67).
- 10) Fit the coupling shield (70) into the pump body (50) and tighten the M5 screws.
- 11) Reconnect pump to the power supply.

## Tightening torques for screwed connections

Thread - Ø	M4	M5	M6	M8	M10
Strength classes	4.8	4.8	8.8	8.8	8.8
Tightening torque (Nm)	1 Nm	3 Nm	4.5 Nm 20 Nm Clamp coupling	15 Nm 30 Nm Clamp coupling	30 Nm

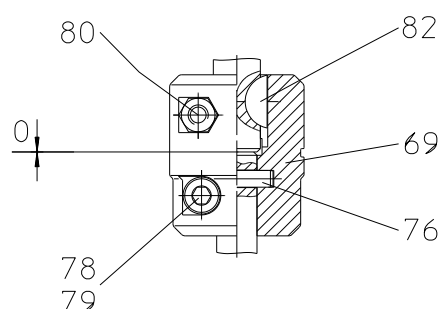
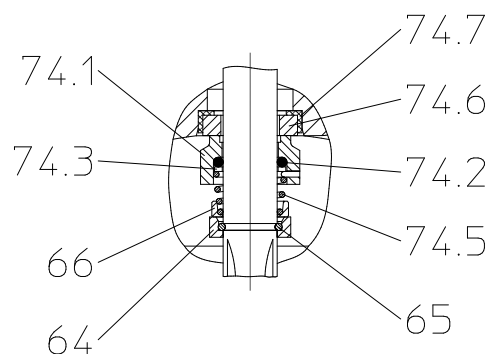

## 12 Disposal

When disposing of the pump or the packaging materials the local and national regulation for proper disposal must be complied with. Prior to its disposal, the pump must be completely drained and decontaminated if necessary.

**Check direction of rotation!**

## 13 Declarations of conformity

### 13.1 UK declaration of conformity



## UK declaration of conformity

Manufacturer

**Brinkmann Pumpen, K. H. Brinkmann GmbH & Co. KG**  
Friedrichstraße 2  
D-58791 Werdohl  
Germany

This declaration of conformity is issued under the sole responsibility of Brinkmann Pumps and belongs to the following product.

Product name

**Immersion pumps**

Type            **TH/STH2 ... 6**

The named product described above complies with the following statutory requirements of United Kingdom:

**UK SI 2008 No. 1597      The Supply of Machinery (Safety) Regulations 2008**

**UK SI 2016 No. 1091      The Electromagnetic Compatibility Regulations 2016**

**UK SI 2020 No. 1647      The Restriction of the Use of Certain Hazardous Substances in Electrical and Electronic Equipment Regulations 2020**

**The following exceptions in accordance with table 1, "Table of exempted applications" are claimed: No.12 (6a), No.15 (6b), No. 18 (6c)**

The following designated standards and technical specification have been applied:

**EN 809:1998+A1:2009+AC:2010**

**EN ISO 12100:2010**

**EN 60204-1:2018**

**EN IEC 61000-3-2 :2019 +A1 :2021**

**EN 61000-3-3 :2013+A1 :2019 +A2 :2021 +A2 :2021/AC :2022**

**EN IEC 61000-6-2 :2019**

**EN IEC 61000-6-3 :2021**

**EN IEC 63000 :2018**

Additionally the following standard has been applied:

**EN 60034-1 :2010/AC :2010**

**The instructions contained in the operating manual for installation and start up the pump have to be followed.**

**Brinkmann Pumpen, K. H. Brinkmann GmbH & Co.  
KG**

Werdohl, 04.06.2024

.....  
Dr.-Ing. Dirk Wenderott  
Chief Product Officer (CPO)  
Head of Engineering

Dr. H. Abou Dayé  
K. H. Brinkmann GmbH & Co. KG  
Friedrichstraße 2, D-58791 Werdohl  
Representative of documentation



## 13.2 EC declaration of conformity

DEUTSCH / ENGLISH / FRANÇAIS / ESPAÑOL



### EG-Konformitätserklärung

#### EC declaration of conformity / Déclaration de conformité CE / Declaración de conformidad CE

Hersteller / Manufacturer / Constructeur / Fabricante

**Brinkmann Pumpen, K. H. Brinkmann GmbH & Co. KG**  
**Friedrichstraße 2, D-58791 Werdohl**

Produktbezeichnung / Product name / Désignation du produit / Designación del producto

**Tauchpumpen / Immersion pumps / Pompes plongeantes / Bombas de inmersión**

**Typ / Type / Tipo TH/STH2 ... 6**

Das bezeichnete Produkt stimmt mit den folgenden Richtlinien des Rates zur Angleichung der Rechtsvorschriften der EG-Mitgliedsstaaten überein:

The named product conforms to the following Council Directives on approximation of laws of the EEC Member States:

Le produit sus-mentionné est conforme aux Directives du Conseil concernant le rapprochement des législations des Etats membres CEE:

El producto designado cumple con las Directivas del Consejo relativas a la aproximación de las legislaciones de los Estados Miembros de la CEE:

**2006/42/EG** Richtlinie für Maschinen  
**2006/42/EC** Council Directive for machinery  
**2006/42/CE** Directive du Conseil pour les machines  
**2006/42/CE** Directivas del Consejo para máquinas

**2014/30/EU** Richtlinie für elektromagnetische Verträglichkeit  
**2014/30/EU** Council Directive for Electromagnetic compatibility  
**2014/30/UE** Directive du Conseil pour Compatibilité électromagnétique  
**2014/30/UE** Directivas del Consejo para Compatibilidad electromagnética

**2011/65/EU und 2015/863/EU** RoHS Richtlinien  
**2011/65/EU and 2015/863/EU** RoHS Directives  
**2011/65/UE et 2015/863/UE** Directives RoHS  
**2011/65/UE y 2015/863/UE** RoHS Directivas

Folgende Ausnahmen gem. Anhang III RoHS (2011/65/EU) werden in Anspruch genommen: 6a, 6b, 6c.

The following exceptions in accordance with appendix III RoHS (2011/65/ EU) are claimed: 6a, 6b, 6c.

Les exceptions suivantes selon l'annexe III RoHS (2011 / 65 / UE) sont revendiquées : 6a, 6b, 6c.

Las siguientes excepciones conforme al apéndice III RoHS (2011/65 / UE) son requeridas: 6a, 6b, 6c.

Hinsichtlich der elektrischen Gefahren wurden gemäß Anhang I Nr. 1.5.1 der Maschinenrichtlinie 2006/42/EG die Schutzziele der Niederspannungsrichtlinie 2014/35/EU eingehalten.

With respect to potential electrical hazards as stated in appendix I No. 1.5.1 of the machine guide lines 2006/42/EC all safety protection goals are met according to the low voltage guide lines 2014/35/EU.

Conformément à l'annexe I N° 1.5.1 de la Directive "Machines" (2006/42/CE) les objectifs de sécurité relatifs au matériel électrique de la Directive "Basse Tension" 2014/35/UE ont été respectés.

Con respecto al potencial peligro eléctrico como se indica en el apéndice I No. 1.5.1 del manual de la máquina 2006/42/CE, todos los medios de protección de seguridad se encuentran según la guía de bajo voltaje 2014/35/UE.

Die Übereinstimmung mit den Vorschriften dieser Richtlinien wird nachgewiesen durch die vollständige Einhaltung folgender Normen:

Conformity with the requirements of this Directives is testified by complete adherence to the following standards:

La conformité aux prescriptions de ces Directives est démontrée par la conformité intégrale avec les normes suivantes:

La conformidad con las prescripciones de estas directivas queda justificada por haber cumplido totalmente las siguientes normas:

Harmonisierte Europ. Normen / Harmonised Europ. Standards / Normes europ. harmonisées / Normas europ. Armonizadas

**EN 809 :1998+A1 :2009+AC :2010 EN ISO 12100 :2010 EN 60204-1 :2018 EN IEC 61000-3-2 :2019 +A1 :2021**  
**EN 61000-3-3 :2013+A1 :2019 +A2 :2021 +A2 :2021/ZAC :2022 EN IEC 61000-6-2 :2019 EN IEC 61000-6-3 :2021**  
**EN IEC 63000 :2018**

Nationale Normen / National Standards / Normes nationales / Normas nacionales : **EN 60034-1 :2010/AC :2010**

**Die Hinweise in der Betriebsanleitung für den Einbau und die Inbetriebnahme der Pumpe sind zu beachten.**

**The instructions contained in the operating manual for installation and start up the pump have to be followed.**

**Les indications d'installation / montage et de mise en service de la pompe prévues dans l'instruction d'emploi doivent être suivies.**

**Tenga en cuenta las instrucciones en el manual para la instalación y puesta en marcha de la bomba.**

**Brinkmann Pumpen, K. H. Brinkmann GmbH & Co. KG**

Werdohl, 04.06.2024

Dr.-Ing. Dirk Wenderott  
Chief Product Officer (CPO)  
Head of Engineering

Dr. H. Abou Dayé  
K. H. Brinkmann GmbH & Co. KG  
Friedrichstraße 2, D-58791 Werdohl  
Dokumentationsbevollmächtigter / Representative of  
documentation/ Mandataire de documentation /  
Mandatario de documentación