

BRINKMANN Immersion Pumps

STA/SAL301...306



Brinkmann Pumpen
K. H. Brinkmann GmbH & Co. KG
Friedrichstraße 2 D-58791 Werdohl
Tel.: +49-2392 / 5006-0
Fax.: +49-2392 / 5006-180

www.brinkmannpumps.de
sales@brinkmannpumps.de

Subject to change without prior notice.

Order - No.: BE2210 ENGLISH

Contents

1 Indication to the manual2	9 Trouble shooter's guide..... 7
2 Description of product2	10 Spare part 8
3 Safety instructions4	11 Repair 9
4 Transport and storage5	12 Disposal 9
5 Installation and connection5	13 Declarations of conformity..... 10
6 Start up / Shut down6	
7 Operation.....6	
8 Servicing and Maintenance7	

1 Indication to the manual

This operating manual gives basic instructions which are to be observed during installation, operation and maintenance of the pump. It is therefore imperative that this manual be read by the responsible personnel and operator prior to assembly and commissioning. It is always to be kept available at the installation site.

1.1 Identification of safety instructions in the operating manual

Safety instructions given in this manual non-compliance with which would affect **safety** are identified by the following symbol



Safety sign according with ISO 3864 – B.3.1

or where **electrical safety** is involved, with:



Safety sign according with ISO 3864 – B.3.6

Where non-compliance with the safety instructions may cause a risk to the machine and it's function the word

ATTENTION

is inserted.

2 Description of product

2.1 General description of the pump

Pumps of this type are one or multi-stage rotary pumps where the impellers are fixed on the driving shaft extension. The pump shaft and motor shaft are interconnected by means of a shaft clamp. Pump and motor form a compact and space-saving unit. These pumps are fitted out with semi-open impellers, (and a suction screw SAL construction).

Vertically mounted pumps are equipped with a mounting flange. The pump end immerses into the tank and the motor extends vertically above the tank.

2.2 Intended use

The immersion pumps of the series STA/SAL are suitable for handling contaminated coolants within the limiting application in accordance with table 1. The pumps of SAL are suitable for handling extremely inflated fluids.

Limit of Application (Table 1)

Type	STA301...306	SAL301...306
Mediums	Cooling emulsions, cooling- and cutting-oils	
Kinetic viscosity of the medium	...45 mm ² /s	...45 mm ² /s
Temperature of medium	0 ... 80 °C	0 ... 80 °C
Particle-size in the medium	7 mm STA/SAL301...306	
min. delivery volume	1% of Q max.	
Dry running	Dry running causes increased wear and should be avoided. During the test of the direction of rotation (< 30 s) permissible.	
Switching-on frequency per hour	Motors less 3 kW	max. 200
Ambient temperature	40 °C	
Set-up altitude	1000 m	

ATTENTION

The pumps are to be operated within their design limits. Applications outside of these limits are not approved. The manufacturer is not responsible for any damages resulting from use of the pumps in such applications.

2.3 Technical data

Type	Type	Max. del. pressure bar / spec. weight 1	Max. del. volume l/min	Height ¹⁾ H mm	Depth of immersion STA ^{1, 2)} h mm	Weight STA SAL g kg	Power 50 / 60 Hz kW	Noise level STA ³⁾ dBA / 50 Hz
STA301 / 120 / 200 / 270 / 350 / 440 / 550	SAL301 / 140 / 220 / 290 / 370 / 460 / 570	1.2	240	334	120 200 270 350 440 550	20.5 22 21.5 23 22.5 24 23.5 25 25.0 27 26.5 31	STA: 0.63 / 0.725 SAL: 0.75 / 0.86	60
STA302 / 170 / 250 / 320 / 400 / 490 / 600	SAL302 / 190 / 270 / 340 / 420 / 510 / 620	2.2	240	361	170 250 320 400 490 600	26 26.5 27 27.5 28 28.5 29 30.0 31 31.5 33 33.5	1.1 / 1.27	60
STA303 / 220 / 300 / 370 / 450 / 540 / 650 / 850 /1000	SAL303 / 240 / 320 / 390 / 470 / 560 / 670 / 870 /1020	3.4	245	380	220 300 370 450 540 650 850 1000	36 37 37 38 38 39 39 40 40 41 42 43 48 49 50 51	1.5 / 1.75	66
STA304 / 270 / 350 / 420 / 500 / 590 / 700 / 900 /1050	SAL304 / 290 / 370 / 440 / 520 / 610 / 720 / 920 /1070	4.5	245	439	270 350 420 500 590 700 900 1050	45 46 46 47 47 48 49 50 50 51 52 53 58 59 60 61	1.9 / 2.18	66
STA305 / 320 / 400 / 470 / 550 / 640 / 750 / 950 /1100	SAL305 / 340 / 420 / 490 / 570 / 660 / 770 / 970 /1120	5.6	250	439	320 400 470 550 640 750 950 1100	50 51 51 52 52 53 53 54 54 55 56 57 63 64 65 66	2.6 / 2.94	66
STA306 / 370 / 450 / 520 / 600 / 690 / 800 /1000	SAL306 / 390 / 470 / 540 / 620 / 710 / 820 /1020	6.9	255	478	370 450 520 600 690 800 1000	63 64 64 65 65 66 66 67 67 68 69 70 76 77	3.3 / 3.8	71

1) Dimensions in accordance with page 5

2) **Depth of immersion SAL = h + 20 mm**

3) Noise emissions measured in accordance with DIN 45635 at a distance of 1 m

The motor is surface-cooled and compliant with
DIN IEC 34 and EN 60034 (protection degree IP 55).

3 Safety instructions

When operating the pump, the safety instructions contained in this manual, the relevant national accident prevention regulations and any other service and safety instructions issued by the plant operator are to be observed.

3.1 Hazards in the event of non-compliance with the safety instructions

Non-compliance with the safety instructions may produce a risk to the personnel as well as to the environment and the machine and results in a loss of any right to claim damages.

For example, non-compliance may involve the following hazards:

- Failure of important functions of the machines/plant
- Failure of specified procedures of maintenance and repair
- Exposure of people to electrical, mechanical and chemical hazards
- Endangering the environment due to hazardous substances being released

3.2 Unauthorized modes of operation



- Pump may not be used in potentially explosive environments!
- Pump and discharge piping are not designed to hold any weight and may not be used as a step ladder.

3.3 Remaining Risk



Risk of Injury!

Risk of squeezing or crushing body parts when installing or removing the pump exists. Proper and secured lifting tools must be used.

Risk of burns!

The pump must have cooled down sufficiently prior to commencing any repair, maintenance or installation.

3.4 Qualification and training of operating personnel

The personnel responsible for operation, maintenance, inspection and assembly must be adequately qualified. Scope of responsibility and supervision of the personnel must be exactly defined by the plant operator. If the staff does not have the necessary knowledge, they must be trained and instructed, which may be performed by the machine manufacturer or supplier on behalf of the plant operator. Moreover, the plant operator is to make sure that the contents of the operating manual are fully understood by the personnel.

3.5 Safety instructions relevant for operation

- If hot or cold machine components involve hazards, they must be guarded against accidental contact.
- Guards for moving parts (e.g. coupling) must not be removed from the machine while in operation.
- Any leakage of hazardous (e.g. explosive, toxic, hot) fluids (e.g. from the shaft seal) must be drained away so as to prevent any risk to persons or the environment. Statutory regulations are to be complied with.
- Hazards resulting from electricity are to be prevented (see for example, the VDE Specifications and the bye-laws of the local power supply utilities).
- The pumps' stability against falling over is not ensured unless it is properly mounted onto the tank.
- The female threads on the motor MUST NOT be used to lift the entire pump and motor assembly.

3.6 Safety instructions relevant for maintenance, inspection and assembly work

Any work on the machine shall only be performed when it is at a standstill, it being imperative that the procedure for shutting down the machine described in this manual be followed.

Pumps and pump units which convey hazardous media must be decontaminated.

On completion of work all safety and protective facilities must be re-installed and made operative again.

Prior to restarting the machine, the instructions listed under "Start up" are to be observed.

3.7 Signs on the pump

It is imperative that signs affixed to the machine, e.g.:

- arrow indicating the direction of rotation
- symbols indicating fluid connections be observed and kept legible.

3.8 Unauthorized alterations and production of spare parts

Any modification may be made to the machine only after consultation with the manufacturer. Using spare parts and accessories authorized by the manufacturer is in the interest of safety. Use of other parts may exempt the manufacturer from any liability.

4 Transport and storage

Protect the pump against damage when transporting.

The pumps may only be transported in a horizontal position and hooks or straps must be attached on the motor and pump end.

Do not use the pump shaft for connecting any transportation aids such as hooks or straps.

Pumps must be drained prior to their storage.

Store pump in dry and protected areas and protect it against penetration of foreign bodies.

Always store pump above the freezing point!

5 Installation and Connection

5.1 Mechanical installation

During any assembly or disassembly process the pumps must be secured against tipping through ropes for example at all times.

Pumps must be mounted securely. Piping, tank and pumps must be mounted without any tension.

The inlet is at the bottom of the immersed pump body. The distance between the inlet and the tank bottom must be so large that the inlet can not be blocked by deposits during longer shutdowns.

To obtain the full flow rate it is recommended to choose for the pipework the nominal bore diameter of the pumps cross section for connection. Therefore pipe bends should be used, not pipe angles!

The pipework must be qualified for occurring hydraulic pressure.

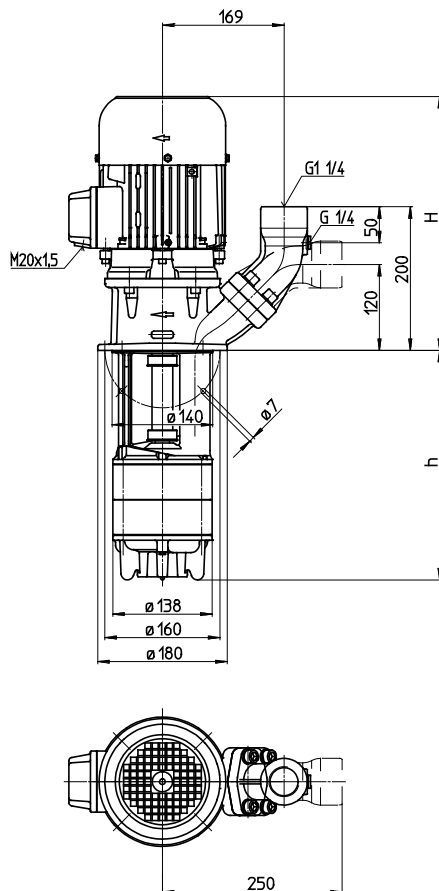

ATTENTION

Maximum tightening torque for piping connections is 150 Nm!

When installed the space around the pump must be large enough to provide sufficient cooling of the motor.

Do not prop up the pressure line via the joining socket.



The pump must be mounted in that way that rotating parts under the cover of the coolant tank can not be touched!

5.2 Electric wiring



All service work must be carried out by qualified service personnel. Pump must be disconnected from the power source and all rotating parts must stand still. Reassure that pump is disconnected from power source and cannot be switched on. Verify that there is no voltage at the terminal board!

According to the European Standard EN809 a motor overload must be installed and properly set to the full load amps stated on the pump name plate.

It is the responsibility of the machine operator to decide whether or not an additional emergency switch must be installed.



Danger!

Risk of electric shock

Our asynchronous motors can optionally be fitted with temperature sensors in the form of triplet PTC thermistors, which are used for thermal monitoring of the motor windings. Please note that the temperature sensors meet the insulation requirements of basic insulation. The improper connection of the triplet PTC thermistors to evaluation units that do not have a protective function against overvoltage in the event of a fault can lead to voltages dangerous to the touch and electric shock.

Please check whether the evaluation units you intend to use are permissible for the electrical connection of the temperature sensors.

5.2.1 Circuit



Tension voltage and frequency must correspond with the shown specification on the nameplate.

The pump must be wired so that a solid longterm electrical connection is ensured. Establish a solid ground connection.

The electrical wiring must be performed according to the wiring diagram shown inside the terminal box cover. (Please see above sample wiring diagrams)

Wiring diagram e.g.

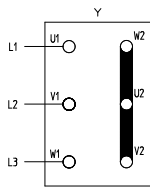

Star connection
3 x 400 V, 50 Hz
resp. 380-415 V, 50 Hz

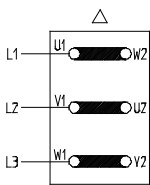

Delta connection
3 x 230 V, 50 Hz
resp. 220-240 V, 50 Hz

There may be no foreign objects such as dirt, particles or humidity inside the terminal board.

Mount terminal board cover to motor tight against dust and humidity and close up all unused wiring ports.

ATTENTION

When Variable Frequency Drives are used interfering signals might occur.

Non-sinus shaped supply voltage from a variable frequency drive might result in elevated motor temperatures.

6 Start up / Shut down

6.1 Start up

ATTENTION

Switch off at the mains.

After connection the electrical wires, close the terminal box. Briefly start the motor (max. 30 sec.) and check the rotation according to the arrow on the top of the motor.

If the direction is incorrect change over two of the power leads.

6.2 Shut down

All service work must be carried out by qualified service personnel. Pump must be disconnected from the power source and all rotating parts must stand still. Reassure that pump is disconnected from power source and cannot be switched on. Verify that there is no voltage at the terminal board! Open terminal box and disconnect the power leads. Empty out the pump.

7 Operation

Liquid level

According to the drawing shown below, the maximum liquid level must stay about 30 mm below the mounting flange, also ensure that the minimal liquid level for the STA pump is 55 mm before starting up the motor, for the SAL pump the suction hole of the pump body must be covered with liquid.

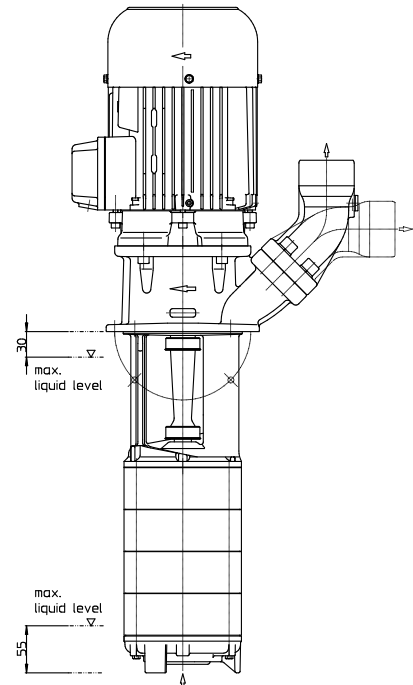

If the pump should lock up and cease, shut pump down (see 6.2) and disconnect from power supply. Pump must be uninstalled and removed from the system prior to its repair.

8 Servicing and Maintenance

ATTENTION

The surface of the motor must be kept free of dirt.

The motor shaft is spinning in permanently greased ball bearings (with special grease and increased bearing play) and does not require any special maintenance.

9 Trouble shooter's guide

Fault	Cause	Remedy
Motor does not start. no motor noise	At least two of the power supply leads have failed	Check fuses, terminals and supply leads .
	Overload has tripped	Inspect overload
Motor does not start, humming noise	One of the supply leads has failed	See above
	Impeller faulty Motor bearing faulty	Replace impeller Replace bearing
Overload trips	Pump locked up mechanically	Inspect pump hydraulics
	High on/of cycling frequency	Check application
Power consumption is too high	Wrong direction of rotation of impeller	See above
	Lime or other deposits mechanical friction	Clean pump mechanism repair pump
Motor overheats	High on/off cycling frequency	See above
	Wrong power supply (voltage or cycles)	Power supply must correspond with name plate rating
	Insufficient cooling	Check air flow at motor fan
Pump does not pump	liquid level too low	Fill up liquid
	Pump mechanism faulty	replace pump mechanism
	Pipe blocked	Clean pipe
Insufficient flow and pressure	Wrong direction of rotation of impeller	Change over two power supply leads
	Pump mechanism silted up	Clean pump mechanism
	Worn pump mechanism	Replace pump mechanism
Incorrect flow or pressure	Wrong power supply (voltage or cycles)	Power supply must correspond with name plate rating
Running noise/Vibration	Foreign objects in pump end	Remove foreign objects
	Impeller damaged	Replace impeller
	Bearing/Bushing broken	Replace bearing/bushing

10 Spare part

10.1 Spare part list for the immersion pumps of the series STA/SAL301 ... 306

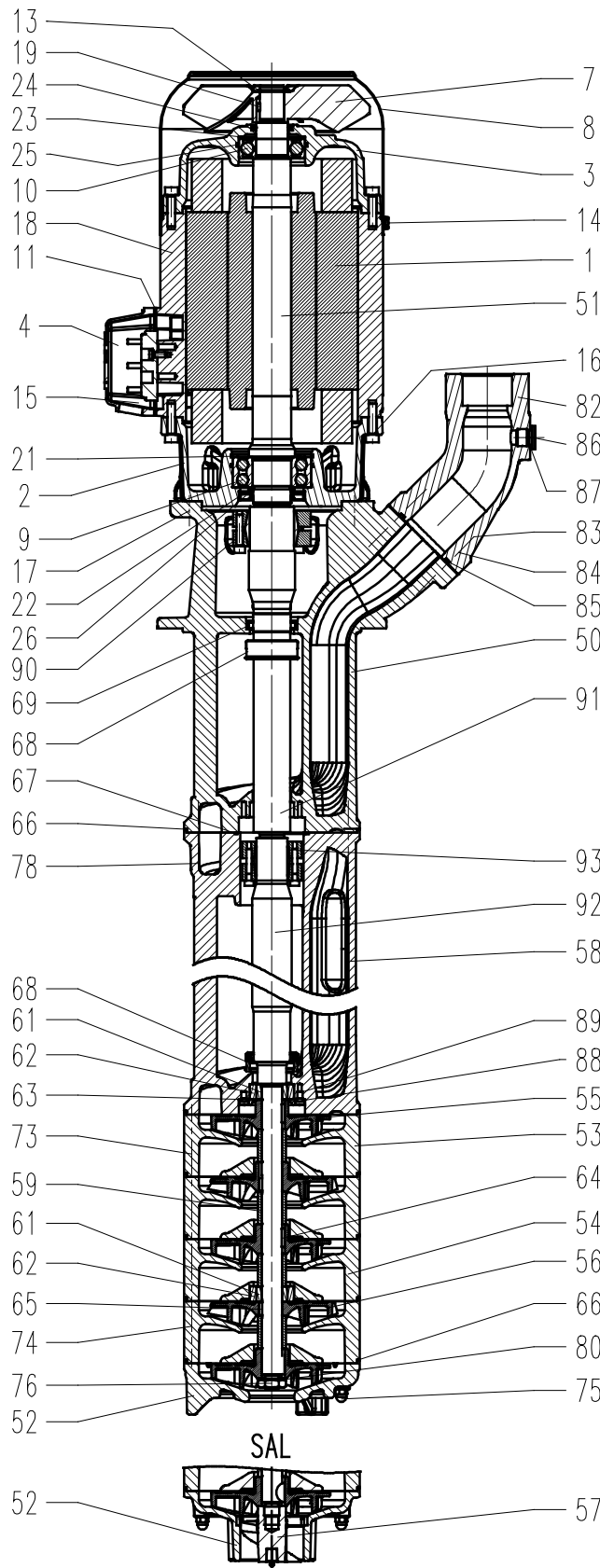

Item	Description	
1	Stator with terminal board	
2	Motor flange	
3	End shield	
4	Terminal box	
7	Fan	
8	Fan cover	
9	Ball bearing up to 1.1 kW	DIN 625
9	Ball bearing up 1.5 kW	DIN 628
10	Ball bearing	DIN 625
11	Gasket	
13	Retaining ring up to 1.1 kW	
13	Retaining ring up 1.5 kW	DIN 471
14	Thread rolling screw up 1.5 kW	DIN 7500
15	Slotted cheese head screw	DIN 84
16	Socket head cap screw up 1.5 kW	DIN 912
17	Socket head cap screw	DIN 912
18	Stud bolt with bond up to 1.1 kW	
19	Parallel pin	DIN 7
21	Retaining ring	DIN 472
22	Retaining ring	DIN 471
23	Compensation disk up 1.5 kW	
24	Shaft seal up 1.1 kW	
25	O-ring up 1.5 kW	
26	Shaft seal	
50	Pump body	
51	Shaft with rotor	
52	Inlet cover for STA	
52	Intake cover for SAL	
53	Pump plate up STA/SAL302	
54	Pump plate with bearing bush STA/SAL305...306	
55	Impeller	
56	Impeller - bearing stage STA/SAL305...306	
57	Suction screw only for SAL	
58	Extension pump body up 600 mm depth of immersion	
59	Distance liner	
61	Running sleeve	
62	Bearing bush	
63	Distance plate	
64	Woodruff key	DIN 6888
65	Woodruff key short STA/SAL305...306	
66	O-ring	
67	O-ring up 600 mm depth of immersion	
68	Splash ring	
69	Shaft seal	
73	Hexagon head screw STA/SAL301...305	DIN 931
74	Stud bolt STA/SAL306	
75	Hexagon domed cap nut STA/SAL306	DIN 1587
76	Hexagon thin nut STA	DIN 439
78	Socket head cap screw up 600 mm depth of immersion	DIN 912
80	Washer STA	
82	Joining socket	
83	Socket head cap screw	DIN 912
84	Spring washer	DIN 7980
85	O-ring	
86	Screw plug	DIN 908
87	Sealing ring	DIN 7603

88	Serrated lock washer	
89	Flat head screw	DIN 7991
90	Shaft clamp	
91	Extension shaft up 600 mm depth of immersion	
92	Insert shaft	
93	Shaft clamp up 600 mm depth of immersion	

10.2 Indications to the spare part order

Spare parts are available from the supplier. Standard commercially available parts are to be purchased in accordance with the model type. The ordering of spare parts should contain the following details:

1. Pumptype

e.g. STA304 / 590

2. Pump No.

e.g. 05242210

The date of the construction year is a component of the pumps type number.

3. Voltage. Frequency and Power

Take item 1, 2 and 3 from the nameplate

4. Spare part with item No.

e.g. Intake cover item No. 52

11 Repair Instructions / Replacing shaft clamps and shafts

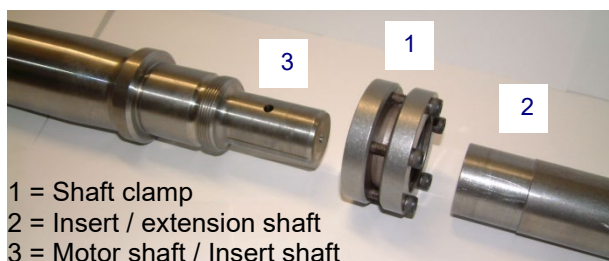

1 = Shaft clamp
2 = Insert / extension shaft
3 = Motor shaft / Insert shaft

11.1 Dismantling the insert shaft or extension shaft

- Disconnect the submersible pump from the mains both electrically and mechanically.
- Remove pump from system. Secure pump against tipping over, i.e. use ropes to secure pump.
- Set the pump down on the fan cover. Dismantle the pump unit and the extension pump body (if appropriate).



Wear safety gloves!

Risk of injury due to sharp edges on pump components, i.e. impeller blades.

- Loosen the screws on the shaft clamp (1) one after the other.



Do not, under any circumstances, remove the screws completely, **danger of injury!**

- Remove the extension shaft (2) and shaft clamp (1).
- Dismantle the pump body.
- Loosen the screws on the shaft clamp (1) (see above), pull the insert shaft (2) off the motor shaft (3).

11.2 Assembling the insert shaft and motor shaft

ATTENTION

Clean the contact surfaces of the insert shaft (2) (inside) and the motor shaft (3). They must not be lubricated or oiled.

- Set the motor down on the fan cover.
 - Position the shaft clamp (1) (use a new shaft clamp) in the centre of the cranked clamping diameter (2) of the insert shaft.
 - Insert the motor shaft (3) into the insert shaft (2).
 - **Tighten:**
Mark the first screw and tighten all the screws evenly by hand, one after the other in a clockwise direction (not cross-ways).
 - Tighten the shaft clamp (∅ 24 mm) for STA/SAL301...302
Use a torque screwdriver to tighten each screw first with 1.3 Nm then with 2.6 Nm and finally with 4 Nm (in a clockwise direction again).
 - Tighten the shaft clamp (∅ 35 mm) for STA/SAL303...306
Use a torque screwdriver to tighten each screw first with 2 Nm then with 3.5 Nm and finally with 5 Nm (in a clockwise direction again). Repeat the last turn (with 5 Nm) 3 times.
 - Mount the pump body.
 - In the case of pumps with an extension body, the assembly and tightening of the second shaft clamp (∅ 24 mm) is carried out as before.
- The remainder of the reassembly process is to be completed in the opposite order of the prior described dismantling process.

ATTENTION

Note torques for the screw connections!

When putting the pump back into use, **make sure the direction of rotation is correct!**

Tightening torques for screwed connections

Thread - ∅	M5	M6	M8	M12
Strength classes	8.8	8.8	8.8	
Tightening torque (Nm)	4.5 Nm Item. 73 Item. 75	4.5 Nm Item. 16	20 Nm Item. 17	30 Nm Item. 83 Item. 76

12 Disposal

When disposing of the pump or the packaging materials the local and national regulation for proper disposal must be complied with.

Prior to its disposal, the pump must be completely drained and decontaminated if necessary.

13 Declarations of conformity

13.1 UK declaration of conformity



UK declaration of conformity

Manufacturer

Brinkmann Pumpen, K. H. Brinkmann GmbH & Co. KG
Friedrichstraße 2
D-58791 Werdohl
Germany

This declaration of conformity is issued under the sole responsibility of Brinkmann Pumps and belongs to the following product.

Product name

Immersion pumps

Type **STA/SAL301...306**

The named product described above complies with the following statutory requirements of United Kingdom:

UK SI 2008 No. 1597 The Supply of Machinery (Safety) Regulations 2008
UK SI 2016 No. 1091 The Electromagnetic Compatibility Regulations 2016
UK SI 2020 No. 1647 The Restriction of the Use of Certain Hazardous Substances in Electrical and Electronic Equipment Regulations 2020

The following exceptions in accordance with table 1, "Table of exempted applications" are claimed: No.12 (6a), No.15 (6b), No. 18 (6c)

The following designated standards and technical specification have been applied:

EN 809:1998+A1:2009+AC:2010	EN ISO 12100:2010	EN 60204-1:2018
EN IEC 61000-3-2 :2019 +A1 :2021	EN 61000-3-3 :2013+A1 :2019 +A2 :2021 +A2 :2021/AC :2022	
EN IEC 61000-6-2 :2019	EN IEC 61000-6-3 :2021	EN IEC 63000 :2018

Additionally the following standard has been applied:

EN 60034-1 :2010/AC :2010

The instructions contained in the operating manual for installation and start up the pump have to be followed.

**Brinkmann Pumpen, K. H. Brinkmann GmbH & Co.
KG**

Werdohl, 28.05.2024

.....
Dr.-Ing. Dirk Wenderott
Chief Product Officer (CPO)
Head of Engineering

Dr. H. Abou Dayé
K. H. Brinkmann GmbH & Co. KG
Friedrichstraße 2, D-58791 Werdohl
Representative of documentation

13.2 EC declaration of conformity

DEUTSCH / ENGLISH / FRANÇAIS / ESPAÑOL



EG-Konformitätserklärung

EC declaration of conformity / Déclaration de conformité CE / Declaración de conformidad CE

Hersteller / Manufacturer / Constructeur / Fabricante

Brinkmann Pumpen, K. H. Brinkmann GmbH & Co. KG
Friedrichstraße 2, D-58791 Werdohl

Produktbezeichnung / Product name / Désignation du produit / Designación del producto

Tauchpumpen / Immersion pumps / Pompes plongeantes / Bombas de inmersión

Typ / Type / Tipo STA/SAL301...306

Das bezeichnete Produkt stimmt mit den folgenden Richtlinien des Rates zur Angleichung der Rechtsvorschriften der EG-Mitgliedsstaaten überein:

The named product conforms to the following Council Directives on approximation of laws of the EEC Member States:
Le produit sus-mentionné est conforme aux Directives du Conseil concernant le rapprochement des législations des Etats membres CEE:

El producto designado cumple con las Directivas del Consejo relativas a la aproximación de las legislaciones de los Estados Miembros de la CEE:

2006/42/EG	Richtlinie für Maschinen
2006/42/EC	Council Directive for machinery
2006/42/CE	Directive du Conseil pour les machines
2006/42/CE	Directivas del Consejo para máquinas
2014/30/EU	Richtlinie für elektromagnetische Verträglichkeit
2014/30/EU	Council Directive for Electromagnetic compatibility
2014/30/UE	Directive du Conseil pour Compatibilité électromagnétique
2014/30/UE	Directivas del Consejo para Compatibilidad electromagnética
2011/65/EU und 2015/863/EU	RoHS Richtlinien
2011/65/EU and 2015/863/EU	RoHS Directives
2011/65/UE et 2015/863/UE	Directives RoHS
2011/65/UE y 2015/863/UE	RoHS Directivas

Folgende Ausnahmen gem. Anhang III RoHS (2011/65/EU) werden in Anspruch genommen: 6a, 6b, 6c.

The following exceptions in accordance with appendix III RoHS (2011/65/ EU) are claimed: 6a, 6b, 6c

Les exceptions suivantes selon l'annexe III RoHS (2011 / 65 / UE) sont revendiquées : 6a, 6b, 6c

Las siguientes excepciones conforme al apéndice III RoHS (2011/65 / UE) son requeridas: 6a, 6b, 6c

Hinsichtlich der elektrischen Gefahren wurden gemäß Anhang I Nr. 1.5.1 der Maschinenrichtlinie 2006/42/EG die Schutzziele der Niederspannungsrichtlinie 2014/35/EU eingehalten.

With respect to potential electrical hazards as stated in appendix I No. 1.5.1 of the machine guide lines 2006/42/EC all safety protection goals are met according to the low voltage guide lines 2014/35/EU.

Conformément à l'annexe I N° 1.5.1 de la Directive "Machines" (2006/42/CE) les objectifs de sécurité relatifs au matériel électrique de la Directive "Basse Tension" 2014/35/UE ont été respectés.

Con respecto al potencial peligro eléctrico como se indica en el apéndice I No. 1.5.1 del manual de la máquina 2006/42/CE, todos los medios de protección de seguridad se encuentran según la guía de bajo voltaje 2014/35/UE.

Die Übereinstimmung mit den Vorschriften dieser Richtlinien wird nachgewiesen durch die vollständige Einhaltung folgender Normen:

Conformity with the requirements of this Directives is testified by complete adherence to the following standards:

La conformité aux prescriptions de ces Directives est démontrée par la conformité intégrale avec les normes suivantes:

La conformidad con las prescripciones de estas directivas queda justificada por haber cumplido totalmente las siguientes normas:

Harmonisierte Europ. Normen / Harmonised Europ. Standards / Normes europ. harmonisées / Normas europ. Armonizadas

EN 809 :1998+A1 :2009+AC :2010 EN ISO 12100 :2010 EN 60204-1 :2018 EN IEC 61000-3-2 :2019 +A1 :2021
EN 61000-3-3 :2013+A1 :2019 +A2 :2021 +A2 :2021/ZAC :2022 EN IEC 61000-6-2 :2019 EN IEC 61000-6-3 :2021
EN IEC 63000 :2018

Nationale Normen / National Standards / Normes nationales / Normas nacionales : **EN 60034-1 :2010/AC :2010**

Die Hinweise in der Betriebsanleitung für den Einbau und die Inbetriebnahme der Pumpe sind zu beachten.

The instructions contained in the operating manual for installation and start up the pump have to be followed.

Les indications d'installation / montage et de mise en service de la pompe prévues dans l'instruction d'emploi doivent être suivies.

Tenga en cuenta las instrucciones en el manual para la instalación y puesta en marcha de la bomba.

Brinkmann Pumpen, K. H. Brinkmann GmbH & Co. KG

Werdohl, 28.05.2024

Dr.-Ing. Dirk Wenderott
Chief Product Officer (CPO)
Head of Engineering

Dr. H. Abou Dayé
K. H. Brinkmann GmbH & Co. KG
Friedrichstraße 2, D-58791 Werdohl
Dokumentationsbevollmächtigter / Representative of
documentation/ Mandataire de documentation /
Mandatario de documentación