

Operating Instructions

BRINKMANN-Horizontal End Suction Pumps SBC820S...1120S



BRINKMANN PUMPS, Inc.

47060 Cartier Drive
Wixom, MI 48393
USA

Phone: +1 248 926 9400
Fax.: +1 248 926 9405

www.brinkmannpumps.com
sales@brinkmannpumps.com

Subject to change without prior notice.

Order - No.: BAS6808 ENGLISH

Brinkmann–Horizontal End Suction Pumps Series SBC820S...1120S

Contents

1	Indication to the manual	2	8	Servicing and Maintenance	8
2	Description of the Product	2	9	Troubleshooting Guide	9
3	Safety instructions	4	10	Spare Parts.....	10
4	Transportation and Storage.....	5	11	Repair.....	11
5	Installation and Connection	5	12	Disposal.....	12
6	Start-up / Shut-down	7	13	Terms and Conditions	13
7	Operation.....	7			

1 Indication to the manual

This operating manual gives basic instructions which are to be observed during installation, operation and maintenance of the pump. It is therefore imperative that this manual be read by the responsible personnel and operator prior to assembly and commissioning. It is always to be kept available at the installation site.

1.1 Identification of safety instructions in the operating manual

Safety instructions given in this manual non-compliance with which would affect **safety** are identified by the following symbol:



Safety sign according with ISO 3864 – B.3.1

or where **electrical safety** is involved, with:



Safety sign according with ISO 3864 – B.3.6

The signal word **WARNING** indicates a hazardous situation which, if not avoided, could result in death or serious personal injury.

The signal word **CAUTION** indicates a hazardous situation which, if not avoided, could result in minor or moderate personal injury.

The signal word **ATTENTION** indicates a **hazardous situation which, if not avoided**, may cause a risk to the machine and it's function.

2 Description of product

2.1 General description of the pump

Pumps of the series SBC are one-stage rotary pumps. The impellers are fixed on the driving shaft extension. The pump shaft and motor shaft are interconnected by means of a shaft clamp.

The cutting unit is cutting the chips and the semi-open impeller with its large clearances allows to pump the particles along with the coolant fluid from the machine back to the filter. The SBC pumps are capable of handling chip to coolant ratios of up to 1.5% by weight.

All pumps are equipped with double mechanical seal.

Pump and motor form a compact and space-saving unit.

These pumps are for horizontal installations next to or underneath a tank. The pumps are foot mounted and must be screwed down in order to ensure a secure stance.

2.2 Intended use

These pumps are not self-priming and must be gravity fed.

The pumps of the series SBC are suited for cutting aluminum chips or similar materials and for pumping these materials along with the coolant fluid.

An agitator located at the pump suction helps to break up and separate any large bundles of chips or birds' nests which reach the pump suction.

- Pay attention to the limit of application in table 1!

The cutter pumps are intended for installation in machines and cannot be operated alone.

Limit of Application (Table 1)

Type	SBC
Mediums	Coolants cooling- and cutting-oils upon request.
Flashing point of the medium to be pumped	≥ 302 °F (150 °C)
Chip material	Aluminium, steel, coloured steels max. chip to coolant ratio by weight: 1.5%
Chip geometry	Chip bundles to max. Ø 3.9 Inch (100 mm)
Kinetic viscosity of the medium	...200 SSU (...45 mm ² /s)
Temperature of medium	30 ... 175 °F (0 ... 80 °C)
Dry running	Dry running causes increased wear and should be avoided. During the test of the direction of rotation (< 30 s) permissible.
Motor cycle time per hour	The pump SBC should be operat- ed in continual operation mode, not pulsed mode.
Ambient tempe- rature	104 °F (40 °C)
Set-up altitude	3280 ft (1000 m)

**WARNING****Risk of fire and explosion!**

Pump may not be used in potentially explosive environments.

ATTENTION

The pumps are to be operated within their design limits.

Applications outside of these limits are not approved. The manufacturer is not responsible for any damages resulting from use of the pumps in such applications.

2.3 Technical data

Type	Max. del. Pressure spec. weight 1		Max. del. volume		Dimensions				Length		Weight		Power	
	PSI	bar	GPM	l/min	H Inch	mm	h Inch	mm	l Inch	mm	Lbs	kg	HP	kW
SBC820S	58	1.7	260	1000	30.7	780	20.4	518	12.9	328	187	85	6.1	4.55
SBC1120S	70	2.1	310	1150	31.9	810	20.4	518	14.1	358	196	89	8.4	6.3

Pipe connection: Suction Port DN125 / PN16

Discharge Port NPT2 (G2)

The motor is surface-cooled and compliant with DIN IEC 34 and EN 60034 (protection degree IP 55).

3 Safety instructions

When operating the pump, the safety instructions contained in this manual, the relevant national accident prevention regulations and any other service and safety instructions issued by the plant operator are to be observed.

3.1 Hazards in the event of non-compliance with the safety instructions

Non-compliance with the safety instructions may produce a risk to the personnel as well as to the environment and the machine and results in a loss of any right to claim damages.

For example, non-compliance may involve the following hazards:

- Exposure of people to electrical, mechanical and chemical hazards
- Endangering the environment due to hazardous substances being released
- Failure of important functions of the machines/plant
- Failure of specified procedures of maintenance and repair

3.2 Unauthorized modes of operation

- Pump may not be used in potentially explosive environments. **Risk of explosion!**
- Pump and discharge piping are not designed to hold any weight and may not be used as a step ladder.

3.3 Remaining Risk

Risk of Injury!

Risk of squeezing or crushing body parts when installing or removing the pump exists.

- Proper and secured lifting tools must be used.

Risk of burns!

- The pump must have cooled down sufficiently prior to commencing any repair, maintenance or installation.

3.4 Qualification and training of operating personnel

- The personnel responsible for operation, maintenance, inspection and assembly must be adequately qualified.
- Scope of responsibility and supervision of the personnel must be exactly defined by the plant operator.
- If the staff does not have the necessary knowledge, they must be trained and instructed, which may be performed by the machine manufacturer or supplier on behalf of the plant operator. Moreover, the plant operator is to make sure that the contents of the operating manual are fully understood by the personnel.

3.5 Safety instructions relevant for operation

- If hot or cold machine components involve hazards, they must be guarded against accidental contact.
- Guards for moving parts (e.g. coupling) must not be removed from the machine while in operation.
- Any leakage of hazardous (e.g. explosive, toxic, hot) fluids (e.g. from the shaft seal) must be drained away so as to prevent any risk to persons or the environment. Statutory regulations are to be complied with.
- All service work must be carried out by qualified service personnel.
- The pumps are only secured safely if properly attached to the floor or underneath a tank.
- The female threads on the motor **MUST NOT** be used to lift the entire pump and motor assembly.
- Sharp-edged components (e.g. Impellers) must only be touched with suitable work protection, e.g. with protective gloves.
- Reassure that pump is disconnected from power source and cannot be switched on.

The by the machine generated noise level depends on the type of chip material pumped.

- It is the responsibility of the machine owner to ensure that no harm from noise is caused to the machine operating personnel. i.e. PPE such as ear protection should be supplied and worn by the operator.
- Local regulations with respect to maximum allowed noise levels must be complied with at all times.

3.6 Safety instructions relevant for maintenance, inspection and assembly work

- Any work on the machine shall only be performed when it is at a standstill, it being imperative that the procedure for shutting down the machine described in this manual be followed.
- Pumps and pump units which convey hazardous media must be decontaminated.
- On completion of work all safety and protective equipment must be re-installed and made operative again.
- Prior to restarting the machine, the instructions listed under "Start up" (see point 6.1) are to be observed.

3.7 Signs on the pump

- It is imperative that signs affixed to the machine, e.g.:
 - arrow indicating the direction of rotation
 - symbols indicating fluid connections
 be observed and kept legible.

3.8 Unauthorized alterations and production of spare parts

Any modification may be made to the machine only after consultation with the manufacturer.

Using spare parts, standard parts, and accessories authorized by the manufacturer is in the interest of safety. Use of other parts will exempt the manufacturer from any liability.

4 Transport and storage



WARNING

Danger of clamping, crushing and cutting when transporting the pump!

- Protective packaging should remain on the pump end until its installation.
- The pumps may only be transported in a horizontal position and hooks or straps must be attached on the motor and pump end.

ATTENTION

- Protect the pump against damage when transporting.
- Pump may not be placed on its pump end!
- Do not use the pump shaft for connecting any transportation aids such as hooks or straps.



WARNING

Risk of injury by discharging fluid!

Pumping fluid that remains inside the pump after shut down can freeze during low temperature conditions and cause damage and cracks to pump components, such as the pump body. As a result, after restart of the pump the pumping fluid can then discharge through such cracks under high pressure and cause severe injury.

- Pumps must be drained prior to their storage.
- Store pump in dry and protected areas and protect it against penetration of foreign bodies.
- Always store pump above the freezing point!

5 Installation and Connection

5.1 Mechanical installation



WARNING

Risk of clamping or crushing body parts when installing or removing the pump exists!

- Pump must be secured with appropriate hoist.
- During any assembly or disassembly process the pumps must be secured against tipping through ropes for example at all times.
- The pumps must be securely mounted to the tank.



CAUTION

Risk of cutting and crushing!

If the pipe work is installed under tension and with stress on the pump, the discharge port can break off and the pipe work can collapse.

- Discharge piping must be installed without any tension or stress and with proper support.
- Discharge piping must never be used as a step ladder.
- The weight of the discharge piping **MUST NOT** be supported by the pump or the pump discharge!
- The pump must never under any circumstances be used as a point for securing the piping.
- No forces or torques from the piping may be allowed to affect the pump.
- Pipes must be intercepted directly before the pump and connected with no tension.
- Piping, tank and pumps must be mounted **without any tension**.

ATTENTION

- Maximum tightening torque for piping connections is 130 ft. lbs. (170 Nm)!

ATTENTION

- When installed the space around the pump must be large enough to provide sufficient cooling of the motor.

The fluid inlet is on the face side of the flange-connected pump mechanism.

The clearance between the suction opening and the tank floor should be large enough to prevent the suction opening from becoming blocked even if the coolant is heavily polluted and the pump has not been operated for long periods.

- To obtain the full flow rate it is recommended to choose for the pipework the nominal bore diameter of the pumps cross section for connection.
- Pipe bends should be used, not pipe angles.
- The pipework must be qualified for occurring hydraulic pressure.

The positions of the foot and pressure connection can be moved around the circumference to 3 different positions. On the S-type, the pipe connection can also be set to normal or parallel alignment to the pump axis.

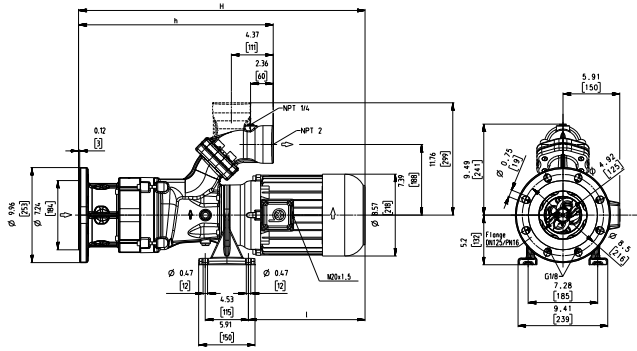

Dimensions in Inches (mm)

Drawing 1



WARNING

Risk of injury by ejected parts!

The pump may only be operated if installed within a suitable tank with proper enclosures!

- As particles and/or chips can be redirected from the pump suction at a high velocity, the tank design must incorporate appropriate protection, i.e. a tank cover, that prevents such objects from being ejected out off the tank.



WARNING

Risk of crushing and cutting by moving parts!

- The pump must be mounted in that way that rotating parts under the cover of the coolant tank can not be touched!



WARNING

Risk of fire and explosion!

The creation of an ignition spark with the presence of an ignitable aerosol can lead to risk of fire and explosion!

When pumping cooling- and cutting oils the following is to be adhered to:

- The geometry of the tank must be designed and executed in such a way that no flammable aerosol can develop (i.e. through velocity) during operation of the pump.
- The necessity of mist collection / exhaustion must be investigated and determined.
- In order to avoid the formation of an ignition spark, no foreign particles may enter the tank.
- The pump should not run dry or in slurrp mode to avoid ignition spark.

5.2 Electric wiring



WARNING

Electric shock!

All service work must be carried out by qualified service personnel. Pump must be disconnected from the power source and all rotating parts must stand still. Reassure that pump is disconnected from power source and cannot be switched on.

- Verify that there is no voltage at the terminal board!

- According to the European Standard EN809 a motor overload must be installed and properly set to the full load amps stated on the pump name plate.



WARNING

Risk of injury by uncontrolled start-up of the pump or by missing emergency shut off switch!

Unwanted pump start-up or missing shut off switches can cause severe injury through ejected parts from the pump discharge or from cutting or pulling body parts into the pump suction.

- Reassure that pump is disconnected from power source and cannot be switched on.
- It is the responsibility of the machine operator to decide whether or not an additional emergency switch must be installed.



Danger!

Risk of electric shock

Our asynchronous motors can optionally be fitted with temperature sensors in the form of triplet PTC thermistors, which are used for thermal monitoring of the motor windings. Please note that the temperature sensors meet the insulation requirements of basic insulation. The improper connection of the triplet PTC thermistors to evaluation units that do not have a protective function against overvoltage in the event of a fault can lead to voltages dangerous to the touch and electric shock.

Please check whether the evaluation units you intend to use are permissible for the electrical connection of the temperature sensors.

5.2.1 Circuit



WARNING

Electric shock!

Supply voltage and frequency must correspond with the shown specification on the nameplate.

- The pump must be wired so that a solid long-term electrical connection is ensured.
- Establish a solid ground connection.

The electrical wiring must be performed according to the wiring diagram shown inside the terminal box cover.

(Please see above sample wiring diagrams):

Wiring diagram e.g.

Voltage changing 1:2 YY / Y
e.g. 230 / 460 V, 60 Hz

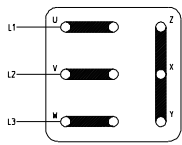

YY
Low Voltage

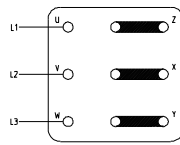

Y
High Voltage

Circuit on request

Y (Star connection)
up to 7.4 HP
(5.5 kW)

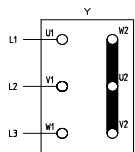

Y 440 V – 480 V
60 Hz

Δ (Delta connection)
8, 8.7, 10.1, 12.1, 14.7, 17.4 HP
(6, 6.5, 7.5, 9, 11, 13 kW)

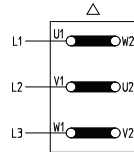

Δ 440 V – 480 V
60 Hz

Voltage changing Δ / Y.

e. g. 220 V – 240 V / 380 V – 420 V, 50 Hz

Δ (Delta Connection)

Y (Star Connection)

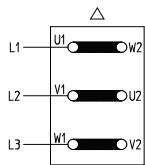

Δ 220 V – 240 V,
50 Hz

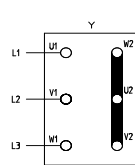

Y 380 V – 420 V,
50 Hz

There may be no foreign objects such as dirt, particles or humidity inside the terminal board.

- Mount terminal board cover to motor tight against dust and humidity and close up all unused wiring ports.

ATTENTION

When Variable Frequency Drives are used interfering signals might occur. Non-sinus shaped supply voltage from a variable frequency drive might result in elevated motor temperatures.

6 Start up / Shut down

6.1 Start up

ATTENTION

- After connection the electrical wires, close the terminal box. Briefly start the motor (max. 30 sec.).
- Check the rotation according to the arrow on the top of the motor.

If the direction is incorrect change over two of the power leads.

6.2 Shut down



WARNING

Electric shock!

All service work must be carried out by qualified service personnel. Pump must be disconnected from the power source and all rotating parts must stand still. Reassure that pump is disconnected from power source and cannot be switched on.

- Verify that there is no voltage at the terminal board!
- Open terminal box and disconnect the power leads.
- Empty out the pump.

7 Operation



WARNING

Risk of injury by uncontrolled start-up of the pump or absence of emergency shut off switch!

- Unwanted pump start-up or missing shut off switches can cause severe injury through ejected parts from the pump discharge or from cutting or pulling body parts into the pump suction.
- Reassure that pump is disconnected from the power source and cannot be switched on.
- It is the responsibility of the machine operator to decide whether or not an additional emergency switch must be installed.

Liquid level

These pumps are not self-priming and must be gravity fed.

Possible leakage must be drained away so as to prevent any risk to persons or the environment.

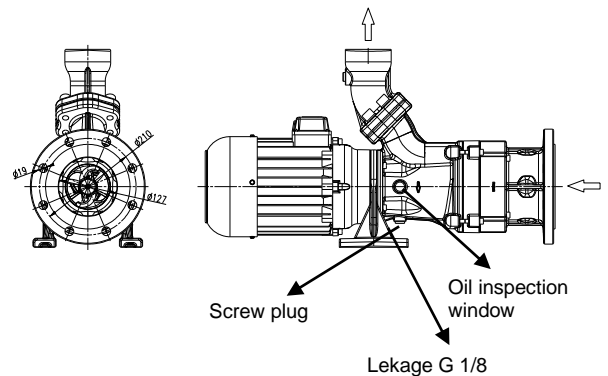

Drawing 2

**WARNING****Risk of fire and explosion!**

The creation of an ignition spark with the presence of an ignitable Aerosol can lead to risk of fire and explosion.

The fluid level must be above the suction mouth of the pump during pumping of cooling- and cutting oils in order to avoid the possibility of the creation of an ignition spark.

- Unwanted objects, such as broken tools or indexing plates which still lie under the pump after stopping the working process must be taken out in regular intervals!
- Any repair or maintenance work must be performed after the pump has been turned off and the shaft has come to a complete stop.
Risk of injury!
See provided warning label!
- If the pump should lock up and cease, shut pump down (see point 6.2) and disconnect from power supply. Pump must be uninstalled and removed from the system prior to its repair.

ATTENTION

Pulsed mode causes increased wear due to the return flow of chips and additional load on the bearings.

- The SBC pump should be operated in continual operation mode, **not pulsed mode!**
- The pump should transport medium without chips for 1-2 minutes before being switched off!

8 Servicing and Maintenance**CAUTION****Risk of burns!**

- The pump must have cooled down sufficiently prior to commencing any repair, maintenance or installation.

**WARNING****Risk of injury through contaminated parts!**

- Pumps and pump units which convey hazardous media must be decontaminated.

ATTENTION

- The surface of the motor must be kept free of dirt.

The motor shaft is spinning in permanently greased ball bearings and does not require any special maintenance.

- On completion of work all safety and protective equipment must be re-installed and made operative again.

- Prior to restarting the machine, the instructions listed under “Start up” (point 6.1) are to be observed

8.1 Pumps with double mechanical seal (-GD)**ATTENTION**

Pumps with double mechanical seal (-GD) are identified by the letters GLRD stamped in on the motor side of the pump foot and must include an oil receiver with a capacity of 0.45 litres. Check this through the inspection window.

Oil receiver Castrol WHITEMOR WOM14 or equivalent oil.

9 Troubleshooting Guide

fault	Cause	Remedy
Motor does not start, no motor noise	At least two of the power supply leads have failed	Check fuses, terminals and supply leads .
	Overload has tripped	Inspect overload
Motor does not start, humming noise	One of the supply leads has failed	See above
	Impeller faulty Motor bearing faulty	Replace impeller Replace bearing
Overload trips	Pump locked up mechanically	Inspect pump hydraulics
	High on/of cycling frequency	Check application
Power consumption is too high	Wrong direction of rotation of impeller	See above
	Lime or other deposits	Clean pump mechanism
	Mechanical friction	Repair pump
Motor overheats	High on/off cycling frequency	See above
	Wrong power supply (voltage or cycles)	Power supply must correspond with name plate rating
	Insufficient cooling	Check air flow at motor fan
Pump does not pump	liquid level too low	Fill up liquid
	Pump mechanism faulty	replace pump mechanism
	Pipe blocked	Clean pipe
The pump pumps no chips	Chip breaker worn or damage	Replace the chip breaker
Insufficient flow and pressure	Wrong direction of rotation of impeller	Change over two power supply leads
	Pump mechanism silted up	Clean pump mechanism
	Worn pump mechanism	Replace pump mechanism
Incorrect flow or pressure	Wrong power supply (voltage or cycles)	Power supply must correspond with name plate rating
Running noise/Vibration	Foreign objects in pump end	Remove foreign objects
	Impeller damaged	Replace impeller
	Bearing/Bushing broken	Replace bearing/bushing

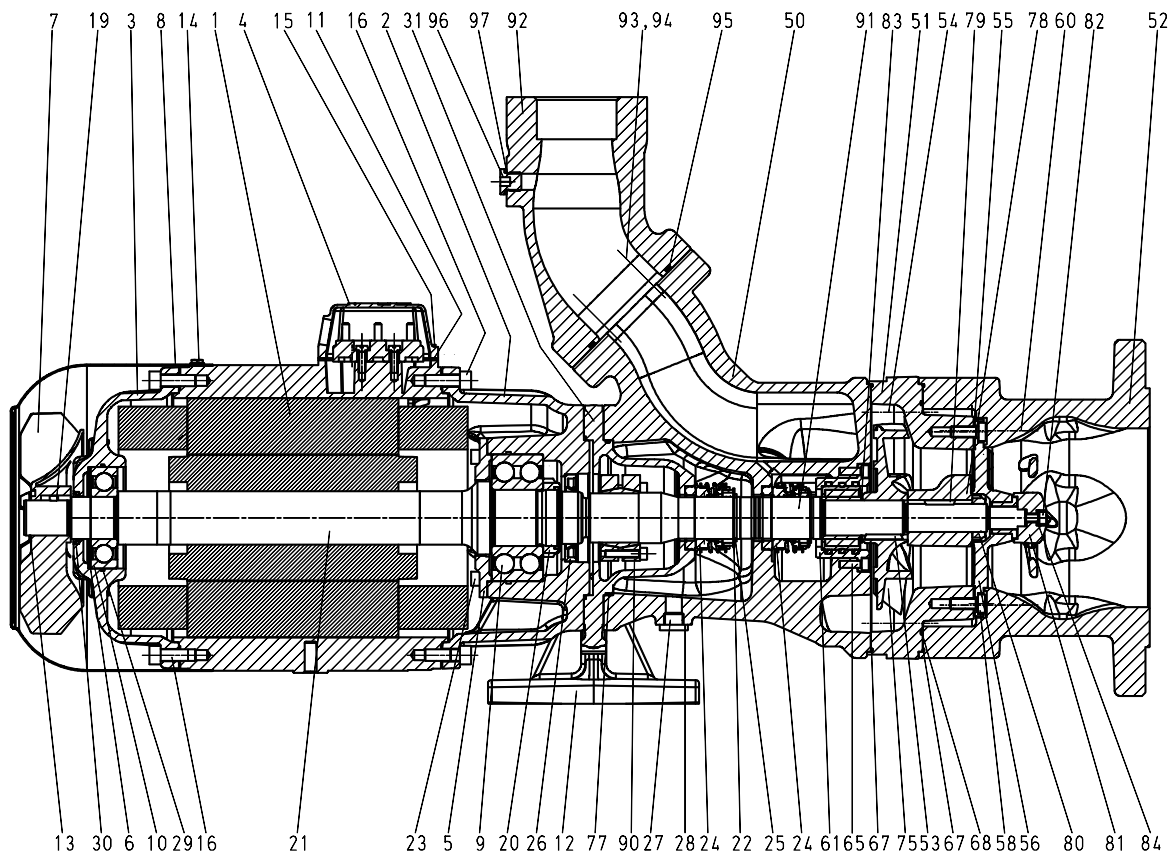
10 Spare part**10.1 Spare part list for the Brinkmann pumps
Series SBC820S...1120S****Drawing 4****Item Description**

1	Stator with terminal board	
2	Motor flange	
3	End shield	
4	Terminal box	
5	Bearing cover	
6	Compensation disk	
7	Fan	
8	Fan cover	
9	Ball bearing	DIN 628
10	Ball bearing	DIN 625
11	Gasket	
12	Pump foot	
13	Retaining ring	
14	Spiral-shaped screw	DIN 7500
15	Socket head cap screw	DIN 84
16	Socket head cap screw with lock	DIN 912
19	Parallel pin	DIN 7
20	Shaft nut	
21	Motor shaft with rotor	
22	Shim ring	
23	Socket head cap screw	DIN 912
24	Mechanical seal	
25	Circlip	
26	Shaft seal	
27	Oil inspection window	
27	Screw plug	DIN 908
28	Sealing ring	DIN 7603
29	O-ring	
30	Shaft seal	
31	Socket head cap screw with lock	DIN 912

Item Description

50	Pump body	
51	Intake cover	
52	Connection cover	
53	Woodruff key	DIN 6888
54	Socket head cap screw with lock	DIN 912
55	Shim ring	
56	Chip breaker with bearing bush	
58	Socket head cap screw with lock	DIN 912
60	Socket head cap screw with lock	DIN 912
61	Bushing cartridge assembly	
65	Socket head cap screw	DIN 912
67	O-ring	
68	O-ring	
75	Impeller	
77	O-ring	
78	Suction screw	
79	Woodruff key	DIN 6888
80	Shaft nut	
81	Agitator	
82	Socket head cap screw with lock	DIN 912
83	Shim ring	
84	Serrated lock washer	
90	Shaft clamp	
91	Insert shaft	
92	Joining socket	
93	Socket head cap screw	DIN 912
94	Spring washer	DIN 7980
95	O-ring	
96	Screw plug	DIN 908
97	Sealing ring	DIN 7603

10.2 Indications to the spare part order

Spare parts are available from the supplier. Standard commercially available parts are to be purchased in accordance with the model type. The ordering of spare parts should contain the following details:

1. **Pumptype**
e.g. SBC1120S
2. **Pump Serial No.**
e.g. 09246808
The date of the construction year is a component of the pumps type number.
3. **Voltage, Frequency and Power**
Take item 1, 2 and 3 from the nameplate
4. **Spare part with item No.**
e.g. Intake cover item No. 53

11 Repair Instructions / Replacing the rotary mechanical seal / the shaft clamp

11.1 Replacing the rotary mechanical seal



WARNING

Risk of injury due to sharp edges on pump components, i.e. impeller blades!

- Wear safety gloves!
- Disconnect the pump electrically and mechanically.
 - Note the markings on the pump components prior to dismantling.
 - When completely dismantling a unit with dual axial face seals, drain the medium in the blocking chamber through the screw plug (27).
- Loosen the socket head cap screws (60) and remove the connection cover (52).
- Loosen the Socket head cap screws (82) and remove the agitator (81) with serrated lock washer (84).
- Loosen the socket head cap screws (58) and remove the shim ring (55) and the chip breaker (56).
- Loosen the shaft nut (80) and remove the suction screw (78).
- Loosen the socket head cap screws (54) and remove the intake cover with o-ring (67).
- Use two screwdrivers to push the impeller (75) from the insert shaft (91). Insert the screwdrivers between the impeller (75) and the pump body (50).
- Remove the woodruff key (53) from the insert shaft (91). Loosen the socket head cap screws (65) and remove the bushing cartridge assembly (61) with the shim ring (83).
- Remove the circlip (25) and the shim ring (22).
- Remove the rotating axial face seal unit (24b-24e).
- Loosen the Socket head cap screws (31) and remove the pump body (50).

- Remove circlip (25) and shim ring (22) and remove the rotating axial face seal unit (24b-24e).
 - To replace the insert shaft, see position 11.2).
 - When changing an axial face seal, remove the stationary axial face seal unit (24a) from the pump body (50) and pump foot (12). Clean the seat of the seal and the pump parts!
- The mechanical seal (24) should now be completely replaced. If necessary replace the o-rings (67), (77) and impeller (75).
- Fit a new mechanical seal.
- The sliding surfaces of the axial face seal must be free of dirt and grease. Lightly moisten the collar (24a) with prill water and press the stationary axial face seal unit (24a) into the pump body (50) and pump foot (12).
 - Slide the rotating axial face seal unit (24b-24e) onto insert shaft (91) and fix in position using shim ring (22) and circlip (25).
- The remainder of the reassembly process is to be completed in the opposite order of the prior described dismantling process.

ATTENTION

Assembly help and detailed instruction is demanded for the assembly of the pump and adjusting of the cutting unit!

- Request the required documents from the manufacturer.

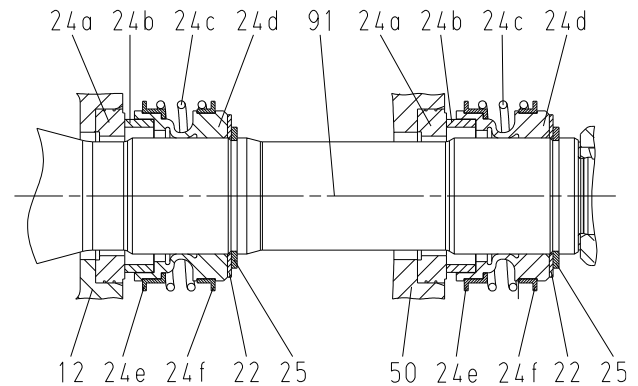

Drawing 4

11.2 Dismantling the insert shaft

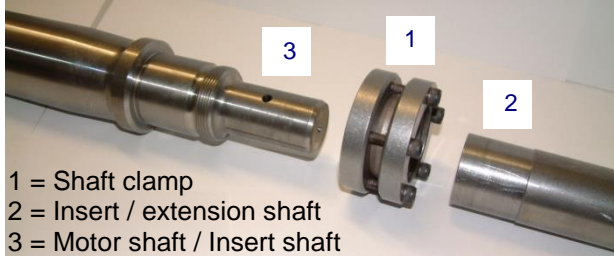

1 = Shaft clamp
2 = Insert / extension shaft
3 = Motor shaft / Insert shaft

Drawing 5

- Disconnect the inline pump from the mains both electrically and mechanically.



CAUTION

Risk of burns!

- The pump must have cooled down sufficiently prior to commencing any repair or maintenance.



WARNING

Risk of squeezing or crushing body parts when installing or removing the pump exists!

- Secure pump with appropriate hoist.
- Remove pump from system. Secure pump against tipping over, i.e. use ropes to secure pump.
- Empty out the Pump and dismantle the pump unit.



WARNING

Risk of injury due to sharp edges on pump components, i.e. impeller blades!

- Wear safety gloves!
- Dismantle the pump body and the pump foot.



WARNING

Risk of injury by discharging parts!

- Do not, under any circumstances, remove the screws on the shaft clamp (1) completely.
- Loosen the screws on the shaft clamp (1).
- Remove the insert shaft (2) and shaft clamp (1) off the motor shaft (3).

11.3 Assembling the insert shaft and motor shaft



WARNING

Risk of jamming or crushing during pump installation or removal!

- Secure pump with appropriate hoist.

ATTENTION

- Clean the contact surfaces of the insert shaft (2) (inside) and the motor shaft (3). They must not be lubricated or oiled.
- Disassemble the fan cover and the fan from the motor. Set the pump down on the end of the shaft (a fixture must be used).
- Position the shaft clamp (1) (use a new shaft clamp) in the centre of the cranked clamping diameter (2) of the insert shaft.
- Insert the motor shaft (3) into the insert shaft (2).
- Tighten:
Mark the first screw and tighten all the screws evenly by hand, one after the other in a clockwise direction (not cross-ways).
- Use a torque screwdriver to tighten each screw first with 1.5 ft. lbs. (2 Nm) then with 2.6 ft. lbs. (3.5 Nm) and finally with 3.7 ft. lbs. (5 Nm) (in a clockwise direction again).
- Repeat the last turn with 3.7 ft. lbs. (5 Nm) 3 times.



WARNING

Risk of injury due to sharp edges on pump components, i.e. impeller blades!

- Wear safety gloves!
- Mount the pump foot and the pump body.
- The remainder of the reassembly process is to be completed in the opposite order of the prior described dismantling process.

ATTENTION

Assembly help and detailed instruction is demanded for the assembly of the pump and adjusting of the cutting unit!

- Request the required documents from the manufacturer.
- Note torques for the screw connections!
-

Tightening torques for screwed connections

Thread - Ø	M5	M6		M8	M16
Strength classes	8.8	8.8	12.9	8.8	8.8
Tightening torque ft.lbs. (Nm)	2.2 (3)	3.3 (4.5)	12 (16) Item.82	15 (20)	44 (60) Item.93

- Position the pump laterally and fill the pump blocking chamber (-GD) with oil until it reaches the oil inspection window (27) (0.45 litres).
- Fit the sealing ring (28) and screw on the screw plug (27).
- Pump Installation. Secure pump against falling over. i.e. with use of safety straps.
- Reconnect immersion pump as described in point 5.

ATTENTION

- When putting the pump back into use, **make sure the direction of rotation is correct** (see point 6.1)!

12 Disposal

When disposing of the pump or the packaging materials the local and national regulation for proper disposal must be complied with.

- Prior to its disposal, the pump must be completely drained and decontaminated if necessary.

13 Brinkmann Pumps Inc. Terms and Conditions

The following terms and conditions govern all quotations made by Brinkmann Pumps Inc. („Brinkmann“) and any orders based upon these quotations. No contract term or condition shall be amended, deleted or added without the express written consent of Brinkmann, and Brinkmann hereby rejects any terms set forth in any other writing which are in addition to or different from the terms in this quotation.

These items and conditions and any other terms and conditions delivered in writing by an authorized agent of Brinkmann contemporaneously herewith constitute the complete agreement between Brinkmann and the buyer and supersede all prior oral, written or printed statements of any kind (including any terms and conditions submitted by the buyer and performance or production data from any source whatsoever, including references to accuracy, capacity, and capability of products, all of which are estimates only) made by Brinkmann or the buyer or their respective representatives. No statement, recommendation or assistance given by Brinkmann or its representatives to buyer or its representatives, in connection with the use of any products by buyer, shall constitute a waiver by Brinkmann of any of the provisions hereof or affect Brinkmann's liability, as defined herein. All transactions covered hereby and all terms and conditions of sale shall be governed by the laws of the state of Michigan.

Prices

The products offered in this proposal and the prices quoted are based on our understanding of buyer's requirements; any change in requirements will necessitate a revision in prices quoted. Prices are F.O.B. our dock, Wixom, Michigan, or other location as specified on proposal. Brinkmann's prices do not include sales, use, excise, or similar tax, applicable to the sale or use of the equipment proposed. These taxes shall be paid by the buyer, or in lieu thereof, the buyer shall provide Brinkmann with a tax exemption certificate acceptable to the taxing authorities.

Delays or failure to deliver

Brinkmann shall not be responsible for delay or failure to deliver due to acts of God, or to government action (civil or military), or to prior orders, or to fire, embargo, strike or other labor problems, wrecks, delays in transportation, unusually severe weather or inability to obtain necessary labor or materials from the usual source of supply, or any other circumstances beyond Brinkmann's control.

Brinkmann shall have the right to furnish suitable substitutes for materials which cannot be obtained because of such force majeure.

Installation

Buyer shall install at its own expense, all products covered hereby in accordance with the operating instructions to be furnished to buyer upon request. Unless otherwise stated, no installation services are included in the price indicated.

Limited warranty

Brinkmann warrants to the buyer (but not to any others) for a period of one year from date of shipment that all new parts are free from defects in material and workmanship.

Brinkmann's said warranty shall exist only if buyer gives written notice to Brinkmann within ten days after the first determination that the part is defective and within the aforesaid one year period from the date of shipment and includes in said notice consent to Brinkmann to inspect, at any reasonable time, said part and the machine in which it may be embodied, and if, and only if, Brinkmann determines to its reasonable satisfaction upon said inspection that said part and the machine in which it may be embodied are, and have been, used in accordance with all Brinkmann's instructions as to maintenance and operation set forth in the operating instructions relating to the machine. Brinkmann's warranty is limited to shipping to buyer replacement of any part which is so proven to be defective and in any event shall have **no liability whatsoever for incidental or consequential damage or loss of profit**, including damages resulting from personal injury or death, or damage to, or loss of use of, any property. Brinkmann is not responsible for shipping costs or labor, extends no warranty of any kind for gasket, seals and wear and tear materials. Notwithstanding any provisions of these terms and conditions, **this warranty is the only warranty extended by Brinkmann in connection with any sales of products and is in lieu of all other warranties, express or implied, including warranties of merchantability or fitness for purpose.** No agent, employee or representative of Brinkmann has any authority to bind Brinkmann to any affirmation, representation, or warranty concerning the products that are the subject of this quotation beyond that specifically included in the written quotation. Brinkmann shall have no obligation to install or provide improvements or changes in design adapted by Brinkmann for similar equipment subsequent to acceptance of buyer's order.

Warranties have been discussed and understood by both parties.

Buyer's use and O.S.H.A.

Buyer shall use and require all persons operating the equipment to use all proper and safe operating procedures set forth in operating instructions relating to the equipment and observe all occupational safety health and standards act (O.S.H.A.), American National Standard Institute (ANSI), and state regulations as required and all available, feasible and practical point of operation safety devices consistent with buyer's use of the equipment. Buyer shall not remove or modify, any device, warning sign, operating instructions or work handling tools installed on or attached to the equipment. Buyer shall notify Brinkmann promptly, in writing, and in all events within ten (10) days after its occurrence, of any accident or malfunction involving any equipment which results in injury to or death of persons or damage to property, or the loss of use thereof and buyer shall cooperate fully with Brinkmann in investigation and determining the cause of any such occurrence of malfunction. At Brinkmann's request made at any time, buyer will either at its or Brinkmann's place of business, permit to redesign, remodel or revise the equipment and buyer waives any claims against Brinkmann for buyer's inability to use the equipment during the time that same is out of service for such revision, modification or redesign.

Brinkmann shall not be responsible for any failure to comply which results from the location, operation, design, use or maintenance of the equipment from alternation of the equipment by persons or firms other than Brinkmann, or from an option or accessory to the equipment by persons or firms other than Brinkmann, which was available to the buyer but omitted at the buyer's direction, or from design or instructions furnished by the buyer or its agents. In view of the above, Brinkmann does not make any warranties with respect to O.S.H.A. requirements, including noise; and will not be responsible for fines, penalties, or consequential damages.

Payment terms

Net payment in full of all invoices is due thirty (30) days net, unless stated otherwise in quotation. Any unpaid balance thereafter shall be subject to a service charge of 1.75 % per month or, if illegal, at the highest rate allowed by law. There shall be no extension or change in the time for payment due to delay in installation and/or delays in operation of the equipment caused by damage,

warranty service or warranty replacement of parts. If after Brinkmann's acceptance of buyer's purchase order, buyer requests Brinkmann to delay shipment of the equipment, the purchase price shall become due and owing thirty (30) days after the equipment is ready for shipment.

If buyer fails to pay the purchase price as provided herein and Brinkmann institutes a lawsuit for the collection of said price, buyer agrees to pay Brinkmann's reasonable attorney fees incurred in connection therewith.

Acceptance of orders

Quotations are offered for written acceptance within thirty (30) days from date (unless otherwise stated) but are subject to change without notice at any time before acceptance. If any order contains printed, stamped or other provisions inconsistent or in conflict with the terms and conditions hereof, the terms and conditions hereof shall control, unless otherwise specifically stated by Brinkmann in writing. All clerical errors are subject to correction in favor of either party upon notice of either party. All orders are subject to the credit approval of Brinkmann. An order containing subject matter not within the contemplation of the proposal shall be subject to a further quotation as to price or delivery or both. Modifications, changes, deferred shipments, cancellations or additions will be effective only if accepted by Brinkmann in writing and then only upon terms that will indemnify Brinkmann against all costs and losses.

Title and security agreement

Delivery to carrier shall constitute transfer to the buyer, and all risk of loss or damage in transit shall be borne by the buyer.

By execution of a purchase order, buyer hereby grants to Brinkmann a security interest in the equipment covered by the proposal, and its products and/or proceeds in order to secure the payment of the purchase price thereof and buyer authorizes to file financing statements reflecting this security interest without buyer's signature. Buyer will cooperate with Brinkmann in preparing documents necessary to perfect this security interest.

Proprietary and other materials

This quotation and all drawings, specifications, materials, patterns, and special purpose manufacturing aids which are supplied to buyer by Brinkmann shall be kept in confidence and shall be listed and maintained in suitable condition at the expense of buyer and are to be considered the property of Brinkmann held on consignment by buyer and to be insured while in buyer's possession. Such

articles and all copies thereof from any source shall be returned to Brinkmann at any time upon request and shall not be used for or by any third parties without the express written permission of Brinkmann.

Performance in event of default

In addition to the rights and remedies conferred upon Brinkmann by law, Brinkmann will not be required to proceed with the performance of any order or contract if buyer is in default in the performance of any order or contract with Brinkmann and in case of doubt as to buyer's financial condition, shipments under an order may be suspended or sent sight draft with bill of lading attached and Brinkmann may decline further shipments except for cash before shipment.

Hold harmless/indemnity

Except to the extent of the limited warranty set forth above and Brinkmann's own gross negligence or willful misconduct, buyer hereby: (1) waives, releases and discharges any and all claims of any and every kind (including but not limited to injury or death of any person or damage to property), which it may have at any time against Brinkmann, its agents or employees, by reason of or arising out of any claimed improper design, specification or manufacture of the equipment sold hereunder, or of any claimed inadequate or insufficient safeguards or safety devices; and (2) covenants to indemnify and hold harmless Brinkmann, its agents and employees of, from and against any and all loss, damage, expense (including attorney's fees), claims, suits or liability which Brinkmann or any of its employees may sustain or incur at any time for or by reason of any injury or death of any person or persons or damage to any property, arising out of any claimed improper design or manufacture of the equipment sold hereunder, or of any claimed inadequate or insufficient safeguards or safety devices.

Electrical equipment

Motors, electrical equipment and wiring on the equipment quoted will be supplied in accordance with the manufacturer's standards. Unless specifically quoted they are not guaranteed to meet ordinances of any local governing body and the responsibility of conforming to any local ordinance is assumed by the buyer.

Inspection and testing, production estimates and performance

All working drawings or other materials provided by Brinkmann are for general information purposes only and may or may not relate to buyer's order or other equipment. Any specifications contained therein are not binding on Brinkmann except as expressly so stated. Brink-

mann reserves the right to make, at any time, such changes in detail of design or construction as shall in the sole judgment of Brinkmann constitute an improvement over former practice. Production data, where given, are based on Brinkmann's careful analysis and understanding of the limits of accuracy, machinability of materials, amount of material to be removed, handling facilities provided, and location points but are nonetheless an estimate only and not guaranteed or warranted. In no event shall Brinkmann be responsible for performance figures supplied by other parties. If by written agreement the equipment is to be subject to acceptance tests before shipment, rejection under this clause must take place prior to shipment.

Returned equipment

In no case is equipment to be returned without first obtaining written permission from Brinkmann. Unless otherwise expressly agreed an order for equivalent value must accompany returned equipment and all such returned equipment will be accepted for credit only after inspection. Equipment returned without good cause and for which no credit is given shall be subject to a restocking charge. Buyer returning equipment must pay transportation charges and bear risks of loss or damage to goods while in transit. Acceptance of returned products by Brinkmann's receiving department shall not bind Brinkmann nor have any force or effect unless acceptance is made by Brinkmann in writing.