

快吸式沉水泵 SAL601...608

轴向/半开式叶轮

SAL601...608

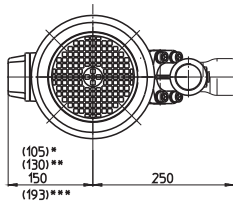
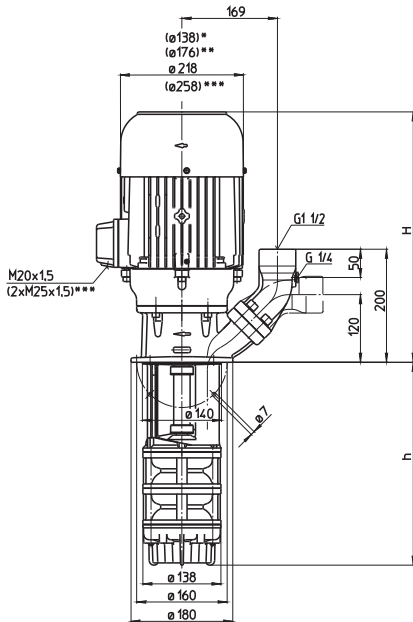

*) SAL601 尺寸
**) SAL602 尺寸
***) SAL607, 608 尺寸

型号	流量 在某个 扬程下 l/min / m	高度 H mm	沉水 深度 h mm	重量 kg	功率 kW	电压 V 3 ~	频率 Hz	电流 A	转速 1/min
SAL601/150	400/3	361	150	23.5	1.1	220-240	50	4.33	2850
230			230	24.5		380-415	50	2.50	2850
300			300	25.5					
380			380	27.0	1.27	460	60	2.4	3440
470			470	28.0					
580			580	30.0					
780			780	36.0					
930			930	38.0					
SAL602/220	400/10	439	215	40	2.2	220-240	50	7.8	2890
300			295	41		380-415	50	4.5	2890
370			365	42					
450			445	43	2.55	460	60	4.4	3480
540			535	45					
650			645	47					
850			845	54					
1000			995	55					
SAL603/280	400/16	478	280	54	3.3	220-240	50	11.6	2930
360			360	55		380-415	50	6.7	2930
430			430	56					
510			510	57	3.8	460	60	6.4	3520
600			600	59					
710			710	61					
910			910	67					
1060			1060	69					
SAL604/350	400/23	508	345	63	5.0	220-240	50	17.3	2920
430			425	64		380-415	50	10.0	2920
500			495	65					
580			575	67	5.75	460	60	9.5	3520
670			665	68					
780			775	69					
980			975	76					
1130			1125	78					
SAL605/410	400/32	508	410	66	5.5	220-240	50	18.9	2915
490			490	67		380-415	50	10.9	2915
560			560	68					
640			640	69	6.3	460	60	10.4	3510
730			730	71					
840			840	73					
1040			1040	79					
SAL607/540	400/44	587	540	103	7.5	380-415	50	14.3	2950
620			620	104					
690			690	105	8.6	460	60	13.7	3550
770			770	106					
860			860	108					
970			970	109					
SAL608/600	400/57	587	600	113	9.0	380-415	50	16.7	2955
680			680	114					
750			750	115	10.3	460	60	15.8	3550
830			830	116					
920			920	117					
1030			1030	120					

快吸式沉水泵

配备了专利的"BRINKMANN 气液分离系统" 特别适用于抽送极度膨胀液体(乳化液, 冷却/切削油), 针对车削, 铣削或磨削的应用。

一旦液面达到吸入端时, 快吸式沉水泵能快速进入稳定的工作状态。

SAL 系列提供了一个(SAE)法兰 用于连接压力表。

该法兰可用于水平及垂直管路连接。

应用

流体类型

冷却液

冷却/切削油

流动黏度

...45 mm²/s (45 cSt)

工作温度

0...80° C

结构

泵体

端盖

轴向叶轮

径向叶轮

轴

铸铁

铸铁

铸钢

黄铜

钢

可选:

径向叶轮

铸钢

