

Immersion Pumps (S)TC63

Closed impellers

STC63/270...750

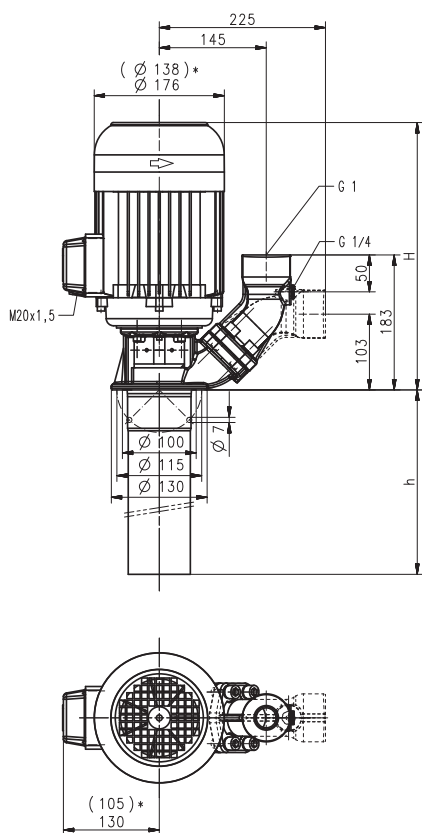

TC63/270...750

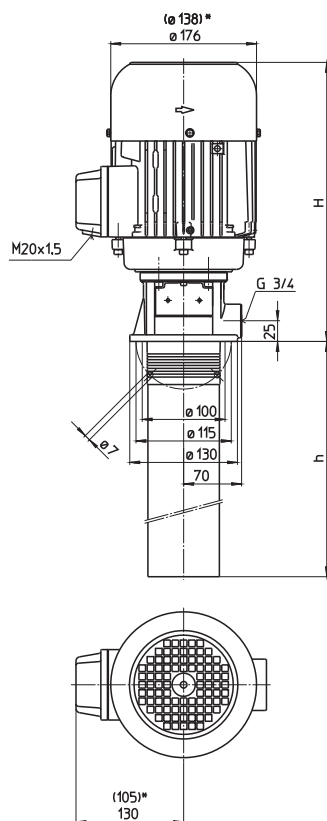

*) Dimensions for (S)TC63/270...350

Type	Vol. del. at manom. del. head l/min / m	Height H mm	Depth of im- mersion h mm	Weight kg	Power kW	Voltage 3~ V	Fre- quen- cy Hz	Current A	Speed 1/min
(S)TC63/270	60/22	318	275	13.5	0.75	220-240 380-415	50 50	3.24 1.87	2850 2850
(S)TC63/350	60/30	318	340	15	0.86	460	60	1.85	3440
(S)TC63/440	60/40	367	440	22	0.92	220-240 380-415	50 50	3.8 2.2	2840 2840
(S)TC63/560	60/55	425	565	28	1.06	460	60	2.1	3440
(S)TC63/745	60/77	425	755	30	1.3	220-240 380-415	50 50	4.85 2.80	2900 2900
(S)TC63/750	60/90	425	755	31	1.49	460	60	2.7	3500
(S)TC63/750	60/90	425	755	31	1.9	220-240 380-415	50 50	6.84 3.95	2900 2900
(S)TC63/750	60/90	425	755	31	2.18	460	60	3.9	3500
(S)TC63/750	60/90	425	755	31	2.2	220-240 380-415	50 50	7.8 4.5	2890 2890
(S)TC63/750	60/90	425	755	31	2.55	460	60	4.4	3480
(S)TC63/750	60/90	425	755	31	2.6	220-240 380-415	50 50	9.30 5.35	2880 2880
(S)TC63/750	60/90	425	755	31	2.94	460	60	5.1	3480

Immersion Pumps

Our multistage pump models (S)TC25... (S)TC460 have been especially developed to supply **internally cooled tools** with coolant fluid.

Closed impellers provide optimal hydraulic efficiencies while minimizing power consumption.

A **frequency converter** can be supplied for **special applications** or for matching the pump characteristic to a specific duty point.

See page "Control/Regulation" in the Technical Information section of this catalog for further information.

Extended length is possible. See medium pressure pumps features within the technical information section.

Applications

- Types of fluid
 - Industry water
 - coolants
 - cooling/cutting oils
- Kinematic viscosity
 - ...45 mm²/s (45 cSt)
- Pumping temperature
 - 0...60° C

Construction

Pump body	cast iron
Pump shell	steel
Cover	PBTP
Intake strainer	steel
Impellers	PBTP
Shaft	steel
Mechanical seal	SiC
O-rings	Viton
Optional:	
Pump body	CrNi-steel
Threaded inlet	G 1 ¼

Noise level

(S)TC63/270...(S)TC63/350	58 dBA
(S)TC63/440...(S)TC63/750	63 dBA

