

(S)TH6

Closed impellers

50 Hz

STH603...632

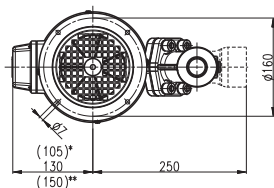
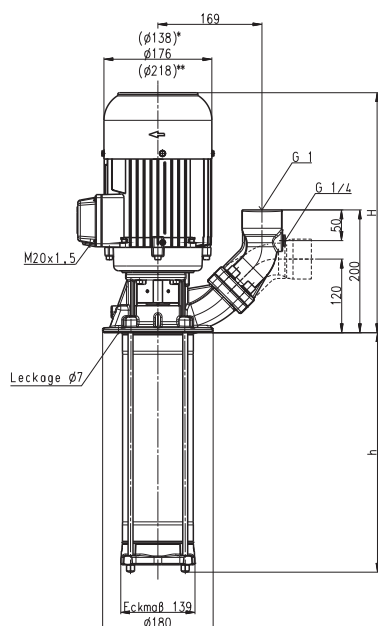

TH603...632

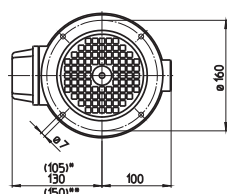
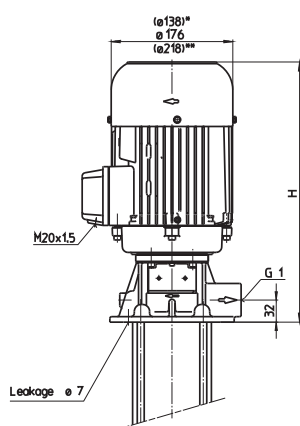

*) Dimensions for (S)TH603...(S)TH607
 **) Dimensions for (S)TH619...(S)TH632

Type	Vol. del. at manom. del. head l/min / m	Height H mm	Depth of immersion h mm	Weight kg	Power kW	Voltage 3 ~ V	Fre-quency Hz	Current A	Speed 1/min
(S)TH603A190	80/18	291	190	15.3	0.48	220-240 380-415	50 50	2.06 1.19	2820 2820
(S)TH604A190	80/24	332	190	16.8	0.63	220-240 380-415	50 50	2.70 1.56	2850 2850
(S)TH605A240	80/30	332	240	17.8	0.75	220-240 380-415	50 50	3.24 1.87	2850 2850
(S)TH606A240	80/36	332	240	18	0.92	220-240 380-415	50 50	3.8 2.2	2840 2840
(S)TH607A290	80/41	359	290	19.5	1.1	220-240 380-415	50 50	4.33 2.50	2850 2850
(S)TH608A290	80/48	381	290	26.2	1.3	220-240 380-415	50 50	4.85 2.80	2900 2900
(S)TH609A340	80/56	381	340	26.8	1.5	220-240 380-415	50 50	5.5 3.2	2880 2880
(S)TH610A340	80/61			27.0					
(S)TH611A390	80/71	407	390	29.5	1.7	220-240 380-415	50 50	6.24 3.60	2890 2890
(S)TH612A390	80/76	439	390	34	1.9	220-240 380-415	50 50	6.84 3.95	2900 2900
(S)TH613A490	80/82	439	490	35.0	2.2	220-240 380-415	50 50	7.8 4.5	2890 2890
(S)TH614A490	80/90			35.2					
(S)TH615A490	80/96			35.5					
(S)TH616A490	80/101	439	490	36.3	2.6	220-240 380-415	50 50	9.30 5.35	2880 2880
(S)TH617A590	80/108		590	36.8					
(S)TH618A590	80/114			37.0					
(S)TH619A590	80/120	432	590	48.3	3.3	220-240 380-415	50 50	11.6 6.7	2930 2930
(S)TH620A590	80/128			48.5					
(S)TH621A690	80/136		690	49.5					
(S)TH622A690	80/142	432	690	50.1	4.0	220-240 380-415	50 50	14.50 8.35	2920 2920
(S)TH623A690	80/150			50.3					
(S)TH624A690	80/155			50.5					
(S)TH625A790	80/160		790	51.2					
(S)TH626A790	80/166			51.4					
(S)TH627A790	80/172	462	790	58.8	5.0	220-240 380-415	50 50	17.3 10.0	2920 2920
(S)TH628A790	80/180			59.0					
(S)TH629A890	80/186		890	60.0					
(S)TH630A890	80/192			60.2					
(S)TH631A890	80/200			60.4					
(S)TH632A890	80/206			60.6					

Immersion Pumps

series TH and FH use **closed impellers** in order to minimize power consumption and to optimize hydraulic pump efficiencies.

In addition, the TH series offers high pressures at short immersion depths. Inline pumps of the series FH can be used as **boosting pumps** if provided with positive inlet pressure. This inlet pressure can be provided by the central coolant supply or a feed pump. In such a setup, pumps of the series FH can raise the incoming pressure by up to 26 bar.

Extended length is possible. See medium pressure pumps features within the technical information section.

Applications

- Types of fluid
 - Industry water
 - coolants
 - cooling/cutting oils
- Kinematic viscosity
 - 1 mm²/s (1 cSt)
 - higher viscosity upon request
- Pumping temperature
 - 0...80° C

Construction

Pump body	cast iron
Cover	cast iron
Impellers	CrNi-steel
Shaft	CrNi-steel
Diffusers	CrNi-steel
Mechanical seal	SiC
O-rings	Viton
Optional:	
Pump body	bronze
Cover	bronze
	CrNi-steel
Noise level	
(S)TH603...(S)TH607	58 dBA
(S)TH608...(S)TH618	63 dBA
(S)TH619...(S)TH632	71 dBA

