

STH21

Closed impellers

50 Hz

STH21

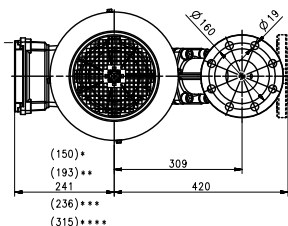
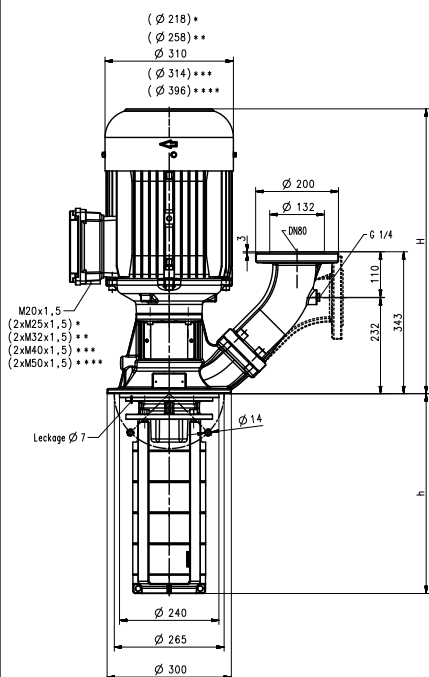

- *) Dimensions for 3 kW...6 kW
- **) Dimensions for 7.5 kW...10.3 kW
- *) Dimensions for 11 kW
- **) Dimensions for 15 kW...25.3 kW
- **) Dimensions up to 30 kW

Type	Vol. del. at manom. del. head l/min / m	Height H mm	Depth of immersion h mm	Weight kg	Power kW	Voltage 3~ V	Fre- quen- cy Hz	Current A	Speed 1/min
STH2101-1A260	600/17	571	257	81	3.0	220-240	50	10.7	2930
						380-415	50	6.2	2930
STH2101-0A260	600/21	571	257	82	4.0	220-240	50	14.50	2920
						380-415	50	8.35	2920
STH2102-2A340	600/35	601	332	90	5.5	220-240	50	18.9	2915
						380-415	50	10.9	2915
STH2102-0A340	600/45	680	332	120	7.5	380-415	50	14.3	2950
STH2103-2A410	600/60	688	407	151	11.0	380-415	50	20.1	2960
STH2103-0A410	600/68								
STH2104-2A490	600/83	982	482	170	15.0	400	50	27	2960
STH2104-0A490	600/92								
STH2105-2A560	600/107	1042	557	182	18.5	400	50	32	2955
STH2105-0A560	600/115								
STH2106-2A640	600/130	1046	632	196	22.0	400	50	37.5	2950
STH2106-0A640	600/139								
STH2107-2A710	600/155	1125	707	305	30.0	400	50	53	2960
STH2107-0A710	600/162								
STH2108-2A790	600/177		782	307					
STH2108-0A790	600/186								
STH2109-3A860	600/197		857	310					

Immersion Pumps

series STH use **closed impellers** in order to minimize power consumption and to optimize hydraulic pump efficiencies. The STH series offers high pressures at short immersion depths. A **frequency converter** can be supplied for **special applications** or for matching the pump characteristic to a specific duty point. See page "Control/Regulation" in the Technical Information section of this catalog for further information.

Extended lengths are available. See medium pressure pumps features within the technical information section.

Applications

Types of fluid
 coolants
 cooling/cutting oils
 Kinematic viscosity
 ...45 mm²/s (45 cSt)
 Pumping temperature
 0...90° C

Construction

Pump body	cast iron
Cover	cast iron
Impellers	CrNi-steel
Shaft	CrNi-steel
Diffusers	CrNi-steel
Mechanical seal	SiC
O-rings	Viton

Noise level

STH2101-1A...STH2102-2A	71 dBA
STH2102-0A...STH2103-0A	74 dBA
STH2104-2A...STH2109-3A	78 dBA

